



Pull Type Fertilizer Spreader

BG800



Operator's Manual

Rel. 11/24

Page left blank intentionally

TO THE DEALER:

Assembly and proper installation of this product is the responsibility of the Tar River dealer. Read manual instructions and safety rules. Make sure all items on the Dealer's Pre-Delivery and Delivery Check Lists in the Owner's/Operator's Manual are completed before releasing equipment to the owner.

TO THE OWNER:

Read this manual before operating your Tar River equipment. The information presented will prepare you to do a better and safer job. Keep this manual handy for ready reference. Require all operators to read this manual carefully and become acquainted with all the adjustment and operating procedures before attempting to operate. Replacement manuals can be obtained from your selling dealer. The equipment you have purchased has been carefully engineered and manufactured to provide dependable and satisfactory use. Like all mechanical products, it will require cleaning and upkeep. Lubricate the unit as specified. Observe all safety information in this manual and safety decals on the equipment. For service, your authorized Tar River dealer has trained mechanics, genuine Tar River service parts, and the necessary tools and equipment to handle all your needs. Use only genuine Tar River service parts. Substitute parts will void the warranty and may not meet standards required for safe and satisfactory operation.

Record your implement model and serial number in the space provide below. Your dealer will need this information to give you prompt, efficient service.

Model Number: _____

Serial Number: _____

Date Purchased: _____

Table of Contents

Introduction	5
Technical Specifications	5
Safety	6
Safety Signal Words	6
General Safety Guidelines	7
Safety Decal Care	7
Before Operation	8
During Operation	9
Highway And Transport Operations	10-11
Operating Instructions.....	12-14
Lubrication and Maintenance.....	15-16
Torque Specifications	17
Parts Breakdown	19-25
Warranty	26

Technical Specifications

Thank you for purchasing your Tar River Fertilizer Spreader. The BG800 is a ground driven fertilizer spreader with steel gears engineered for everyday use. The adjustable tow bar allows the spreader to be used on multiple hitch height configurations. High floatation tires on a wide base gives greater stability over many types of terrain.

Technical Specifications

- Gearbox is equipped with steel gears
- Adjustable towing hitch
- High floatation tires
- Powder coated frame and hopper or Poly hopper
- Left - center - right spread pattern

Model:	BG800
Weight	416 lbs.
Capacity (lbs.)	1,885 lbs.
Capacity (cu. ft.)	27.5 lbs.
Spread swath	52'
Hopper	Steel
Hopper height	34"
Tires	20" x 10" x 8"

Important Safety Information

Safety

It is important that you read the entire manual and to become familiar with this product before you begin using it. This product is designed for certain applications only. The manufacturer cannot be responsible for issues arising from modification. We strongly recommend this product not be modified and /or used for any application other than that for which it is designed. If you have any questions relative to a particular application, DO NOT use the product until you have first contacted us to determine if it can or should be performed on the product.

Read and understand this manual and all safety signs before operating and maintaining . Review the safety instructions and precautions annually.

Safety Signal Words

TAKE NOTE! This safety alert symbol found though out this manual is used to call you attention to instructions involving you personal safety and the safety of others. Failure to follow these instructions can result in injury or death.



**This symbol means:
Attention!
Become alert!
Your safety is involved!**

Note the use of the signal words, **DANGER, WARNING and CAUTION** with the safety messages. The appropriate signal word for each has been selected using the following guidelines:



DANGER: Indicates an imminently hazardous situation that, if not avoided, will result in death or serious injury. This signal word is to be limited to the most extreme situations typically for machine components which, for functional purposes, cannot be guarded.



WARNING: Indicates a potentially hazardous situation that, if not avoided, could result in death or serious injury, and includes hazards that are exposed when guards are removed. It may also be used to alert against unsafe practices.



CAUTION: Indicates a potentially hazardous situation that, if not avoided, may result in minor or moderate injury. It may also be used to alert against unsafe practices.

Important Safety Information

General Safety Guidelines

Safety of the operator is one of the main concerns in designing and developing a new piece of equipment. Designers and manufacturers build in as many safety features as possible. However, every year many accidents occur which could have been avoided by a few seconds of thought and a more careful approach to handling equipment. You, the operator, can avoid many accidents by observing the following precautions in this section. To avoid personal injury, study the following precautions and insist those working with you, or for you, follow them.

Replace any **DANGER, WARNING, CAUTION** or instruction safety decal that is not readable or is missing. Location of such decals are indicated in this manual. Do not attempt to operate this equipment under the influence of drugs or alcohol.

Review the safety instructions with all users annually.

This equipment is dangerous to children and persons unfamiliar with its operation. The operator should be a responsible adult familiar with farm machinery and trained in this equipment's operations. **Do not allow persons to operate or assemble this unit until they have read this manual and have developed a thorough understanding of the safety precautions and of how it works.**

To prevent injury of death, use a tractor equipped with a Roll Over Protection System (ROPS). Do not paint over, remove or deface any signs or warning decals on your equipment. Observe all safety signs and practice the instructions on them.

Never exceed the limits of a piece of machinery. If its ability to do a job, or to do so safely, is in question - **Don't try it!**



Safety Decal Care

- Keep safety signs clean and legible at all times.
- Replace safety signs that are missing or have become illegible.
- Replaced parts that displayed a safety sign should also display the current safety sign
- Safety signs are available from your Distributor or Dealer Parts Department or the factory.

Important Safety Information

How to Install Safety Signs

- Be sure that the installation area is clean and dry.
- Decide on the exact position before you remove the backing paper.
- Remove the smallest portion of the split backing paper.
- Align the decal over the specified area and carefully press the small portion with the exposed sticky backing in place.
- Slowly peel back the remaining paper and carefully smooth the remaining portion of the decal in place.
- Small air pockets can be pierced with a straight pin and smoothed out using the piece of decal backing paper.



Before Operation

- Carefully study and understand this manual.
- Do not wear loose-fitting clothing, which may catch in moving parts.
- Always wear protective clothing and substantial shoes.
- Assure that all tires are inflated evenly.
- Give the machine a visual inspection for any loose bolts, worn parts or cracked welds, and make necessary repairs. Follow the maintenance safety instructions included with this manual.
- Be sure that there are no tools lying on or in the equipment.
- Do not use the machine until you are sure that the area is clear, especially of children and animals.
- Don't hurry the learning process or take the machine for granted. Ease into it and become familiar with your new equipment.
- Practice operation of your equipment and its attachments. Completely familiarize yourself and other operators with its operation before using.
- Use a tractor equipped with a Roll Over Protection System (ROPS) and fasten your seat belt prior to starting engine.
- The manufacturer does not recommend usage of tractor with ROPS removed.
- Move tractor wheels to the widest recommended settings to increase stability.
- Securely attach to towing unit. Use a high strength, appropriately sized hitch pin with a mechanical retainer and attach safety chain.
- Do not allow anyone to stand between the tongue or hitch and the towing vehicle when backing up to the equipment.

Important Safety Information



During Operation

- Children should not be allowed on the product.
- Clear the area of small children and bystanders before moving the machine.
- If using a towing unit, securely attach machine by using a hardened 3/4" pin, a metal retainer, and safety chains if required. Shift towing unit to a lower gear before going down steep downgrades, thus using the engine as a retarding force. Keep towing vehicle in gear at all times. Slow down for corners and rough terrain.
- Make sure you are in compliance with all local and state regulations regarding transporting equipment on public roads and highways. Lights and slow moving signs must be clean and visible by overtaking or oncoming traffic when machine is transported.
- Beware of bystanders, **particularly children!** Always look around to make sure that it is safe to start the engine of the towing vehicle or move the machine. This is particularly important with higher noise levels and quiet cabs, as you may not hear people shouting.
- **NO PASSENGERS ALLOWED!** Do not carry passengers anywhere on, or in, the tractor or equipment, except as required for operation.
- Keep hands and clothing clear of moving parts.
- Do not clean, lubricate or adjust your equipment while it is moving.
- When halting operation, even periodically, set the tractor or towing vehicle brakes, disengage the PTO, shut off the engine and **remove the ignition key.**
- Be especially observant of the operating area and terrain. Watch for holes, rocks or hidden hazards. Always inspect the area prior to operation.
- **DO NOT** operate near the edge of drop-offs or banks.
- **DO NOT** operate on steep slopes as overturns may result.
- Operate up and down (not across) intermediate slopes. Avoid sudden starts and stops.



Warning: Never backup with the machine on the ground! This will cause damage to the machine. Always lift the machine high enough to clear the ground before backing up.

Important Safety Information



Highway and Transport Operations

- Adopt safe driving practices.
- Keep the brake pedals latched together at all times. **Never use independent braking with machine in tow as loss of control and/or upset of machine can result.**
- Always drive at a safe speed relative to local conditions and ensure that your speed is low enough for an emergency stop to be safe and secure. Keep speed at a minimum.
- Reduce speed prior to turns to avoid the risk of overturning.
- Avoid sudden uphill turns on steep slopes.
- Always keep the tractor or towing vehicle in gear to provide engine braking when going downhill. Do not coast.
- Do not drink and drive!
- Comply with state and local laws governing highway safety and movement of farm machinery on public roads.
- Use approved accessory lighting flags and necessary warning devices to protect operators of other vehicles on the highway during daylight and nighttime transport. Various safety lights and devices are available from your dealer.
- The use of flashing amber lights is acceptable in most localities. However, some localities prohibit their use. Local laws should be checked for all highway and marking requirements.
- When driving the tractor and equipment on the road or highway under 40 kph (20 mph) at night or during the day, use the amber warning lights and a slow moving vehicle (SMV) identification emblem.
- Plan your route to avoid heavy traffic.
- Be a safe and courteous driver. Always yield to oncoming traffic in all situations, including narrow bridges, intersections, etc.
- Be observant of bridge loading ratings. Do not cross bridges rated at lower than the gross weight at which you are operating.
- Watch for obstructions overhead and to the side while transporting.
- Always operate in a position to provide maximum visibility at all times. Make allowances for increased length and weight of the equipment when making turns, stopping the machine, etc.
- Pick the most level route when transporting across fields. Avoid the edges of ditches or gullies and steep hillsides.
- Be extra careful when working in inclines.

Important Safety Information



Highway and Transport Operations

- Maneuver the tractor or towing vehicle at safe speeds.
- Avoid overhead wires or other obstacles. Contact with overhead lines could cause serious injury or death.
- Avoid loose fill, rocks and holes, they can be dangerous for equipment operation or movement.
- Allow for machine length when making turns,
- Operate the towing vehicle from the operator's seat only.
- Never stand alongside of machine with engine running or attempt to start engine and/or operate machine while standing alongside of machine.
- Never leave running equipment attachments unattended.
- As a precaution, always recheck the hardware on equipment following every 100 hours of operation. Correct all problems. Follow the maintenance safety procedures.

Operating Instructions



Warning: When attaching the machine, *Never* allow anyone to stand between the machine and the tractor. Serious injury or death can occur!

Attaching to a ATV, UTV or Tractor.

Slide the spreader hitch over the tractor drawbar and secure with a hitch pin and lynch pin, Fig. 1.

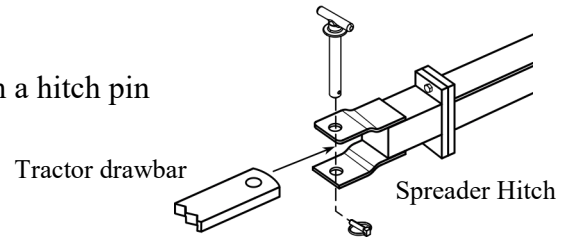

Fig. 1

Spreading Operation

It is important the spreader disc is horizontal to spread material uniformly and should be adjusted prior to adding material to the hopper. **NOTE: NEVER adjust the machine level with material in the hopper! A hopper with any amount of material can be extremely heavy. Serious injury or death can occur!** It is recommended to have a helper assist in adjusting the spreader disc level.

To adjust spreading disc level:

1. Remove the hardware attaching the arms to the hitch (2a) as shown in Figure 2. Loosen the hardware attaching the arms to the spreader frame (2b). It is not necessary to remove this hardware.
2. Select the hole in the Level Adjustment Plate that best levels the spreading disc.
3. Tighten all hardware to proper torque specs.

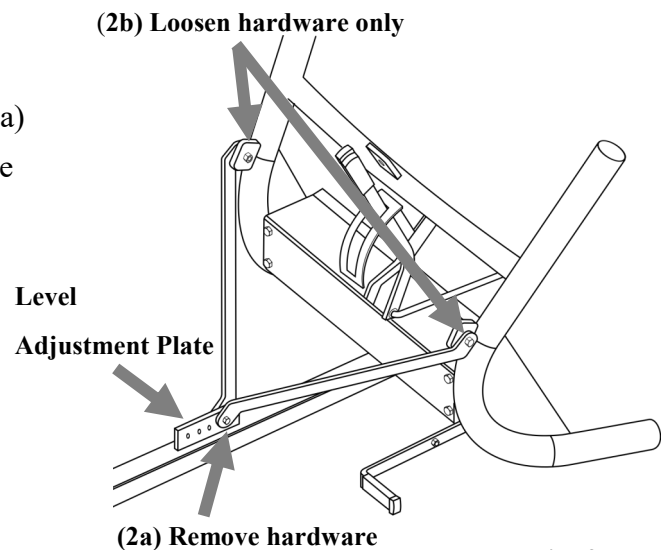

Fig. 2

Consider the following factors when determining material quantity distributed per acre:

1. Operating speed is determined by ground conditions. Faster speeds can be obtained on dry, level, cleared land. Slower speeds are required for uneven ground. Making a practice run will help determine the correct setting for spreading as conditions vary.
2. Type or material distributed, density, moisture content, etc.
3. Width of spreading area.
4. Spreader lever position.

Operating Instructions

Spreading with revolving vanes.

Since fertilizers vary with respect to weights and density; in order to obtain a perfect spread pattern, it may be necessary to adjust the vanes in order to compensate for these differences. The vanes are usually set to the center position.

Spread pattern can be regulated by adjusting the Spreader Wings located on the Spreader Disc, (See Fig. 3) Loosen the bolt "A" (do not remove) and remove Bolt "B". Rotate the Spreader Wings **Clockwise** to spread material more to the left. Rotate Spreader Wings **Counter-Clockwise** to spread material more to the right. Be sure to tighten hardware to proper torque settings.

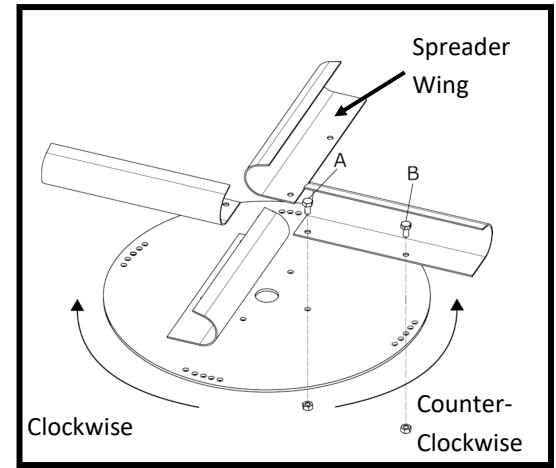

Fig. 3

Left– Center – Right Spreader pattern

A simple adjustment of the lower lever allows direction of the spreader pattern towards the right, center or left of the tractor. See Fig. 4.

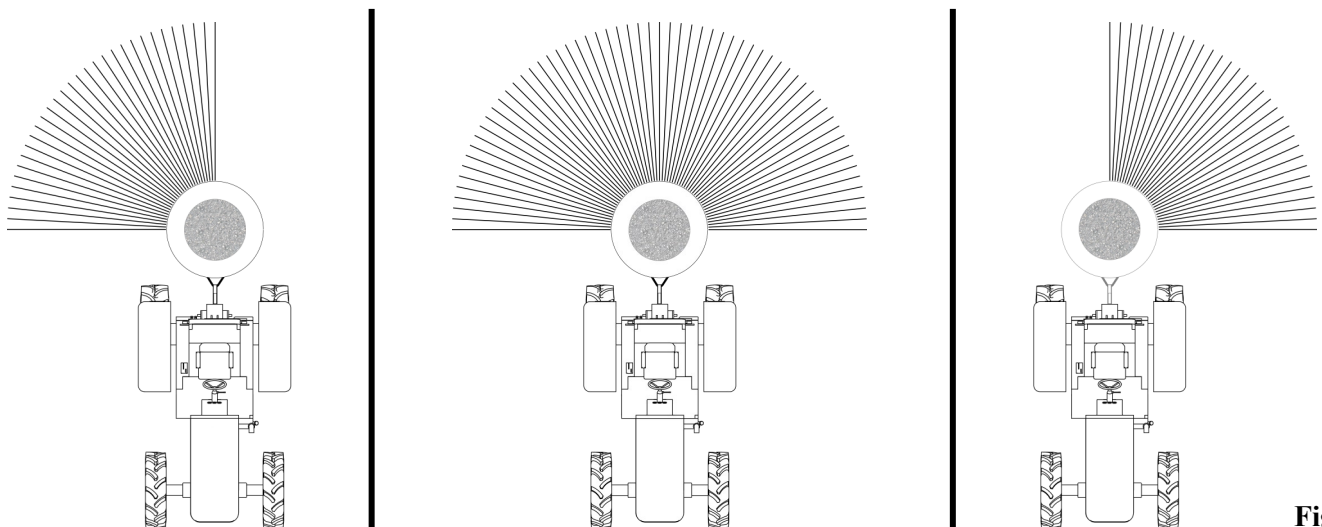

Fig. 4

Operating Instructions

Spreading Width.

Spreading width is directly affected by ground speed. The faster the ground speed, the further material will be spread (See Fig. 5). An optional Deflector shield (Part Number PTS-001) is available to further control spreading distance. Moving the Deflector Shield up increases the spreading distance. Moving the Deflector Shield down will decrease the spreading distance.

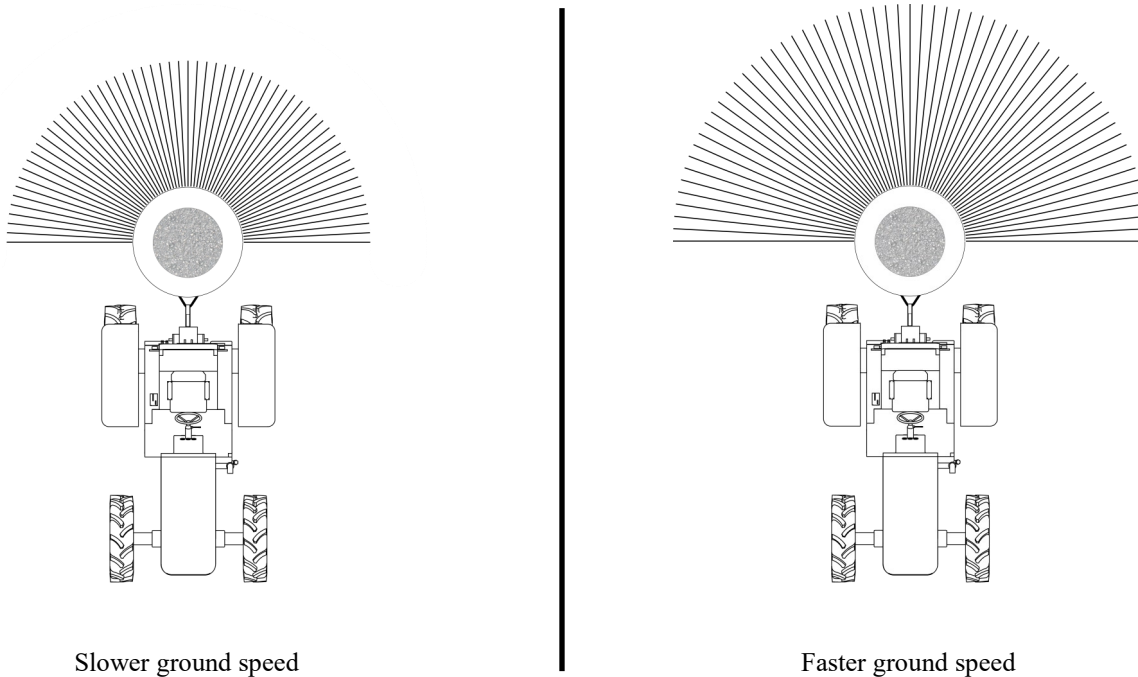

Fig. 5



Caution: There is a possibility of roll-over when operating tractor and spreader over uneven ground.

Operating on uneven ground.

Take the following precautions when operating on uneven ground:

1. If the terrain is extremely uneven, use tractor rear wheel weights, front tractor wheel weights, and or tire ballast to improve stability.
2. Consider the work area conditions to determine the best and safest procedure for spreading.
3. If there is a question of traction or stability issues, make a test run over the terrain.
4. Only operate the tractor and spreader up and down inclines, never across. Driving across an incline only increases the possibility of tip over.
5. When encountering a deep or sharp dip, drive across diagonally to prevent tractor or spreader from dragging the ground possibly causing damage to the spreader.
6. Slow the tractor when making sharp turns to prevent tipping over or losing control of the tractor.
7. Be observant of land conditions, holes, ditches, rocks, roots and other hidden objects. Do not operate near ditch banks, stream banks or gully edge.

Lubrication & Maintenance



Danger: Never attempt to perform maintenance on the machine without first stopping the towing vehicle's engine, setting the parking brake and removing the key from the ignition. Always wear the proper protection (PPE) when performing service. Refer to the chemical manufacturer for proper safety recommendations.

- Proper maintenance is the responsibility of the owner/operator. Poor maintenance is an invitation to trouble.
- Operate the spreader in an area with adequate ventilation. Never operate the engine of the towing vehicle in a closed building. Exhaust fumes may cause asphyxiation (suffocation) leading to serious injury or death.
- Be certain all moving parts on attachments have come to a complete stop before attempting to perform maintenance.
- Always use the proper tools or equipment for the job at hand. Maintenance area should be clean and dry. Electrical outlets and tools are to be properly grounded.
- Use extreme caution when making adjustments. Securely block equipment before servicing.
- After servicing, be sure all tools, parts and service equipment are removed.
- Use personal protection equipment (PPE) such as eye, hand, hearing and proper mask to filter any chemicals used.
- Check tightness of all hardware periodically, including; bolts, nuts, screws, pins. See page "Torque Specification" Chart in page 21 for proper torque specifications.
- Inspect tires for damage, wear and tear, and pressure. Add the proper amount of air according to the tire manufacturers specifications. Pressure specifications can be found on the tire.
- Use caution when inflating or servicing tires. Tires can be extremely dangerous if mishandled. Call on trained professions to service the tires if necessary.
- Where replacement parts are necessary for periodic maintenance and servicing, genuine factory replacement parts must be used to restore your equipment to original specifications. The manufacturer will not claim responsibility for use of unapproved parts and/or accessories and other damages as a result of their use.
- If equipment has been altered in any way from original design, the manufacturer does not accept any liability for injury or warranty.

Service

Before operating spreader:

- Grease all exposed moving parts.
- Check air pressure in tires.
- Check all hardware for tightness.
- Replace worn or damaged parts.

Lubrication & Maintenance

After operating spreader:

- Wash the spreader thoroughly. This is extremely important especially after spreading corrosive materials such as fertilizer or salt. These materials are highly corrosive and will eat away at metal parts.
- Dry the machine after washing to remove any remaining water. Moisture will cause rust to form and corrode metal parts.
- Exposed parts should be coated with a thick layer of grease for lubrication and protection.

End of season or prolonged storage:

- Spreader should be washed and dried thoroughly.
- Examine the spreader for any damaged or worn parts. Replace only with OEM parts to prevent voiding warranty.
- Check for corrosion on painted parts. It is advisable to remove any loose rust, prime and paint these parts to avoid further corrosion.
- All exposed moving parts should be coated with grease.
- Store the spreader in a clean and dry location. If shelter is not possible, the spreader should be covered from the elements.

Torque Specifications

Torque Specifications for Common Bolt Sizes															
Inches		Bolt Head Identification						Metric		Bolt Head Identification					
										5.8		8.8		10.9	
Bolt size (inches)	Thread pitch	Grade 2		Grade 5		Grade 8		Class 5.8		Class 8.8		Class 10.9			
		N.m	ft-lb	N.m	ft-lb	N.m	ft-lb	N.m	ft-lb	N.m	ft-lb	N.m	ft-lb		
1/4"	20	7	5	11	8	16	12	M5	0.08	4	3	6	4	9	7
1/4"	28	8	6	13	10	19	14	M6	1	6	4	10	7	15	11
5/16"	18	15	11	24	17	33	25	M8	1.25	16	12	25	18	36	27
5/16"	24	17	13	26	19	37	27	M8	1	17	13	26	19	38	28
3/8"	16	27	20	42	31	59	44	M10	1.5	31	23	48	35	71	52
3/8"	24	31	23	47	35	67	49	M10	1.25	33	24	51	38	75	55
7/16"	14	43	32	67	49	95	70	M10	1	35	26	53	39	78	58
7/16"	20	48	36	75	55	106	78	M12	1.75	54	40	84	62	123	91
1/2"	13	66	48	102	75	144	106	M12	1.5	56	41	87	64	128	94
1/2"	20	75	55	115	85	163	120	M12	1.25	59	44	90	66	133	98
9/16"	12	95	70	147	109	208	154	M14	2	84	62	133	98	195	144
9/16"	18	106	79	164	121	232	171	M14	1.5	94	69	142	105	209	154
5/8"	11	132	97	203	150	287	212	M16	2	131	97	206	152	302	223
5/8"	18	149	110	230	170	325	240	M16	1.5	141	104	218	161	320	236
3/4"	10	233	172	361	266	509	376	M18	2.5	181	133	295	218	421	310
3/4"	16	261	192	403	297	569	420	M18	2	196	145	311	229	443	327
7/8"	9	226	167	582	430	822	606	M18	1.5	203	150	327	241	465	343
7/8"	14	249	184	642	473	906	668	M20	2.5	256	189	415	306	592	437
1"	8	339	250	873	644	1232	909	M20	1.5	288	212	454	335	646	476
1"	12	371	273	955	704	1348	995	M22	2.5	344	254	567	418	807	595
1-1/8"	7	480	354	1077	794	1746	1288	M22	1.5	381	281	613	452	873	644
1-1/8"	12	539	397	1208	891	1958	1445	M24	3	444	327	714	526	1017	750
1-1/4"	7	677	500	1519	1120	2463	1817	M24	2	488	360	769	567	1095	808
1-1/4"	12	750	553	1682	1241	2728	2012	M27	3	656	484	1050	774	1496	1103
1-3/8"	6	888	655	1992	1469	3230	2382	M27	2	719	530	1119	825	1594	1176
1-3/8"	12	1011	746	2268	1673	3677	2712	M30	3.5	906	668	1420	1047	2033	1499
1-1/2"	6	1179	869	2643	1949	4286	3161	M30	2	1000	738	1600	1180	2250	1659
1-1/2"	12	1326	978	2974	2194	4823	3557	M36	4	1534	1131	2482	1830	3535	2607

Notes:

This chart is an approximate estimate of torque values.

Always tighten hardware to these values unless a different torque value or tightening procedure is listed for a specific application.

Fasteners must always be replaced with the same grade as specified in the manual.

Always use the proper tool for tightening hardware: SAE for SAE hardware and Metric for Metric hardware.

Page left blank intentionally



Pull Type Fertilizer Spreader

BG800



Parts Manual

Rel. 11/24

BG800 Spreader Assembly

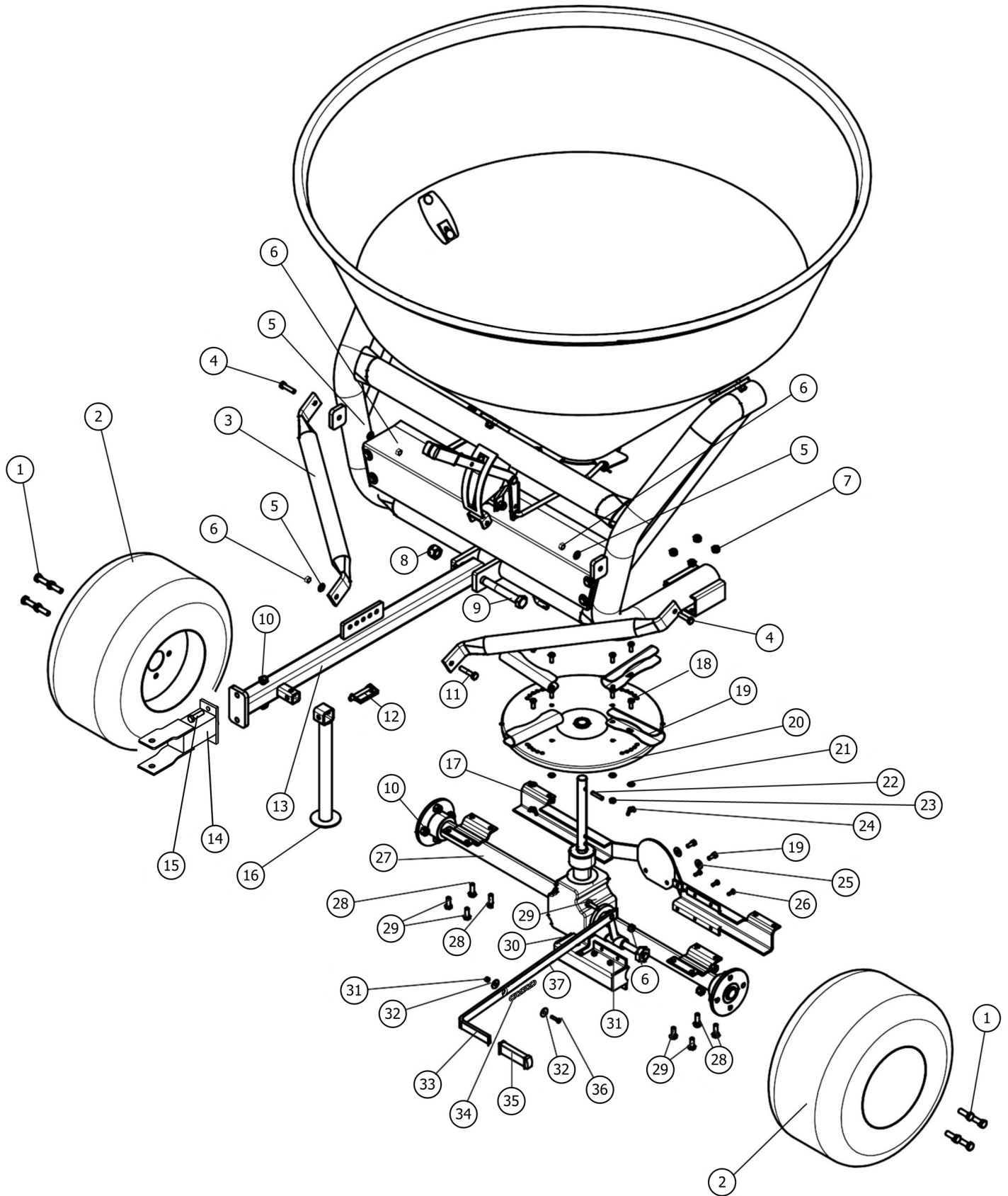

BG800 Spreader Assembly

Item	Part #	Description	Qty.
1	BM1217535FT	Bolt HH M12-1.75x35 8.8 Full Thread	8
2	FA10088	Wheel 20x10x8 4 ply – rim with 4 holes	2
3	FA10037	Tie rod BG800	2
4	BM101540FT	Bolt HH M10-1.5x40 8.8 Full Thread	2
5	FW10	Washer flat M10	4
6	NM1015	Nut M10-1.5	4
7	LNM1015	Nut HH self locking M10-1.5	8
8	LNM2025	Nut HH self locking M20-2.5	1
9	BM2025120	Bolt HH M20-2.5x120 8.8	1
10	LNM12175	Nut HH self locking M12-1.75	8
11	BM101550	Bolt HH M10-1.5x50 8.8	2
12	EP308-0210	Safety pin	1
13	FA10032	Beam BG800	1
14	FA10042	Hitch BG800	1
15	BM1217540FT	Bolt HH M12-1.75x40 8.8 Full Thread	2
16	FA10046	Stand BG800	1
17	FA10142	Axle reinforcement BG800	1
18	BM0812520FT	Bolt HH M08-1.25x20 8.8 Full Thread	8
19	FA10027	Stainless steel fan	4
20	FA10025	Stainless steel spreading disc	1
21	FW08	Washer flat M08	8
22	FA10026	Elastic pin 8x40 ZN UNI 6873	1
23	NM08125	Nut HH M08-1.25	1
24	FA10031	Wing nut M 8 ZN UNI 5448	4
25	LFW08	Washer large flat M08x24	2
26	BM0610FT	Bolt HH M06-1.0 8.8 Full Thread	6
27	FA10022	Gearbox BG800	1
28	BM101530FT	Bolt HH M10-1.5x30 8.8 Full Thread	4
29	BM101525FT	Bolt HH M10-1.5x25 8.8 Full Thread	4
30	FA10142	Axle housing BG800	1
31	LNM0610	Nut HH self locking M06-1.0	1
32	LFW06	Washer large flat M06x24	1
33	FA10048	Disengagement lever BG800	1
34	FA10053	Chain	1
35	SA10052	Handle, disengagement lever BG800	1
36	BM061025FT	Bolt HH M06-1.0x25 8.8 Full Thread	1
37	RC3	R clip M3.5	1

BG800 Spreader Assembly

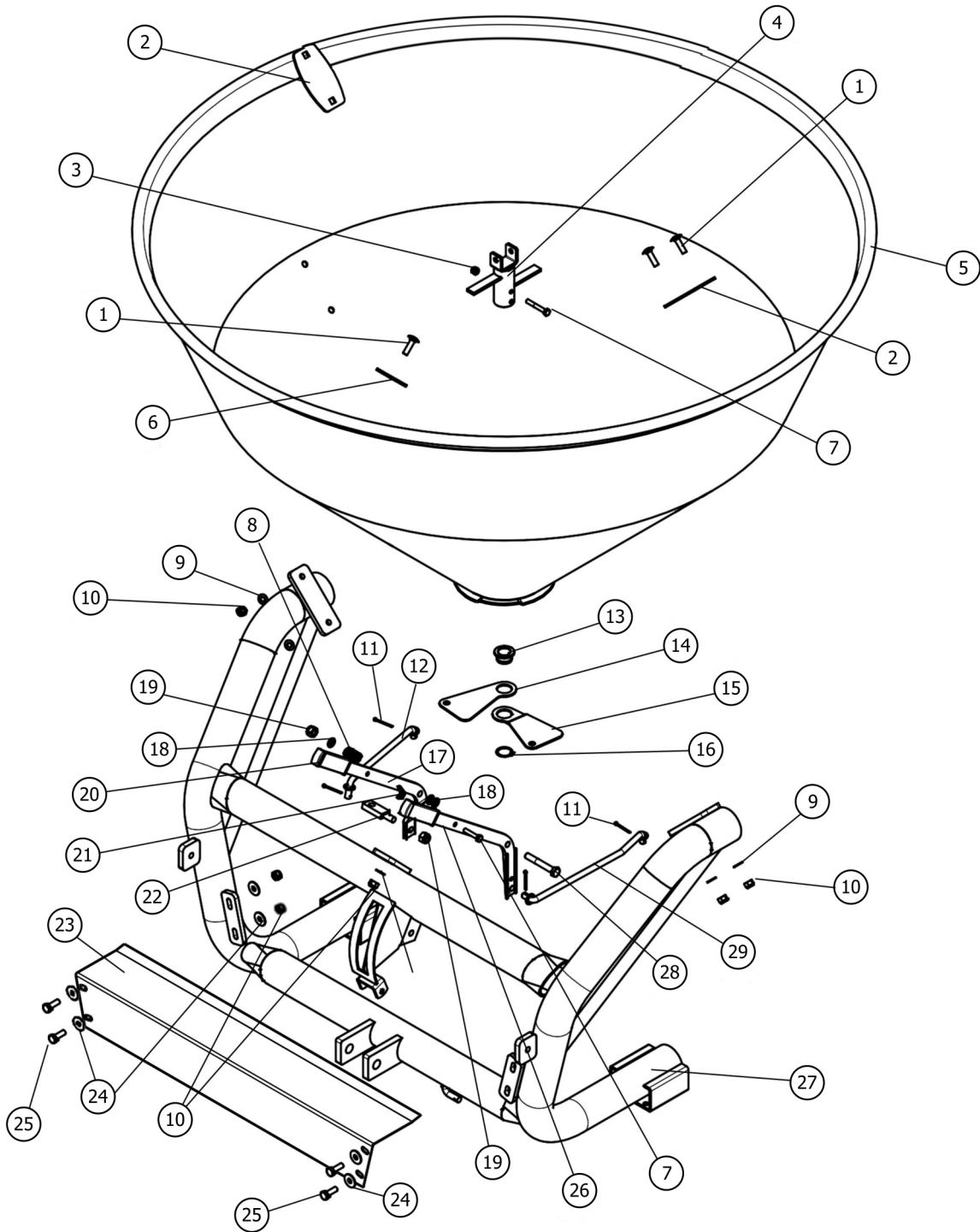

BG800 Spreader Assembly

Item	Part #	Description	Qty.
1	CBM101535	Bolt carriage M10-1.5x35	5
2	FA10143	Hopper side reinforcement plate	2
3	LNLM08125	Nut self locking M08-1.25	1
4	FA10073	Agitator BG800	1
5	FA10066	Hopper BG800	5
6	FA10144	Hopper reinforcement washer	1
7	BM0812555	Bolt HH M08-1.25x55	1
8	FA10020	Spring	1
9	FW10	Washer flat M10	4
10	LNLM1015	Nut self locking M10-1.5	4
11	FA10080	Split pin 3x35 ZN UNI 1336	2
12	FA10011	Connecting rod, LH	1
13	FA10018	Retainer bushing	1
14	FA10069	RH shutter	1
15	FA10068	LH Shutter	1
16	FA10145	Seeger D.30 ZN UNI 7435	1
17	FA10015	Lever, RH	1
18	FW12	Washer flat M12	1
19	LNLM12175	Nut self locking M12-1.75	1
20	FA10013	Handle	2
21	FA10019	Wing nut M08-1.25	1
22	FA10017	Lever return	1
23	FA10057	Guard BG800	1
24	LFW10	Washer large M10x30	4
25	BM101530	Bolt HH M10-1.5x30	4
26	FA10014	Long lever	1
27	FA10021	Frame BG800	1
28	BM1217580	Bolt HH M12-1.75x80	1
29	FA10012	Complete short tie rod	1

BG800 Optional Remote Gate Control - Cable

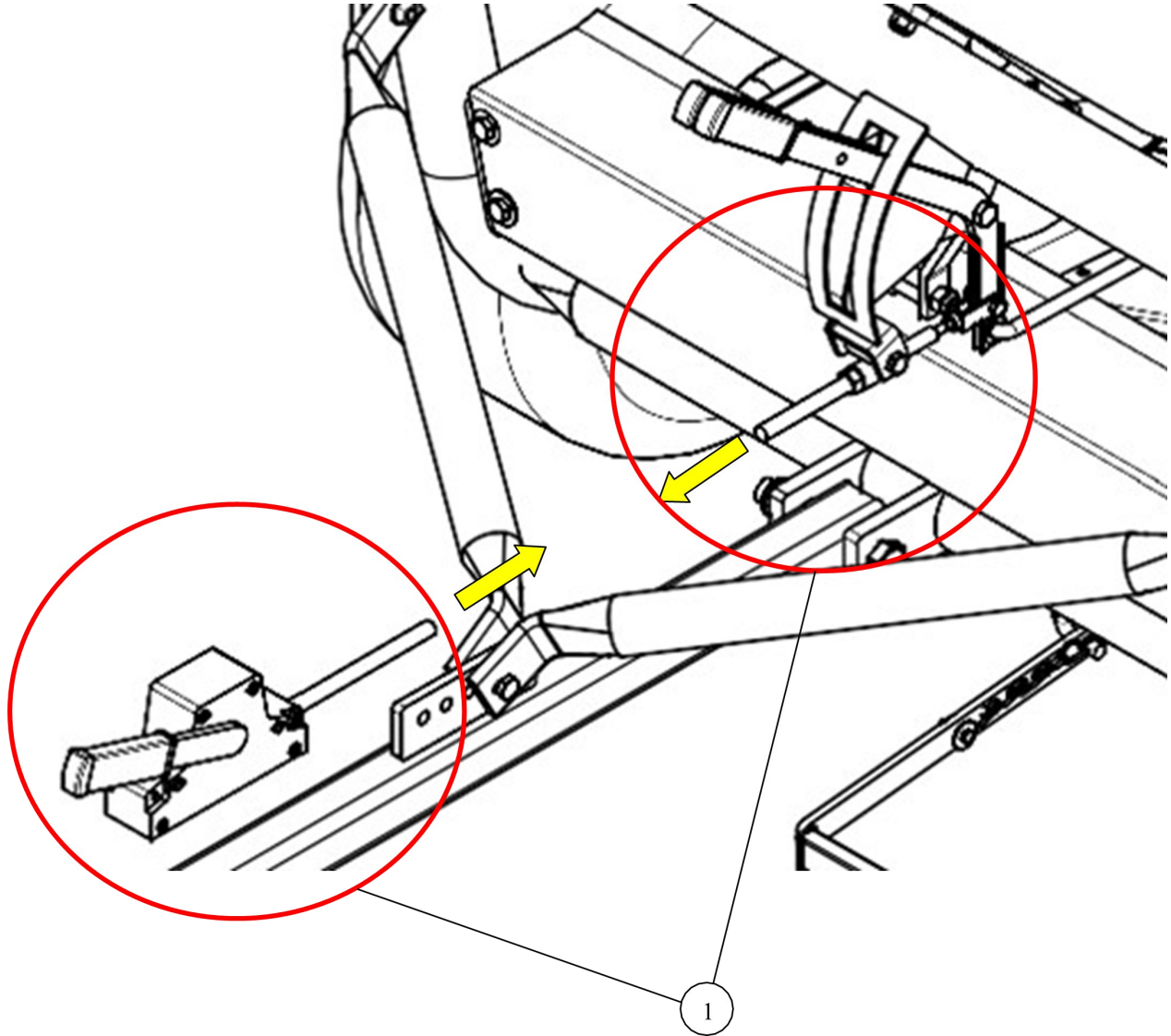

Item	Part #	Description	Qty.
1	FA10148	Mechanical remote control for opening TFS	1

BG800 Optional Remote Gate Control - Hydraulic

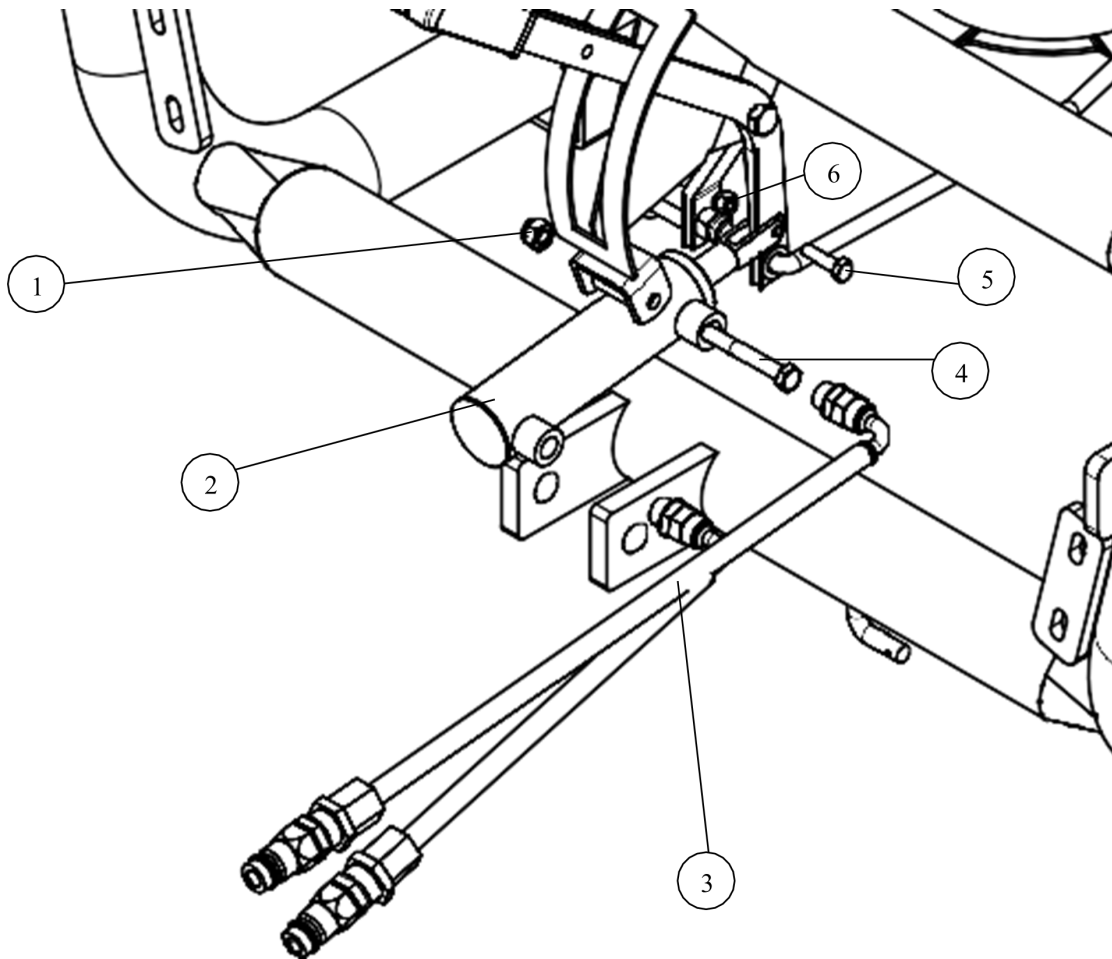

Item	Part #	Description	Qty.
1	LNМ1015	Nut HH self locking M10-1.5	1
2	FA10146	Opening cylinder	1
3	FA10147	Pipe L=2600 Tipe A	2
4	BM101570	Bolt HH M10-1.5x70 8.8	1
5	BM0812520FT	Bolt HH M08-1.25x30 8.8 Full Thread	1
6	LNМ08125	Nut HH self locking M08-1.25	1

Warranty

LIMITED WARRANTY

Belco Resources Equipment warrants to the original purchaser of any new piece of machinery from Belco Resources Equipment, purchased from an authorized Belco Resources Equipment dealer, that the equipment be free from defects in material and workmanship for a period of one (1) year for non-commercial, state, and municipalities' use, ninety (90) days for commercial use from date of retail sale. Warranty for rental purposes is thirty (30) days. The obligation of Belco Resources Equipment to the purchaser under this warranty is limited to the repair or replacement of defective parts.

Replacement or repair parts installed in the equipment covered by this limited warranty are warranted for ninety (90) days from the date of purchase of such part or to the expiration of the applicable new equipment warranty period, whichever occurs later. Warranted parts shall be provided at no cost to the user at an authorized Belco Resources Equipment dealer during regular working hours. Belco Resources Equipment reserves the right to inspect any equipment or parts, which are claimed to have been defective in material or workmanship.

This limited warranty does not apply to and excludes wear items such as shear pins, tires, tubes knives, blades or other wear items. Oil or grease is not covered by this warranty.

All obligations of Belco Resources Equipment under this limited warranty shall be terminated if:

- Proper service is not performed on the machine.

- The machine is modified or altered in any way.

- The machine is being used or has been used for purposes other than those for which the machine was intended.

DISCLAIMER OF IMPLIED WARRANTIES & CONSEQUENTIAL DAMAGES

Belco Resources Equipment obligation under this limited warranty, to the extent allowed by law, is in lieu of all warranties, implied or expressed, including implied warranties of merchantability and fitness for a particular purpose and any liability for incidental and consequential damages with respect to the sale or use of the items warranted. Such incidental and consequential damages shall include but not be limited to: transportation charges other than normal freight charges; cost of installation other than cost approved by Belco Resources Equipment; duty; taxes; charges for normal service or adjustment; loss of crops or any other loss of income; rental of substitute equipment, expenses due to loss, damage, detention or delay in the delivery.

REGISTRATION

The online Warranty Registration must be completed in order to qualify for coverage on this Limited Warranty. Visit br-equipment.com, click on "Warranty Registration" and completely fill out the form to register the new piece of equipment.

Page left blank intentionally



401 Jeffreys Road
Rocky Mount, NC 27804
www.tarrivermfg.com

Tel: 252-822-7140
Fax: 252-787-5855
Sales@tarrivermfg.com