

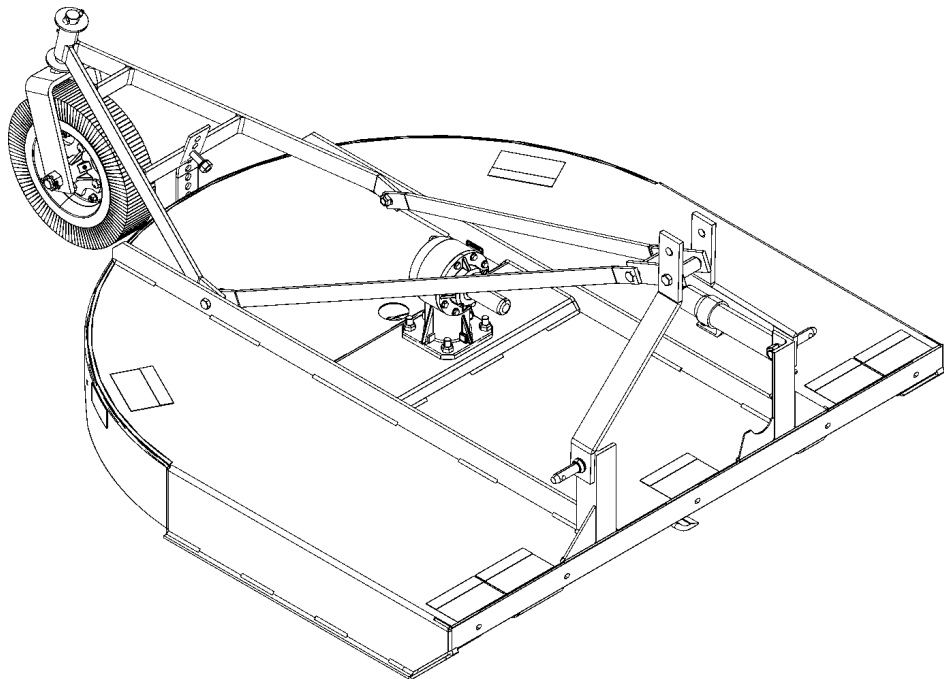

Standard Rotary Cutter

ARC148SP, ARC260SP, ARC260SC, ARC272SC



Operator's Manual

ARC4000834 / Revision A

Introduction

Thank you for purchasing the Standard Rotary Cutter. You can expect many years of reliable service when this implement is maintained and used within the limits of its capabilities. **READ THIS MANUAL CAREFULLY** to learn how to operate and service the implement correctly. Failure to do so could result in personal injury or equipment damage.

Intended Use

The Standard Rotary Cutter is designed to cut grass and light brush using a Category 1, 3-point hitch tractor. It is intended solely for the purposes outlined in this manual.

Using this Manual

This manual is designed to help familiarize the operator with the Standard Rotary Cutter's safety, assembly, operation, adjustments, troubleshooting, and maintenance expectations and create awareness of the hazards that operators may encounter because of its use. This manual intends to provide specific machine guidelines and help owners and operators obtain the best results and safe operation from their investment with a focus on accident and injury prevention.

All users must read and understand the information in this manual prior to operation. **DO NOT** allow anyone who has not fully read and understood this manual to operate or maintain the equipment. Failure to follow the procedures described in this manual could result in equipment damage or physical injury or death to you or bystanders.

Please keep this manual with the machine for future reference, as it is considered part of your machine. The lifespan of any machine depends on the care it receives. Refer to and review the manual often for preventative maintenance.

The information contained within this manual was current at the time of printing. Some parts or information are subject to change to ensure the best performance of the machine. The manufacturer reserves the right to make changes in materials or design of the product and its manual at any time without notice.

Throughout this manual, references are made to right and left directions. These are determined by standing behind the tractor and facing the direction of forward travel.

Owner Assistance

Use only genuine service parts available from an authorized dealer. Do not modify the implement or use with attachments other than the options and accessories specified in this manual.

Contact an authorized dealer if service or repair parts are needed. Authorized dealers have trained personnel, repair parts, and equipment needed to service this implement.

For quick reference and prompt service, record the model number and any other identifying information, such as a dealer-applied serial number or UPC, in the space provided below and again in the warranty section on **page 43**. These numbers will be needed when ordering service parts.

There may be times when circumstances not covered in the manual occur. At those times, or if this manual's instructions or safety requirements are not understood, please contact an authorized dealer.

Dealer Contact Information

Name

Address

Phone

Email

Purchase Date

Serial Number / UPC

Serial Label Location

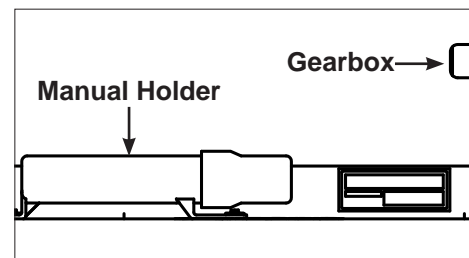

Serial number label located on left side backstrap weldment near manual holder.

Table of Contents

Introduction	i
Product Description	1
Safety Guidelines	2
Safety and Instructional Labels	8
Assembly and Setup.....	11
Install Shear Pin PTO.....	14
Install Slip Clutch PTO	15
Before Putting the Standard Rotary Cutter Into Service.....	16
Attaching to Tractor 3-Point Linkage	17
Detaching Standard Rotary Cutter from Tractor	17
Adjustments.....	18
Checking Driveline / Cutter Clearance	18
Sizing the PTO Shaft.....	19
Check Driveline Maximum Length.....	19
Check Driveline Maximum Angle.....	20
Operation.....	21
Accessories	23
Maintenance.....	29
Maintenance Schedule.....	29
Lubrication Schedule.....	30
Disassembling Driveline Shield	31
Removing and Installing Driveline Shear Bolt - Model ARC148SP, ARC260SP	32
Slip Clutch Operational Check - Model ARC260SC, ARC272SC.....	32
Disassembling and Inspecting Slip Clutch	33
Assembling Slip Clutch.....	33
Checking Blade Wear.....	33
Replacing Blades	33
Replacing Blade Pan.....	34
Storage	35
Troubleshooting.....	36
Product Specifications	37
Parts	39
Torque Specifications Chart.....	43
Warranty	45

Customer Support:

Phone: 1.252.822.7140

E-mail: sales@tarrivermfg.com

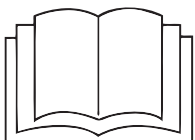

This Operator's Manual should be regarded as part of the machine. Suppliers of both new and second-hand machines must supply this manual with the machine. Replacement manuals are available from authorized dealers or Tar River Implements Customer Support.

PRODUCT DESCRIPTION

The Standard Rotary Cutter is intended for cutting grass and light brush up to 1" in diameter. It can be attached to a Category 1 tractor, and is perfect for creating trails, mowing fields, and clearing overgrown areas for wildlife. The 12-gauge welded steel deck features a 22.3" diameter, replaceable blade pan. The adjustable tailwheel offers a cutting height range of 1.5" up to 9" to accommodate various terrains.

Side View

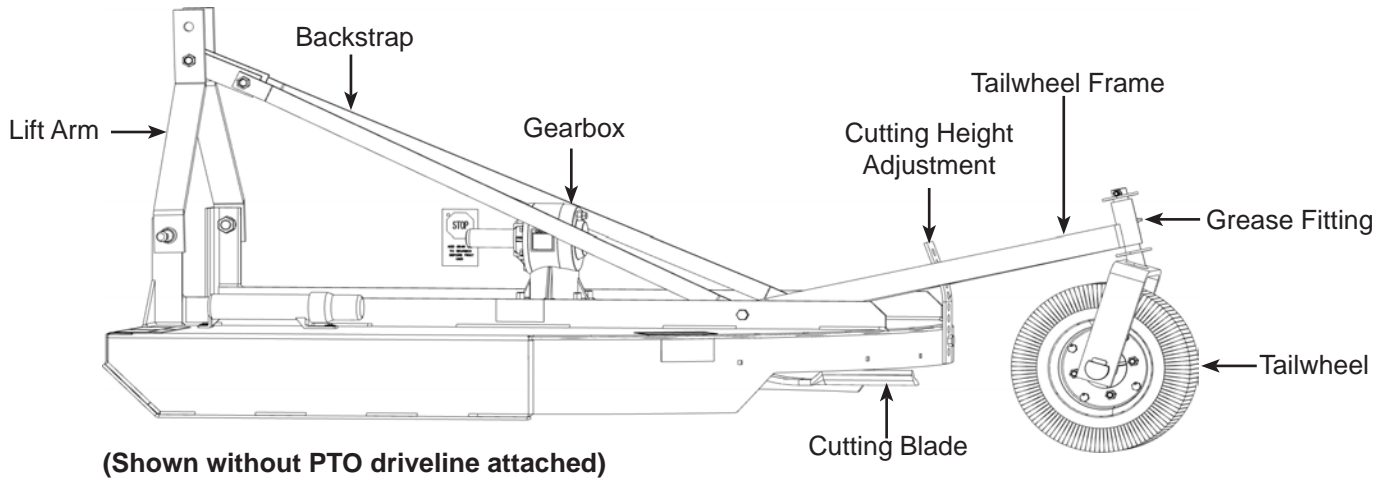

Top View

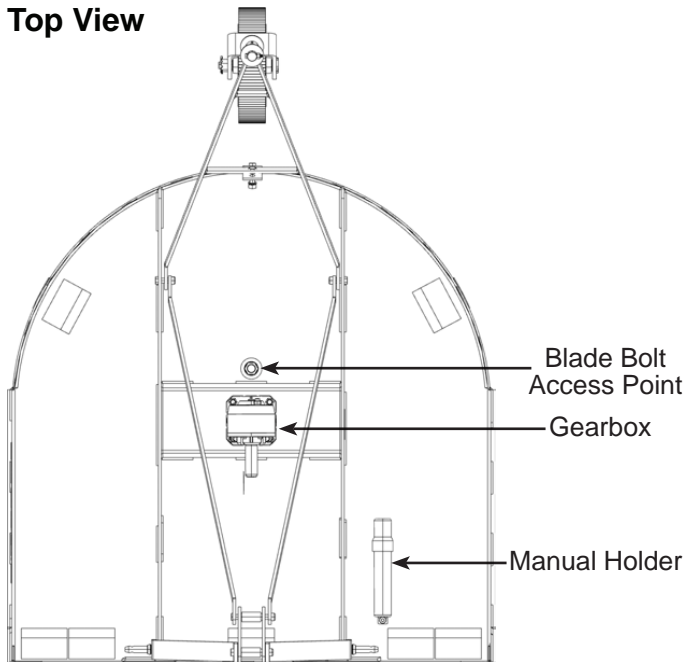

Bottom View

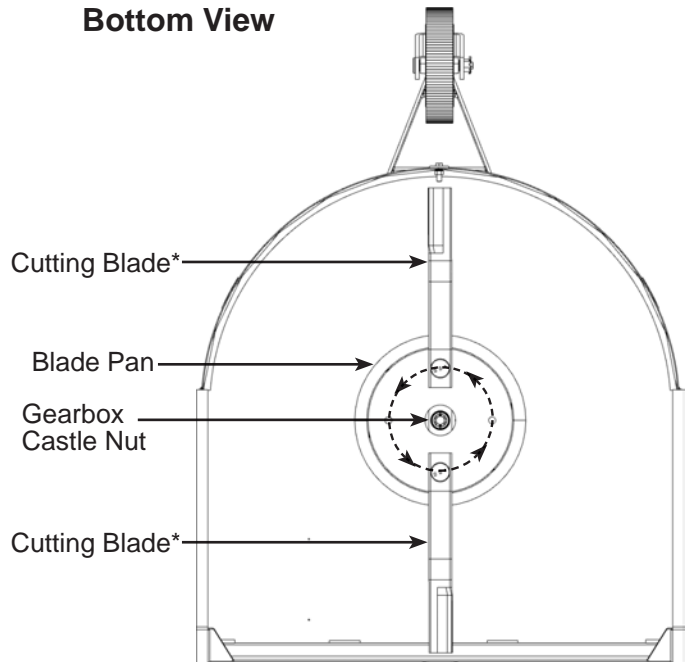

*Blades rotate counterclockwise.



IMPORTANT SAFETY MESSAGE FOR OWNERS/OPERATORS OF ROTARY CUTTERS

From members of the Farm Equipment Manufacturers Association

Rotary Cutter Manufacturer Product Council

Safety is a primary concern in the design, manufacture, sale, and use of rotary cutters. As manufacturers of rotary cutters, we want to confirm to you, our customers, our concern for safety. We also want to remind you about the simple, basic, and common sense rules of safety when using a rotary cutter. Failure to follow these rules can result in severe injury or death to operators or bystanders.

It is essential that everyone involved in the assembly, operation, transport, maintenance, and storage of this equipment be aware, concerned, prudent, and properly trained in safety. The majority of accidents involve entanglement on the driveline or thrown objects. These risks become greater when you do not use proper shielding specified by the manufacturer.

Our current production machines include, as standard equipment, guards or shields for drivelines and input shafts, safety signs and operators manuals. If you have an older machine which does not have current standard safety equipment, please contact your dealer about bringing your machine up to the current level of safety.

Below are some of the most important safety rules to be understood and followed by anyone who works with rotary cutters:

- Before operating a rotary cutter, an operator must read and understand all the information in the owner's manual and in the safety signs attached to the product. A person who has not read or understood the owner's manual and safety signs is not qualified to operate the cutter. Accidents occur often on machines that are loaned or rented to someone who has not read the owner's manual and is not familiar with a rotary cutter. If you do not have an owner's manual or current production safety signs, contact the manufacturer or your dealer immediately.
- Rotary cutters are designed for one-man operation. Never operate the cutter with anyone near, or in contact with, any part of the implement or PTO driveline. Be sure no one else, including bystanders, is near you when you operate this product.
- If operation of a rotary cutter around bystanders, animals, or property that may sustain damage (such as highway, park, or airport) is absolutely necessary, use safety guarding recommended by the manufacturer for thrown object prevention.

Following these simple, basic safety rules, as well as others identified in the owner's manual and in product safety signs, will help minimize the possibility of accidents and increase your productivity in using this product. Be careful and make sure that everyone who operates the cutter knows and understands that it is a very powerful piece of machinery, and if used improperly, serious injury or death may result. The final responsibility for safety rests with the operator of this machine.



A safety manual for Rotary Cutters is available through the FEMA office.

Phone: 314.878.2304

E-mail: staff@FarmEquip.org

SAFETY GUIDELINES

 **ATTENTION! BECOME ALERT! YOUR SAFETY IS INVOLVED!**

Safety is a primary concern in the design and manufacture of the Standard Rotary Cutter. Unfortunately, efforts to provide safe equipment can be wiped out by an operator's single careless act.

In addition to the design and configuration of equipment, hazard control and accident prevention are dependent upon the awareness, concern, judgment, and proper training of personnel involved in the operation, transport, maintenance, and storage of equipment.

Throughout this manual, the term **IMPORTANT** is used to indicate that failure to observe procedures can cause damage to equipment. The terms **DANGER**, **WARNING**, and **CAUTION** are used in conjunction with the Safety Alert Symbol, (a triangle with an exclamation mark), to indicate the degree of hazard for items of personal safety.

Safety Alert Symbol



This **SAFETY ALERT SYMBOL** identifies important safety messages on the equipment and in the operator's manual. When you see this symbol, be alert to the possibility of personal injury and carefully read the message that follows.

Safety Signal Words

The safety labels on the machine and safety messages in this manual use a combination of symbols, signal words, and color-coding to identify the following hazardous situations or safety practices:



DANGER

The signal word **DANGER** on the machine and in the manual indicates a hazardous situation which, if not avoided, will result in death or serious injury.



WARNING

The signal word **WARNING** on the machine and in the manual indicates a potentially hazardous situation which, if not avoided, could result in death or serious injury.



CAUTION

The signal word **CAUTION** on the machine and in the manual indicates a potentially hazardous situation which, if not avoided, may result in minor or moderate injury. It may also be used to alert against unsafe practices.

IMPORTANT

The signal word **IMPORTANT** identifies procedures which must be followed to avoid damage to the machine.

NOTE

Notes indicate important information. This information may be repeated in other areas of the manual.

CALIFORNIA

Proposition 65 Warning

Diesel engine exhaust and some of its constituents are known in the State of California to cause cancer, birth defects, and other reproductive harm.

For more information, visit: www.p65warning.ca.gov

SAFETY GUIDELINES

Training

Safety instructions are important! Read all attachments and power unit manuals; follow all safety rules and safety decal information. (Replacement manuals and safety decals are available from authorized Tar River Implements dealers.) Failure to follow instructions or safety rules can result in serious injury or death.

Operators needing assistance understanding any part of this manual should contact an authorized Tar River Implements dealer.

Operators must be instructed in and capable of operating the equipment, its attachments, and all controls safely. No one should operate the equipment without proper instructions. Operators must know how to stop the tractor engine and attached implement quickly in an emergency.

Never allow children or untrained persons to operate equipment.

Preparation

Check that all hardware is properly installed.

Always tighten to torque chart specifications unless instructed otherwise in this manual.

Always wear relatively tight and belted clothing to avoid getting caught in moving parts. Wear sturdy, rough-soled work shoes and protective equipment for eyes, hair, hands, ears, and head; wear respirator or filter mask where appropriate.

Make sure implement is properly secured, adjusted, and in good operating condition.

Make sure collar slides freely and is seated firmly in tractor PTO spline groove.

Before servicing equipment, check and adjust driveline length as instructed in Operator's Manual. Driveline must not bottom out or pull apart throughout the full range of the tractor hitch. **DO NOT** operate until driveline length is correct. Make sure driveline shield safety chain is attached as shown in this manual. Replace if damaged or broken.

Check that driveline guards rotate freely on driveline before servicing equipment.

Before starting power unit, check all equipment driveline guards for damage. Replace any damaged guards.

Make sure all guards rotate freely on all drivelines. If guards do not rotate freely on drivelines, repair and replace bearings before servicing equipment.

Inspect chain or rubber guards before each use. Replace if damaged.

Remove accumulated debris from this equipment, power unit, and engine to avoid fire hazard.

Power unit must be equipped with Roll-Over Protection System (ROPS) or ROPS cab and seat belt. Keep seat belt securely fastened. Falling off power unit can result in death from being run over or crushed. Keep foldable ROPS system in "locked up" position at all times.

A minimum of 20% of tractor and equipment weight must be on the tractor's front wheels when implements are in transport position. Without this weight, tractor could tip over, causing personal injury or death. The weight may be attained with a loader, front wheel weights, ballast in tires or front tractor weights. Weigh the tractor and equipment. **DO NOT ESTIMATE!**

Make sure all safety labels are installed. Replace if damaged. (See pp. 8-10, **SAFETY AND INSTRUCTIONAL LABELS** section for location.)

Make sure shields and guards are properly installed and in good condition. Replace if damaged.

Inspect and clear area of stones, branches, or other hard objects that might be thrown, causing injury or damage.

Starting and Stopping

Check the tractor master shield over the PTO (power take off) stub shaft. Make sure it is in good condition and fastened securely to the tractor. Purchase a new shield if old shield is damaged or missing.

All tractors that are not equipped with a "live" power take-off (PTO) must be equipped with an over-running PTO clutch. These are available through most farm equipment stores.

Note: Adding an over-running PTO clutch may change the required driveline length. Refer to the installation instructions—page 14 for shear pin models or page 15 for slip clutch models. Ensure adequate driveline guarding. Operating power is supplied by the tractor PTO; see the tractor manual for PTO engagement and disengagement instructions.

SAFETY GUIDELINES

Starting and Stopping Cont.

Understand how to stop tractor and implement quickly in case of an emergency.

When engaging the PTO, the engine RPM should always be at idle speed. Once engaged and ready to start, raise PTO speed to 540-RPM and maintain throughout operation.

Transportation

Power unit must be equipped with a Roll-Over Protection System (ROPS) or ROPS cab and seat belt. Keep seat belt securely fastened. Falling off power unit can result in death from being run over or crushed. Keep foldable ROPS system in "locked up" position at all times.

A minimum of 20% of tractor and equipment weight must be on the tractor's front wheels when implements are in transport position. Without this weight, tractor could tip over, causing personal injury or death. The weight may be attained with a loader, front wheel weights, ballast in tires or front tractor weights. Weigh the tractor and equipment. **DO NOT ESTIMATE!**

Always comply with all state and local lighting and marking requirements.

Never allow riders on power unit or implement.

DO NOT operate PTO during transport.

Watch for hidden hazards on the terrain.

DO NOT operate or transport on steep slopes.

DO NOT operate or transport equipment while under the influence of alcohol or drugs.

When encountering rough terrain during transport, reduce tractor speed to minimize the horizontal movement of implement.

Stabilizer bars should be used during transport to reduce lateral movement of implement.

DO NOT allow bystanders in the area when operating, attaching, removing, assembling, or servicing equipment.

Operation

Never discharge directly toward people, animals, or property.

Use both front and rear guards to reduce the possibility of object being thrown.

This implement is intended for agricultural applications only. **DO NOT** operate within 300 feet of bystanders or public roads or highways.

DO NOT operate or transport equipment while under the influence of alcohol or drugs.

Keep hands, feet, hair, and clothing away from equipment while engine is running. Stay clear of all moving parts.

Operate only in daylight or satisfactory artificial light.

Always comply with all state and local lighting and marking requirements.

Never allow riders on power unit or implement.

Operate tractor PTO at 540 RPM. **DO NOT exceed!**

Power unit must be equipped with a Roll-Over Protection System (ROPS) or ROPS cab and seat belt. Keep seat belt securely fastened. Falling off power unit can result in death from being run over or crushed. Keep foldable ROPS system in "locked up" position at all times.

Always sit in power unit seat when operating controls or starting engine. Securely fasten seat belt, place transmission in neutral, engage brake, and ensure all other controls are disengaged before starting power unit engine.

DO NOT operate PTO during transport.

Look down and to the rear and make sure area is clear before operating in reverse (operating in reverse is not recommended).

DO NOT operate or transport on steep slopes.

DO NOT stop, start, or change directions suddenly on slopes.

Use extreme care and reduce ground speed on slopes and rough terrain.

SAFETY GUIDELINES

Operation Cont.

Watch for hidden hazards on the terrain during operation. Stop power unit and equipment immediately upon striking an obstruction. Turn off engine, remove key, inspect, and repair any damage before resuming operation.

Leak down or failure of mechanical or hydraulic system can cause equipment to lower.

Maintenance

Before detaching power unit or performing any service or maintenance, follow these steps: disengage power to equipment, lower the 3-point hitch and all raised components to the ground, set parking brake, stop engine, remove key, and unfasten seat belt.

Before performing any service or maintenance, disconnect driveline from tractor PTO.

Before working underneath, carefully read Operator's Manual instructions, disconnect driveline, securely block up all corners, and check stability. Secure blocking prevents equipment from dropping due to hydraulic leak down, hydraulic system failures, or mechanical component failures.

DO NOT modify, alter, or permit anyone else to modify or alter the equipment or any of its components in any way.

Always wear relatively tight and belted clothing to avoid getting caught in moving parts. Wear sturdy, rough-soled work shoes and protective equipment for eyes, hair, hands, ears, and head; wear respirator or filter mask where appropriate.

Make sure implement is properly secured, adjusted, and in a safe operating condition.

Keep all persons away from operator control area while performing adjustments, service, or maintenance.

Never go underneath equipment (lowered to the ground or raised) unless it is properly blocked and secured. Never place any part of the body underneath equipment or between movable parts even when the engine has been turned off. Hydraulic system leak down, hydraulic system failures, mechanical failures, or movement of control levers can cause equipment to drop or rotate unexpectedly and cause severe injury or death. Follow Operator's Manual instructions for working underneath and blocking procedures.

Make certain all movement of equipment components has stopped before approaching for service.

Frequently check blades/tines/shanks. They should be sharp, free of nicks and cracks, and securely fastened.

DO NOT handle blades/tines/shanks with bare hands. Careless or improper handling may result in serious injury.

Storage

Block equipment securely for storage.

Keep children and bystanders away from storage area.

Follow operator's manual instructions for storage.

Always use a tractor to position equipment for storage. Never attempt to move equipment by hand.

Equipment Safety Guidelines

Safety of the operator and bystanders is one of the main concerns in design and development. However, accidents always occur which could have been avoided by a few seconds of thought and a more careful approach to handling equipment. Operators and others working with them can avoid many accidents by observing the following precautions.

In order to provide a better view, certain photographs or illustrations in this manual may show an assembly with a safety shield removed. However, equipment should never be operated in this condition. Keep all shields in place. If shield removal becomes necessary for repairs, replace the shield prior to use.

Replace any safety label that is illegible or missing. Location of such safety signs are indicated in this manual.

Never use alcoholic beverages or drugs that can hinder alertness or coordination while operating this equipment. Operators should consult their doctor about operating this machine while taking prescription medications.

Under no circumstances should children under the age of 18 be allowed to operate this equipment. DO NOT allow persons to operate or assemble this unit until they have read this manual and have developed a thorough understanding of the safety precautions and how it works. Review the safety instructions with all users annually.

SAFETY GUIDELINES

Equipment Safety Guidelines Cont.

This equipment can be dangerous to children and persons unfamiliar with its operation. The operator should be a responsible, properly trained and physically able person familiar with farm machinery and trained in this equipment's operations.

Use a tractor equipped with a Roll-Over Protection System (ROPS) and seat belts.

Never exceed the limits of a piece of machinery. If its ability to perform a job safely, is in question, **DON'T TRY IT.**

DO NOT modify the equipment in any way. Unauthorized modification could result in serious injury or death and may impair the function and life of the equipment.

In addition to the design and the confirmation of this implement, including safety labels and safety equipment, hazard control and accident prevention are dependent upon the awareness, concern, prudence, and proper training of personnel involved in the operation, transport, maintenance, and storage of the machine. Refer also to safety messages and operation instructions in each of the appropriate sections of the tractor and implement manuals. Heed the safety labels affixed to both the tractor and implement.

SAFETY AND INSTRUCTIONAL LABELS

! ATTENTION! BECOME ALERT! YOUR SAFETY IS INVOLVED!
Replace immediately if damaged!

The Standard Rotary Cutter comes equipped with all safety labels in place. These labels instruct the operator on the safe use of the equipment. They inform operators about hazards associated with normal operation or foreseeable product misuse and how to avoid them to prevent physical injury or death. All operators are required to read and follow directions on the safety labels.

Safety Label Guidelines

1. Keep all safety labels clean and legible.
2. Replace all damaged or missing labels.
3. New equipment installed during repairs may require replacement safety labels to be affixed to the replaced part, if missing.
4. Contact an authorized Tar River Implements dealer to order replacement labels.
5. Refer to Figure 1 and 2 for proper label placement. **NOTE:** All models have identical label placement locations.
6. When installing new labels:
 - a. Clean placement surface with soapy water or surface cleaning solution and allow to dry.
 - b. Peel backing from label, carefully center and place label in the correct location, ensuring no creases or air pockets.
 - c. Press label firmly onto the surface and use a straight edge to smooth the label on the machine for a secure adhesion.

Figure 1

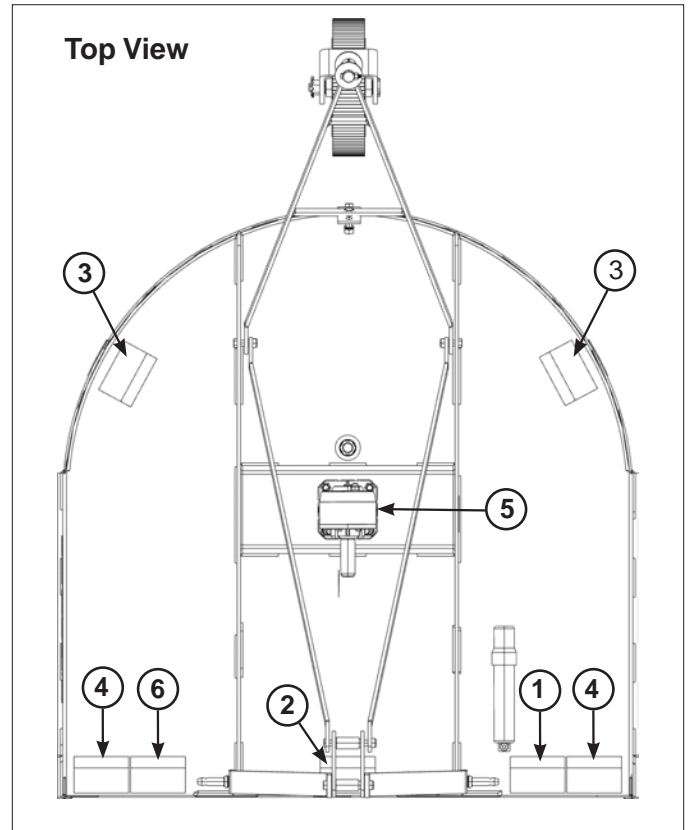
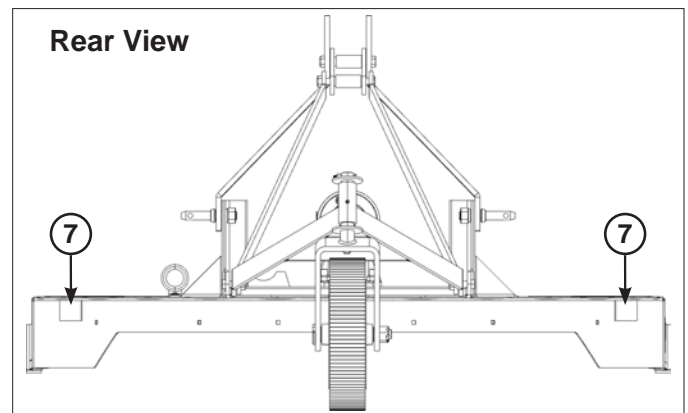

Figure 2



SAFETY AND INSTRUCTIONAL LABELS

⚠ ATTENTION! BECOME ALERT! YOUR SAFETY IS INVOLVED!
 Replace immediately if damaged!

⚠ WARNING

To prevent serious injury or death:

- Read and understand Operator's Manual before using. Review annually.
- Do not permit riders on the tractor or mower. Never carry children on tractor seat.
- Do not allow children to operate mower.
- Operate only with guards installed and in good condition.
- Keep away from moving parts.
- Operate only with tractor equipped with ROPS and seatbelts.
- Before mowing, clear debris from mowing area.
- Do not operate in the raised position.
- Stop engine, set brake and wait for all moving parts to stop before dismounting.
- Support mower securely before working beneath unit.
- Transport with clean reflectors, SMV and working lights as required by federal, state, and local laws.

ITEM 1

① SERIOUS INJURY

⚠ DANGER



**ROTATING DRIVELINE HAZARD
KEEP AWAY**

- Do not operate unless PTO guards, tractor master shield and implement guards are in place.
- PTO guards must turn freely and be properly attached and maintained.
- U-joint yokes must be securely locked onto tractor and implement shafts.
- Be sure tractor drawbar and implement hitch are adjusted correctly.
- Grease shaft regularly.
- This implement is designed to operate at 540 RPM maximum tractor PTO speed.
- Failure to heed these warnings may result in personal injury or death.

ITEM 2

② ROTATING DRIVELINE

⚠ DANGER



THROWN OBJECT HAZARD

To prevent serious injury or death:

- Do not operate unless all guards are installed and in good condition.
- Stop blade rotation if bystanders come within several hundred feet.

ITEM 3

(2 needed)

③ THROWN OBJECT

⚠ DANGER



ROTATING BLADES KEEP AWAY

To prevent serious injury or death when the engine is running and the blades are rotating:

- Never allow riders, especially children, on tractor or mower.
- Do not operate with bystanders in mowing area.
- Do not operate with deflectors/guards removed.
- Do not place hands or feet under deck.

ITEM 4

(2 needed)

④ ROTATING BLADES

SAFETY AND INSTRUCTIONAL LABELS

⚠ ATTENTION! BECOME ALERT! YOUR SAFETY IS INVOLVED!
Replace immediately if damaged!



⑤ NEEDS OIL

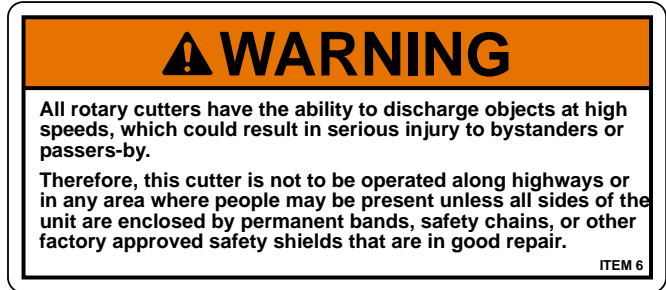

⑥ THROWN OBJECT



(2 needed)

⑦ RED REFLECTOR
Part ARCFT4003 (2" x 4 1/2")

ASSEMBLY AND SETUP

Assembly Information

The Standard Rotary Cutter ships securely attached to shipping stands. The lift arms and tailwheel must be transitioned to user position for the rotary cutter to operate as intended. An authorized Tar River Implements dealer may have already performed some or all of the assembly steps outlined on pages 11-16. All operators should review these instructions before attempting to use the rotary cutter to ensure that it is properly assembled.

Tools Needed:

- Pliers
- Ratchet
- Tin Snips
- Screwdriver
- Vice Grips
- Solid wood blocks or shop stands
- Sockets and Wrenches
(impact wrench preferred)
9/16", 3/4", 7/8", 15/16", 1 5/16", 7 mm

Recommended Personal Protective Equipment:

- Hard hat
- Safety glasses
- Work gloves
- Sturdy, rough-soled work shoes

Assembly Instructions

1. Cut the zip ties and remove the PTO Shaft from the backside of the rotary cutter.



2. Use a 9/16" wrench to remove the 3/8"-16 x 2" bolt and nut from the tailwheel holder on the shipping boot. **DO NOT DISCARD HARDWARE!**



3. Remove the tailwheel and 3" washer.



4. Place the rotary cutter on a level spot. Block up the front and back of the rotary cutter.



ASSEMBLY AND SETUP

Assembly Instructions Cont.

5. Install the tailwheel with 3" washer on top. Secure with 3/8" – 16 x 2" bolt and nut. Tighten.



6. Using 1-5/16" wrench/socket, remove the CAT 1 pins, hex nuts, flat washers, and spacer bushings from the shipping boots. Set hardware aside.

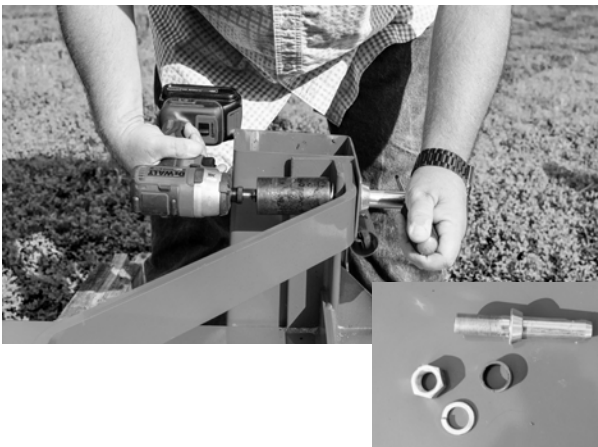

CAUTION

Avoid injury! Crushing Hazard!
Shipping boots may drop suddenly when CAT 1 pins are removed.

7. Once the CAT 1 pins are removed, lift up on the cutter to remove from the shipping boots.



8. Line up the holes on the A-frame and re-insert CAT 1 pins, bushing, washer and nut. Hand tighten only.

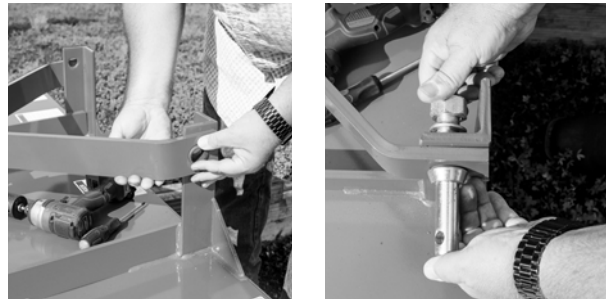

9. Remove the two zip ties from the tailwheel assembly and back braces.



10. Raise the lift arms in the upright position, using the bottom pivot point.



CAUTION

Avoid injury!
Watch for possible pinch points.

(Continued on next page.)

ASSEMBLY AND SETUP

Assembly Instructions Cont.

11. Remove nut on one side of the A-frame using 15/16" wrench.



12. Place the backstrap brace on the bolt, as pictured, using the locknut. Hand tighten. Repeat for other side.



13. Pull lift arms until they are into place.



14. Go back and tighten the CAT 1 pins, on both sides, using a 1-5/16" wrench/socket.



15. Tighten the nuts on the backstraps.



16. Remove the warning tag from gearbox.

IMPORTANT

Avoid Damage!

Add gear oil to gearbox before first use! Refer to BEFORE PUTTING THE STANDARD ROTARY CUTTER INTO SERVICE, p. 16.

17. Remove the shaft boot on the gearbox.



18. Remove the snap ring.



19. Install PTO Driveline.

- MODEL ARC148SP, ARC260SP:
Refer to INSTALL SHEAR PIN PTO, p. 14.
- MODEL ARC260SC, ARC272SC:
Refer to INSTALL SLIP CLUTCH PTO, p. 15.

ASSEMBLY AND SETUP

Install Shear Pin PTO: ARC148SP, ARC260SP

1. Slide the PTO shield back by using a screwdriver to apply pressure and release the locking collar. (There will be 3 tabs on the locking collar) Once the locking collar is released, slide the PTO shield back.



2. Remove the PTO shear bolt.



3. Slide the PTO shaft onto the gearbox shaft.



4. Replace the snap ring.



5. Align the shear bolt holes, install, and tighten the PTO shaft shear bolt.



6. **ASSEMBLY IS NOT COMPLETE!** Please read pp. 16-18, **BEFORE PUTTING THE STANDARD ROTARY CUTTER INTO SERVICE, ATTACHING TO TRACTOR 3-POINT LINKAGE, DETACHING STANDARD ROTARY CUTTER FROM TRACTOR, and CHECKING DRIVELINE/ CUTTER CLEARANCE** before operating the Standard Rotary Cutter.

ASSEMBLY AND SETUP

Install Slip Clutch PTO: ARC260SC, ARC272SC

1. Install slip clutch shield on gearbox using the (4) supplied bolts and washers that were previously removed from the manual holder using a 1/2" socket and extension.



4. Remove safety chain from bag on PTO Shaft and attach the clip to the side of the slip clutch shield as shown.



2. Push PTO driveline onto input shaft towards gearbox aligning the holes for the retaining bolt.



5. **ASSEMBLY IS NOT COMPLETE!** Please read pp. 16-18, **BEFORE PUTTING THE STANDARD ROTARY CUTTER INTO SERVICE, ATTACHING TO TRACTOR 3-POINT LINKAGE, DETACHING STANDARD ROTARY CUTTER FROM TRACTOR, and CHECKING DRIVELINE/ CUTTER CLEARANCE** before operating the Standard Rotary Cutter.

IMPORTANT

Avoid Damage!

Only use a 1/2" Grade 8 hex bolt, identified by six radial lines located on the bolt head.

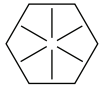

**Grade 8
Hex Bolt**

3. Utilizing the access hole in the slip clutch guard insert the Grade 8 retaining bolt and tighten using 3/4" wrench and socket with extension.



ASSEMBLY AND SETUP

Before Putting the Standard Rotary Cutter Into Service

IMPORTANT

Avoid Damage!

New units ship without oil in the gearbox and without grease in the grease fittings. **UNIT MUST BE SERVICED BEFORE FIRST USE.**

1. Use TYPE/Grade II Tube Grease to grease the two fittings on the PTO shaft. There is one on each end of the shaft in the universal joint.



2. Use TYPE/Grade II Tube Grease to grease the two fittings on each end of the PTO Shield.



3. Re-install the PTO shield by sliding the shield over the universal joint making sure the shield locks in place.



4. Use TYPE/Grade II Tube Grease to grease the two fittings in the rear tailwheel assembly.



5. Using a 7/8" wrench, remove the fill plug and using a 7mm wrench, remove the drain plug. Both are located on the backside of the gearbox.

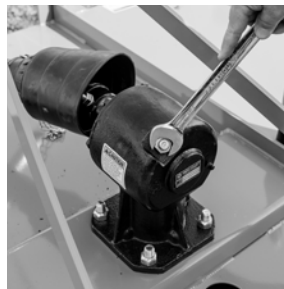

6. Fill the gearbox with 80W/90 or 85W/140 gear oil until level with the drain plug. (Holds approx. 1 quart)



7. Replace and tighten both plugs on the gearbox.



ATTACHING / DETACHING

Attaching to Tractor 3-Point Linkage



Avoid serious injury or death!

Whenever rotary cutter is attached, put transmission in PARK position and check the full range of the hitch for interference, binding, or PTO separation. DO NOT stand between tractor and rotary cutter.

1. Back up tractor to rotary cutter with hitch points approximately in alignment.
2. Engage tractor parking brake and/or place transmission in PARK.
3. Shut off tractor engine and remove key.
4. Remove center link mounting hardware and hitch pin assemblies at both hitch masts.
5. Install tractor draft links on hitch pins. Secure with quick lock pins (stored on tractor draft links).

NOTE: If the draft links do not open wide enough to clear the hitch pin assemblies in their standard orientation, invert the hitch pins to allow inside hook-up.

6. Align center link with upper hole in rotary cutter lift arms and install center link mounting hardware.



Avoid serious injury or death!

Shut off tractor engine before attaching or detaching PTO driveline. Entanglement in rotating driveline can cause serious injury or death.

IMPORTANT

Avoid Damage!

Keep driveline and powershaft splines clean of paint, dirt and chaff. Apply grease to tractor PTO shaft before attaching PTO driveline.

7. Shut off tractor engine.
8. Raise tractor PTO shield, if equipped.

IMPORTANT

Avoid Damage!

DO NOT use shielding bell on driveline to lift driveline into position. Damage to shielding can occur.

9. Support driveline by cradling it in your hand.

10. Pull pin back toward rotary cutter. Align splines by rotating rotary cutter driveline. Push driveline onto tractor PTO shaft until pin snaps into place.
11. Pull back on shield to make sure driveline is locked.
12. DO NOT pull back on pin, this will release latch.
13. Lower tractor PTO shield, if equipped.

Detaching Standard Rotary Cutter from Tractor



Avoid injury!

To prevent personal injury caused by unexpected movement:

- a. Park rotary cutter on a level surface.
- b. Engage tractor parking brake and/or place transmission in PARK.
- c. Disengage PTO.
- d. Shut off tractor engine and remove key.

1. Park rotary cutter on a level surface, or block tail wheel(s) so rotary cutter cannot roll after detaching from the tractor.
2. Slowly push hitch control lever to lower rotary cutter close to the ground.
3. Engage tractor parking brake and/or place transmission in PARK.



Avoid serious injury or death!

Shut off tractor engine before attaching or detaching PTO driveline. Entanglement in rotating driveline can cause serious injury or death.

4. Shut off tractor engine and remove key.
5. Raise tractor PTO shield, if equipped.



Avoid serious injury or death!

Ensure that all movement of PTO driveline and blades has stopped before detaching the rotary cutter. Entanglement in rotating driveline or being struck by blades can cause serious injury or death.

DETACHING / ADJUSTMENTS

Detaching Standard Rotary Cutter from Tractor Cont.

IMPORTANT

Avoid Damage!

DO NOT use shielding bell on driveline to lift driveline into position. Damage to shielding can occur.

6. Push pin in and slide driveline off tractor shaft.
7. Support and collapse driveline completely and lower onto PTO holder or onto rotary cutter deck.
8. Lower tractor PTO shield, if equipped.
9. Remove quick-lock pins from hitch pins and install in storage position on tractor draft links.
10. Remove and lower tractor draft links from hitch pins.
11. Disconnect center link from mast straps. Position tractor center link in transport location. Reinstall center link pin/hardware.
12. Carefully drive tractor away.

Checking Driveline/Cutter Clearance

IMPORTANT

Avoid Damage!

Prevent driveline damage from contact with frame or machine damage from contact with tractor tires. Raise rotary cutter slowly and check for interference. If necessary, shorten center link or lengthen lift links to provide clearance to full lift height.

1. Raise rotary cutter slowly and check for clearance between driveline shield and rotary cutter deck.
2. Check clearance between tractor tires and foot guards or chain deflector.
3. Check to see if hitch height position will provide clearance desired.

NOTE: Final adjustments should be made before operating the rotary cutter. (See p. 21, **ADJUSTING CUTTING HEIGHT AND ANGLE.**) Center link should be installed in lowest hole at tractor end if there are multiple holes. Lift height may also be limited by installing stops on rockshaft control lever bracket.

4. Shorten center link or lengthen lift links to provide clearance. (See tractor Operator's manual.)

IMPORTANT

Avoid Damage!

PTO driveline may be too long for some tractor models, causing tractor transaxle damage. Hold driveline sections parallel to each other and check for a minimum of six inches overlap.

5. Raise and lower rotary cutter slowly to check for binding or interference. Check cutter-to-tractor driveline telescoping length to ensure that it does not bottom out. Modify driveline if necessary. (See pp. 19-20, **SIZING THE PTO SHAFT, CHECK DRIVELINE MAXIMUM LENGTH, CHECK DRIVELINE MAXIMUM ANGLE.**)

ADJUSTMENTS

Sizing the PTO Shaft

Refer to Figure 3

1. Detach the driveline from tractor PTO shaft and pull outer and inner drivelines apart.
2. Reattach outer driveline to tractor PTO shaft. Pull on inner and outer drivelines to ensure universal joints are properly secured.
3. Hold inner and outer drivelines parallel to each other:
 - a. Measure 1" ("B" dimension) back from outer driveline universal joint shield and make a mark at this location on the inner driveline shield.
 - b. Measure 1" ("B" dimension) back from inner driveline universal joint shield and make a mark at this location on the outer driveline shield.
4. Remove driveline from tractor and gearbox shafts.
5. Measure from end of inner shield to scribed mark ("X" dimension). Cut off inner shield at the mark. Cut same amount off the inner shaft ("X1" dimension).
6. Measure from end of outer shield to scribed mark ("Y" dimension). Cut off outer shield at the mark. Cut same amount off the outer shaft ("Y1" dimension).
7. Remove all burrs.
8. Continue with **CHECK DRIVELINE MAXIMUM LENGTH.**

Figure 3 - Driveline Shortening

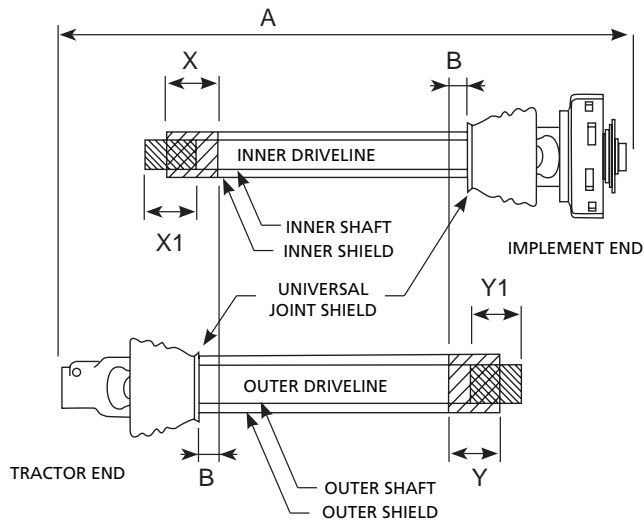

Check Driveline Maximum Length

Refer to Figure 4

Make sure driveline's collapsible length is acceptable.

The driveline maximum allowable length must, when fully extended, have a minimum overlap of the profile tubes by not less than 1/3 the free length with both inner and outer profile tubes being of equal length.

1. Apply multi-purpose grease to the inside of the outer shaft and reassemble the driveline.
2. Assemble the two driveline profiles together with 1/3 of the profile tubes overlapping as shown in Figure 7. Once assembled, measure and record the maximum allowable length for future reference.

Figure 4 - Driveline Maximum Extended Length

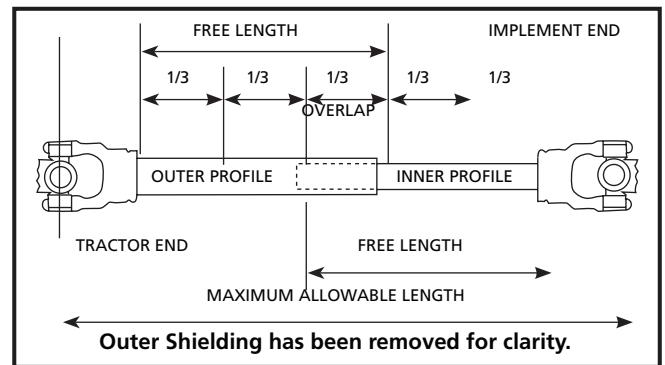

3. Attach inner driveline yoke to the rotary cutter's gearbox shaft. Attach outer driveline yoke to the tractor's PTO shaft.
4. Move yoke ends of driveline back and forth to ensure they are secured to the tractor and rotary cutter shafts. Reattach any end that is loose.

IMPORTANT

Avoid Damage!

Small chains are supplied with the driveline. They must be attached to the inner and outer driveline shields and to the rotary cutter and tractor to restrict shield rotation.

5. Hook driveline safety chain on the tractor end of driveline to rotary cutter frame. Re-latch safety chain to the driveline shield.
6. Hook driveline safety chain on the rotary cutter end of driveline to the rotary cutter frame. Re-latch safety chain to driveline shield.

ADJUSTMENTS

Check Driveline Maximum Length Cont.

7. Start tractor and raise rotary cutter just enough to remove support blocks.
8. Slowly engage tractor hydraulic 3-point control lever to lower the rotary cutter while checking for sufficient drawbar clearance. Move drawbar in, aside or remove if required.
9. Raise and lower implement to find maximum extended driveline length. Check to make certain the driveline does not exceed maximum allowable length recorded in Step 2.
10. If needed, set tractor 3-point lift height to stop driveline from exceeding maximum allowable length.
11. Continue with **CHECK DRIVELINE MAXIMUM ANGLE.**

Check Driveline Maximum Angle

Refer to Figure 5

IMPORTANT

Avoid Damage!

To avoid premature driveline breakdown, **DO NOT** exceed an angle of 25° up or down with the driveline while driveline is rotating. If needed, set tractor 3-point left lever to limit driveline angle at a maximum of 25° up.

1. Raise and lower implement to find maximum driveline angle. Check to make certain the driveline does not exceed 25° up or down.
2. If needed, set tractor 3-point lift height to keep driveline from exceeding 25° up.

Figure 5 - Check Driveline Maximum Angle

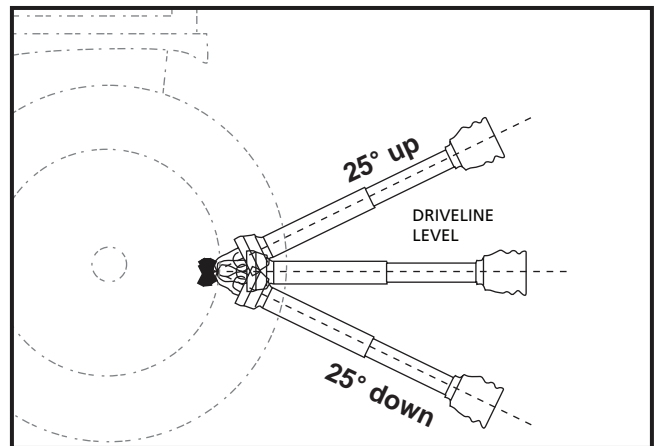

OPERATION

Preparing Rotary Cutter for Operation

Only qualified people should operate the rotary cutter. Wear close fitting clothing and safety equipment appropriate to the job. The power unit should be equipped with a Roll-Over Protection System (ROPS) and seat belt. Before beginning operation, clear the work area of objects that may be picked up and thrown. Check for ditches, stumps, holes, or other obstacles that could upset the power unit or damage the rotary cutter. Always turn off the power unit engine, set parking brake, and allow rotary cutter blades to come to a complete stop before dismounting power unit.

DANGER

Avoid serious injury or death!

- **DO NOT engage tractor PTO when rotary cutter is in fully raised position (transport position).**
- **Keep all persons away from machine when raising and lowering rotary cutter.**

IMPORTANT

Avoid Damage!

To prevent damage to the rotary cutter when lowering it, adjust the hitch lowering speed.

1. Adjust tractor rockshaft rate-of-drop. Allow at least two seconds for rotary cutter to lower from full lift height to the ground. (See tractor Operator's manual.)
2. If equipped, disengage tractor hitch/rockshaft control lever from transport lock position and lower rotary cutter to the ground. (See tractor Operator's manual.)
3. Adjust tractor lift links to level rotary cutter side-to-side. (See tractor Operator's manual.)
4. Adjust cutting height and angle. (See **ADJUSTING CUTTING HEIGHT AND ANGLE**)

Adjusting Cutting Height and Angle

DANGER

Avoid serious injury or death!

Ensure that all movement of PTO driveline and blades has stopped before detaching the rotary cutter. Entanglement in rotating driveline or being struck by blades can cause serious injury or death.

1. Lower rotary cutter until rear wheel just touches or is slightly above ground.
2. Engage tractor parking brake and/or place transmission in PARK.
3. Disengage PTO.
4. Shut off tractor engine and remove key.
5. Wait until all moving parts have stopped.
6. Disconnect PTO driveline from tractor.
7. Loosen and remove bolt, flat washers and lock nut(s) from tailwheel adjustment plate (see Figure 6).

Figure 6

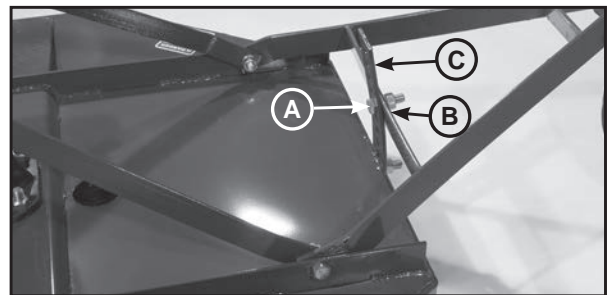

A-B Lock Nut, Washers, Bolt
C- Adjustment holes

8. Raise tail wheel to highest position and install bolt(s), flat washers and lock nut.
9. Using rockshaft control lever, position front of rotary cutter at desired cutting height at location.
10. Adjust depth stop. (See tractor Operator's manual.)
11. Adjust center link so rear of rotary cutter is approximately 2 inches (51 mm) higher than front.
12. Lower tailwheel to support rear of the rotary cutter.

OPERATION

Adjusting Cutting Height and Angle Cont.

NOTE: The rotary cutter should be operated at the highest position for optimal cutting results. This will help prevent the blades from striking the ground, reducing blade wear and placing undue strain on the rotary cutter. For best results under heavier cutting conditions, always tilt the rotary cutter approximately 2 inches (51mm) lower in the front. This tilt decreases horsepower requirements and increases potential ground speed. When fine shredding is desired, adjust rotary cutter deck level to slightly lower in the rear. This will keep the foliage under the rotary cutter until thoroughly shredded. More power is required for shredding.

13. Install bolt, flat washers and lock nut into one of the bolt holes that aligns with hole in wheel support (see Figure 6). Tighten lock nut.

NOTE: The rear of the rotary cutter is supported by the tailwheel(s) and the draft links support the front to allow the rotary cutter to follow the ground contour. Each rotary cutter can be adjusted to several cutting heights by moving the rockshaft control lever in conjunction with moving the tailwheel adjustment bolt(s) among the height adjustment holes (see Figure 6). All Standard Rotary Cutter models have a cutting height range of 1.5" to 9".

IMPORTANT

Avoid Damage!

Loosening the center link may allow the driveline to contact the rotary cutter frame or tractor tires in order to contact the foot guards or chain shield. Raise the rotary cutter slowly and check for interference. Lengthen tractor lift links to provide clearance to full height.

NOTE: Lift height may also be limited by installing stops on rockshaft control lever bracket.

14. Lengthen tractor lift links, if necessary, to provide clearance.

Follow Safe Operating Procedures

1. BEFORE EACH USE, perform maintenance as required in the **MAINTENANCE** section, pp. 29-35.
2. Start tractor per tractor operator's manual.
3. Raise/lower 3-point hitch to place rotary cutter in working position.
4. Look to be sure no one is near rotary cutter.
5. With tractor at idle speed, slowly engage PTO drive.



Avoid serious injury or death!

Stay clear of rotating driveline. Only operate with driveline shields in place and with all equipment in good condition. Failure to heed these warnings may result in personal injury or death.

6. Set the tractor throttle for appropriate PTO speed (540 RPM).



Avoid serious injury or death!

Rotating cutter blades. Stand clear until all motion has stopped. To avoid an accidental fall from tractor and possible injury by rotary cutter, it is recommended that tractor be equipped with Roll-Over Protection System (ROPS), and that a seatbelt be used by the operator for all cutting operations.

7. Place the tractor in gear and proceed forward.

NOTE: Tractor forward speed should be controlled by gear selection, not engine speed. For maximum cutting efficiency, forward speed should allow rotary cutter to maintain a constant, maximum blade speed. If rotary cutter stalls or tractor engine bogs, disengage PTO. Before re-engaging PTO, position rotary cutter in a cut area and reduce tractor throttle to idle. If rotary cutter continuously stalls, select lower gear and/or increase cutting height.



Avoid serious injury or death!

Keep riders off. Riders are subject to injury or death such as being struck by foreign objects and being thrown off the machine. Riders may also fall off and be run over by machine. Riders also obstruct the operator's view resulting in the machine being operated in an unsafe manner.

OPERATION / ACCESSORIES

Follow Safe Operating Procedures Cont.

DANGER

Avoid serious injury or death!

Never operate rotary cutter when other people are in the vicinity. Debris can be thrown hundreds of feet. Keep all deflectors in place, including those on discharge opening at front and rear of deck. Lower rotary cutter to the ground before starting the machine. Engage tractor PTO and gradually increase the speed. Operate tractor at rated PTO speed. If engine speed is too slow or too fast, the rotary cutter may not perform properly. Where conditions make it necessary to slow ground speed, shift to a lower gear rather than reducing engine speed. The engine will maintain rated speed and keep rotary cutter running at optimum cutting speed. Operate rotary cutter from tractor seat only. Never adjust the rotary cutter while it is in motion. Slow down when turning or traveling over rough ground. Avoid holes when operating on hillsides. Tractor roll-over could result. Shut off tractor engine and engage tractor parking brake and/or place transmission in PARK when leaving tractor. Remove key when leaving tractor unattended. Components behind shields may rotate several minutes after power is shut off. Look and listen for evidence of rotation before removing shielding.

Installing Optional Front Rubber Guard - All Models

DANGER

Avoid serious injury or death!

DO NOT install the front guard while the implement is attached to a tractor. Guard installation must be completed with the rotary cutter securely blocked up on sufficient supports.

Included Hardware

(Qty varies based on guard size)



Carriage Bolt
3/8"-16 x 1-1/2"



Flat Washer 3/8"



Nylon Lock Nut
3/8"-16

Reference Diagram

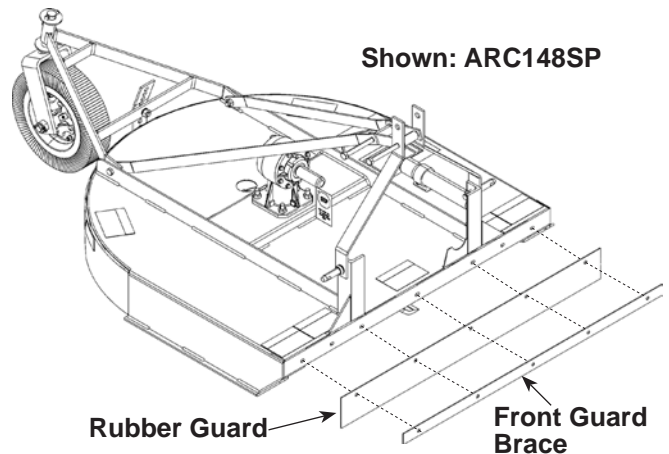

1. Align the bolt holes of the front guard brace and rubber guard with bolt holes on front of Rotary Cutter deck.
2. Starting with the holes closest to the center of the deck, insert a 3/8"-16 x 1-1/2" carriage bolt through the deck, rubber guard, and front guard brace, with threads facing outward (away from Rotary Cutter blades).
3. Secure each carriage bolt with a 3/8" flat washer and 3/8"-16 nylon lock nut. Torque lock nuts to correct specifications.



ACCESSORIES

Installing Optional Front Chain Guard - All Models



Avoid serious injury or death!
DO NOT install the front guard while the implement is attached to a tractor. Guard installation must be completed with the rotary cutter securely blocked up on sufficient supports.

Included Hardware
(Qty varies based on guard size)

-  Carriage Bolt
3/8"-16 x 1-1/4"
-  Flat Washer 3/8"
-  Nylon Lock Nut
3/8"-16

Reference Diagram

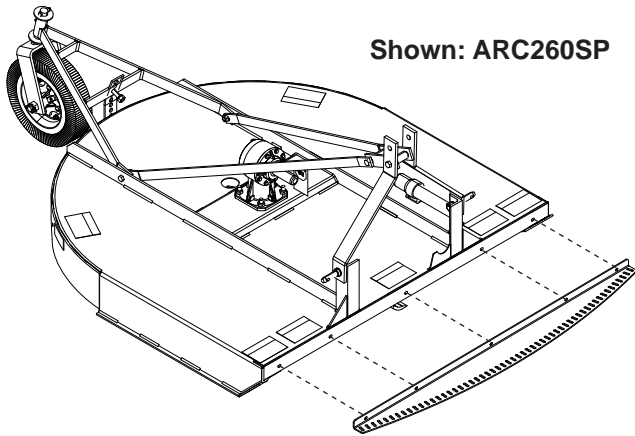

1. Align Front Chain Guard bolt holes with bolt holes on rotary cutter deck.
2. Insert one 3/8"-16 x 1-1/4" carriage bolt through the bolt holes on the rotary cutter deck and chain guard. Bolt threads should face outward, away from the cutting blades.

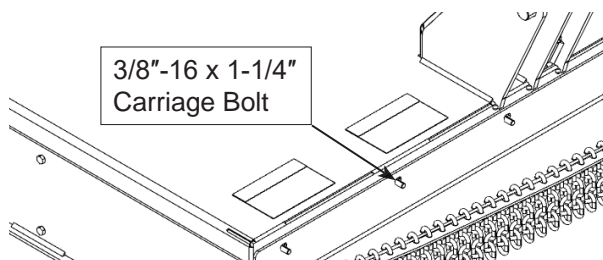

Insert carriage bolts with threads facing outward.

3. Secure each bolt with a 3/8" flat washer and 3/8"-16 nylon lock nut.

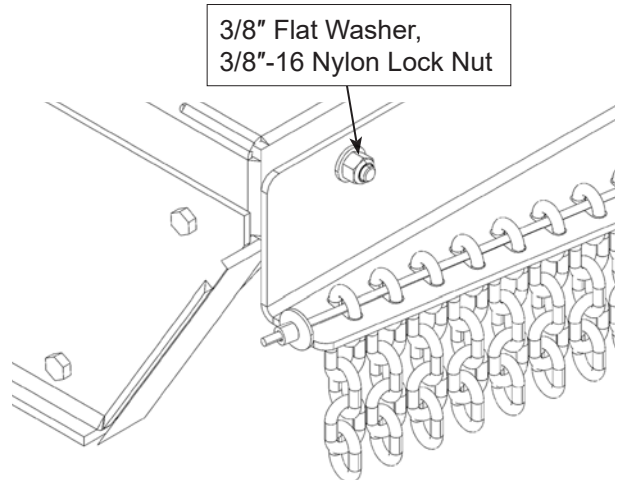

Secure bolts with flat washer and lock nut.

4. Use a 9/16" wrench and socket to tighten the lock nuts and carriage bolts to correct torque specifications.



ACCESSORIES

Installing Optional Rear Metal Guard - ARC148SP



Avoid serious injury or death!
DO NOT install the rear guard while the implement is attached to a tractor. Guard installation must be completed with the rotary cutter securely blocked up on sufficient supports.

Included Hardware

-  Carriage Bolt (x3)
3/8"-16 x 1-1/4"
-  Flat Washer (x3)
3/8"
-  Nylon Lock Nut (x3)
3/8"-16

Reference Diagrams

Guard Bolt Hole 2

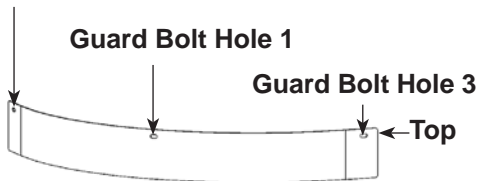

Guard ships flat and must be formed around rear deck.

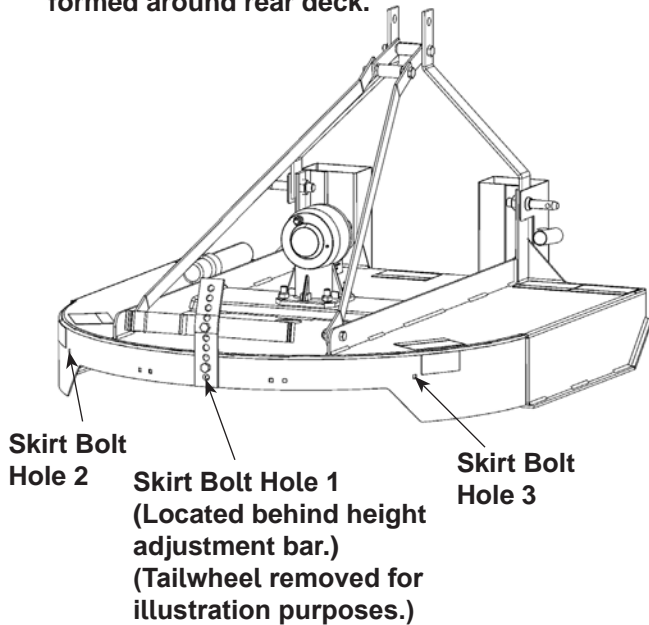

1. Loosen, but **DO NOT** remove the two 5/8"-11 x 2 hex bolts securing the height adjustment bar to the tailwheel assembly and rotary cutter skirt to create slack in the connection. The slack allows installers to slide the top of the rear guard between the height adjustment bar and the rotary cutter skirt.

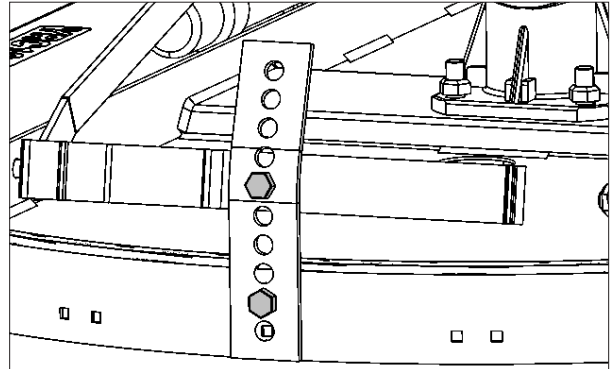

2. Align Guard Bolt Hole 1 with Skirt Bolt Hole 1 and the bottom bolt hole of the height adjustment bar.
3. Insert one carriage bolt through all the bolt holes. Bolt threads should face outward, away from the blade pan.
4. Secure bolt with one flat washer and one nylon lock nut and hand tighten.

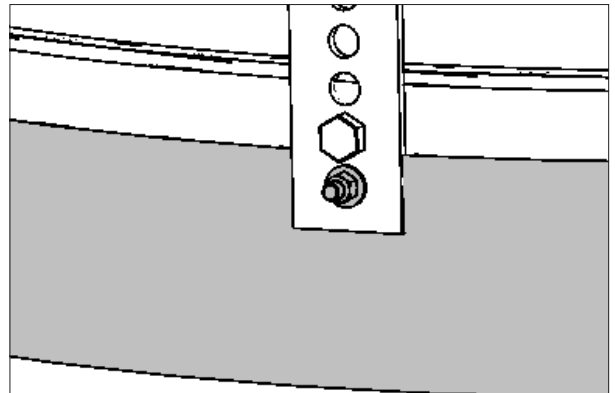

5. Smooth the guard around the left side of the rotary cutter skirt, following the curve of the cutter deck.
6. Align Guard Bolt Hole 2 with Skirt Bolt Hole 2, then insert one carriage bolt through both bolt holes. Bolt threads should face outward, away from the blade pan.
7. Secure bolt with one flat washer and one nylon lock nut and hand tighten.

ACCESSORIES

Installing Optional Rear Metal Guard - ARC148SP Continued

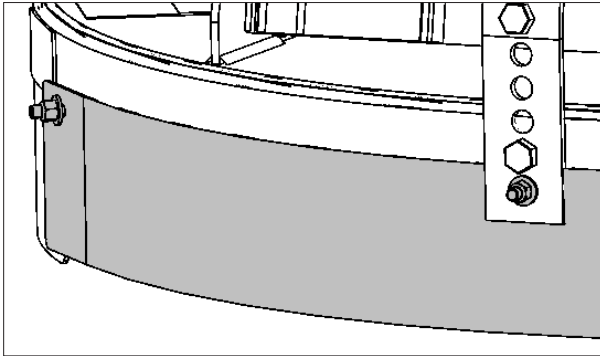

8. Smooth the guard around the right side of the rotary cutter skirt, following the curve of the cutter deck.
9. Align Guard Bolt Hole 3 with Skirt Bolt Hole 3, then insert one carriage bolt through both bolt holes. Bolt threads should face outward, away from the blade pan.
10. Secure bolt with one flat washer and one nylon lock nut and hand tighten.

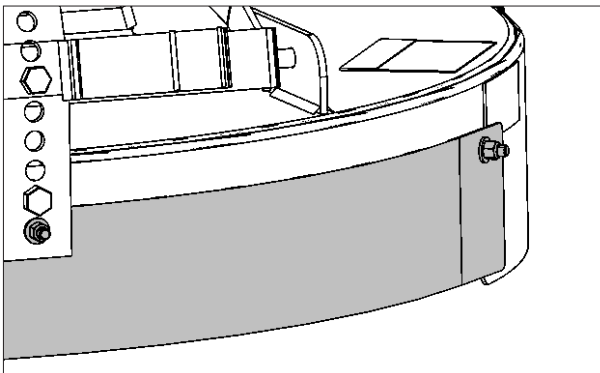



11. Fully tighten all carriage bolts and lock nuts by order of installation, then fully tighten the hex bolts securing the height adjustment bar to the tailwheel assembly and rotary cutter skirt.
12. Assembly of the rear guard is now complete.

Installing Optional Rear Metal Guard - ARC260SP, ARC260SC, ARC272SC



Avoid serious injury or death!
DO NOT install the rear guard while the implement is attached to a tractor. Guard installation must be completed with the rotary cutter securely blocked up on sufficient supports.

Included Hardware

-  Carriage Bolt (x4)
3/8"-16 x 1-1/4"
-  Flat Washer (x4)
3/8"
-  Nylon Lock Nut (x4)
3/8"-16

Reference Diagrams

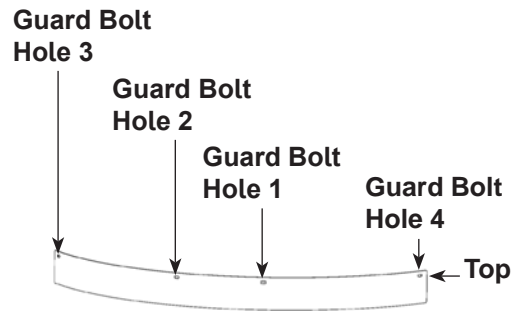

Guard ships flat and must be formed around rear deck.

Model ARC260SP, ARC260SC

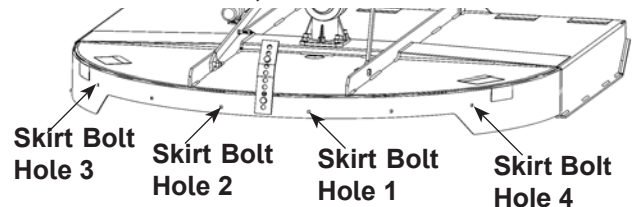

Model ARC272SC

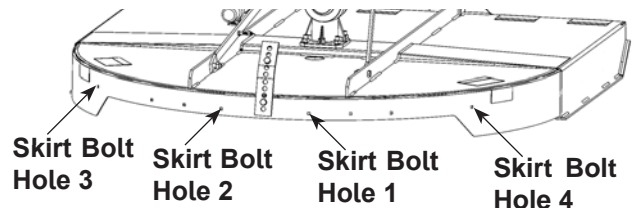

(Rear guard installation continued on next page.)

ACCESSORIES

Installing Optional Rear Metal Guard - ARC260SP, ARC260SC, ARC272SC Continued

1. Loosen, but DO NOT remove the two 5/8"-11 x 2 hex bolts securing the height adjustment bar to the tailwheel assembly and rotary cutter skirt to create slack in the connection. The slack allows installers to slide the top of the rear guard between the height adjustment bar and the rotary cutter skirt.

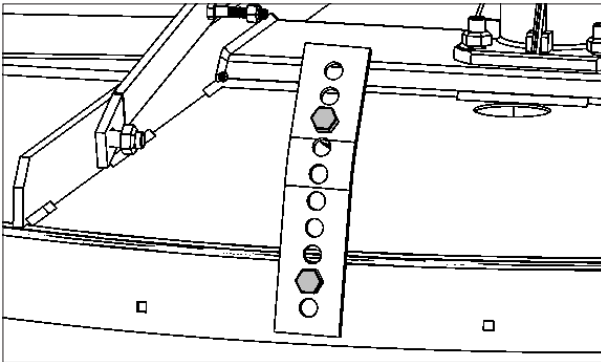

2. Align Guard Bolt Hole 1 with Skirt Bolt Hole 1, then insert one carriage bolt through both bolt holes so that the threads face outward, away from the blade pan. Secure bolt with one flat washer and one nylon lock nut and hand tighten.
3. Align Guard Bolt Hole 2 with Skirt Bolt Hole 2, then insert one carriage bolt through both bolt holes so that the threads face outward, away from the blade pan. Secure bolt with one flat washer and one nylon lock nut and hand tighten.

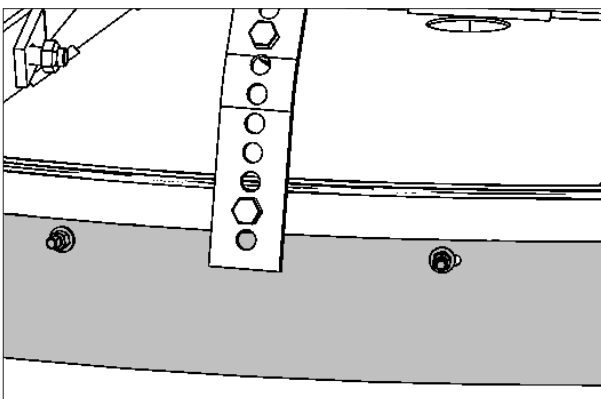

4. Smooth the guard around the left side of the rotary cutter skirt, following the curve of the cutter deck.

5. Align Guard Bolt Hole 3 with Skirt Bolt Hole 3, then insert one carriage bolt through both bolt holes with the threads facing outward, away from the blade pan. Secure bolt with one flat washer and one nylon lock and hand tighten.

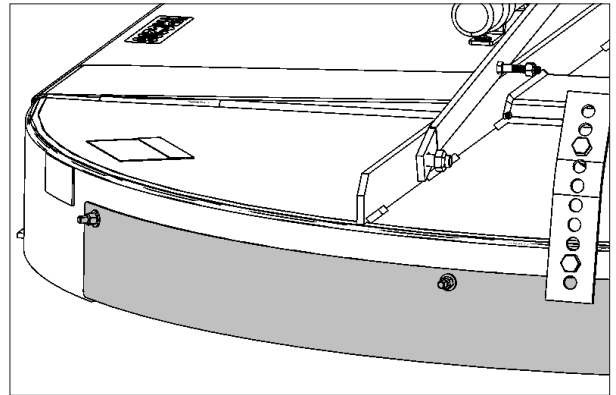

6. Smooth the guard around the right side of the rotary cutter skirt, following the curve of the cutter deck.
7. Align Guard Bolt Hole 4 with Skirt Bolt Hole 4, then insert one carriage bolt through both bolt holes with the threads facing outward, away from the blade pan. Secure bolt with one flat washer and one nylon lock and hand tighten.

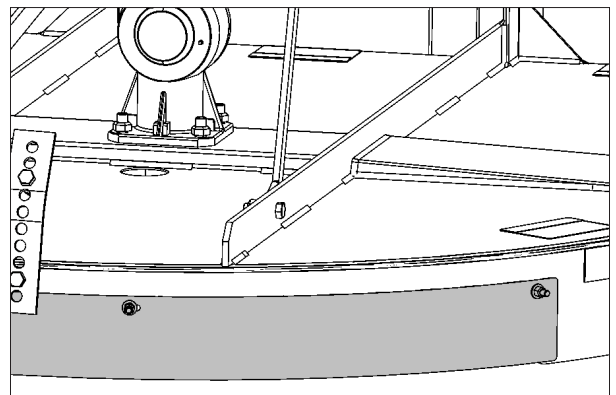

8. Fully tighten all carriage bolts and lock nuts by order of installation, then fully tighten the hex bolts securing the height adjustment bar to the tailwheel assembly and rotary cutter skirt. Assembly of the rotary cutter rear metal guard is now complete.

ACCESSORIES

Installing Optional Rear Chain Guard - All Models



Avoid serious injury or death!

DO NOT install the rear guard while the implement is attached to a tractor. Guard installation must be completed with the rotary cutter securely blocked up on sufficient supports.

5. Use a socket and wrench to tighten the lock nuts and carriage bolts to correct torque specifications.

NOTE: Tighten the carriage bolts and lock nuts in sequential order, starting at one end and moving towards the opposite end.

Included Hardware

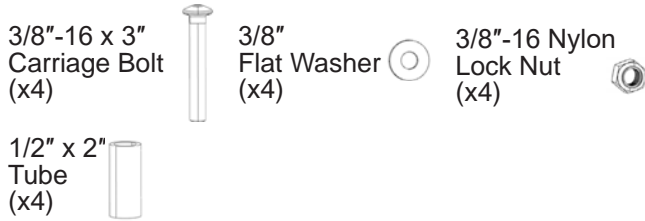

1. Insert one carriage bolt through each bolt hole on the rotary cutter deck. Bolt threads should face outward, away from the cutting blades.

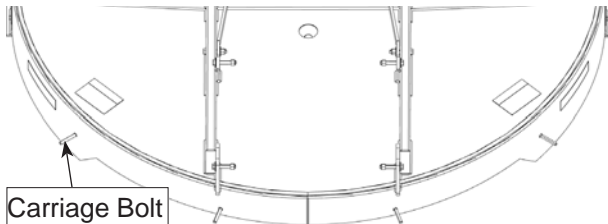

Insert carriage bolts with threads facing outward. (Tailwheel removed for illustration purposes).

2. Slide one 1/2" x 2" tube spacer onto each carriage bolt.
3. Hang the rear chain guard onto the bolts and spacers.
4. Secure each bolt with a flat washer and nylon lock nut. Hand-tighten the lock nuts.

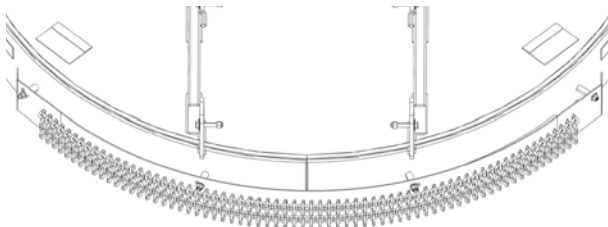

Install spacers, rear chain guard, flat washers, and nylon lock nuts.

MAINTENANCE

Maintenance Safety Guidelines

DANGER

Avoid serious injury or death!

Ensure that all movement of PTO driveline and blades has stopped before detaching the rotary cutter. Entanglement in rotating driveline or being struck by blades can cause serious injury or death. Components will be hot after operation. Let all components cool before servicing. Replace all shields after lubricating or servicing.

CAUTION

Avoid injury!

To help prevent personal injury caused by unexpected movement, be sure to service the rotary cutter on a level surface.

Before servicing or adjusting rotary cutter connected to a tractor:

1. Lower rotary cutter to the ground.
2. Engage tractor parking brake and/or place transmission in PARK.
3. Disengage PTO.
4. Shut off tractor engine and remove key.
5. Wait until all moving parts have stopped.
6. Disconnect PTO driveline from tractor.

The blades and blade pan may rotate for several minutes after PTO is shut off. Look and listen for rotating driveline to stop before working on the rotary cutter.

When servicing blades or blade pan, it will be necessary to work underneath the rotary cutter. Be sure to support rotary cutter frame at all four corner locations with safety shop stands to prevent accidental lowering.

DO NOT position safety stands under tailwheel support because these components can rotate.

Maintenance Schedule

Perform scheduled maintenance as outlined in this section. Lower rotary cutter to the ground, turn off tractor and set parking brake before doing maintenance inspections or work. All bolts should be torqued as recommended in the Torque Specifications Chart (see p. 43) unless otherwise indicated.

CAUTION

Avoid injury!

DO NOT clean, lubricate, or adjust the rotary cutter while it is in motion.

MAINTENANCE BEFORE EACH USE

1. Check tractor tire air pressure. Refer to tractor Operator's Manual for recommended setting.
2. Check blades and spindles to be sure that no foreign objects such as wire or steel strapping bands are wrapped around them.
3. Check blade bolts for tightness. Locate blade hardware under hole in deck behind gear box. (Tighten to 425 ft./lbs.)

IMPORTANT

Avoid Damage!

Operating with loose blade hardware will damage the blade holder and blades.

4. Inspect blades for wear (see p. 33, **CHECKING BLADE WEAR**). Always replace both blades and bolts on the blade holder at the same time.
5. Make certain driveline shields are in place and in good repair.
6. Inspect tailwheel for wear, damage, or foreign objects. (Repair or replace if necessary.)
7. Before each use, see the Rotary Cutter diagram on page 29 for lubrication intervals and locations.
8. During operation, listen for abnormal sounds, which might indicate loose parts, damaged bearings, or other damage.

MAINTENANCE AFTER EACH USE

1. Clean all debris from rotary cutter especially underside of deck. When cleaning underside of deck, securely block machine into position.

IMPORTANT

Avoid Damage!

Check all hardware after first eight (8) hours of use and tighten all hardware to specifications.

MAINTENANCE

Lubrication Schedule

LUBRICATION BEFORE EACH USE

A. Driveline Universal Joints

1. Apply multi-purpose grease with grease gun.

B. Driveline Guard

1. Apply 2-3 pumps of multipurpose grease with grease gun to plastic fitting.

C. Driveline

1. Disconnect PTO Driveline.
2. Pull two sections apart.
3. Apply a thin coat of multi-purpose grease to inside of female section.
4. Re-assemble sections.

NOTE: Pull each section to be sure driveline and shields are securely connected. Make certain PTO shielding is in good condition. **DO NOT** grease outer or inner plastic shields.

D. Tailwheel Pivot Tube

1. Apply multi-purpose grease with grease gun.

E. Tailwheel

1. Apply multipurpose grease with grease gun.

F. Gearbox

1. Check oil level by removing oil level check plug on side of gearbox.
2. Add 80W/90 or 85W/140 gear oil if necessary to bring oil level to check plug hole.

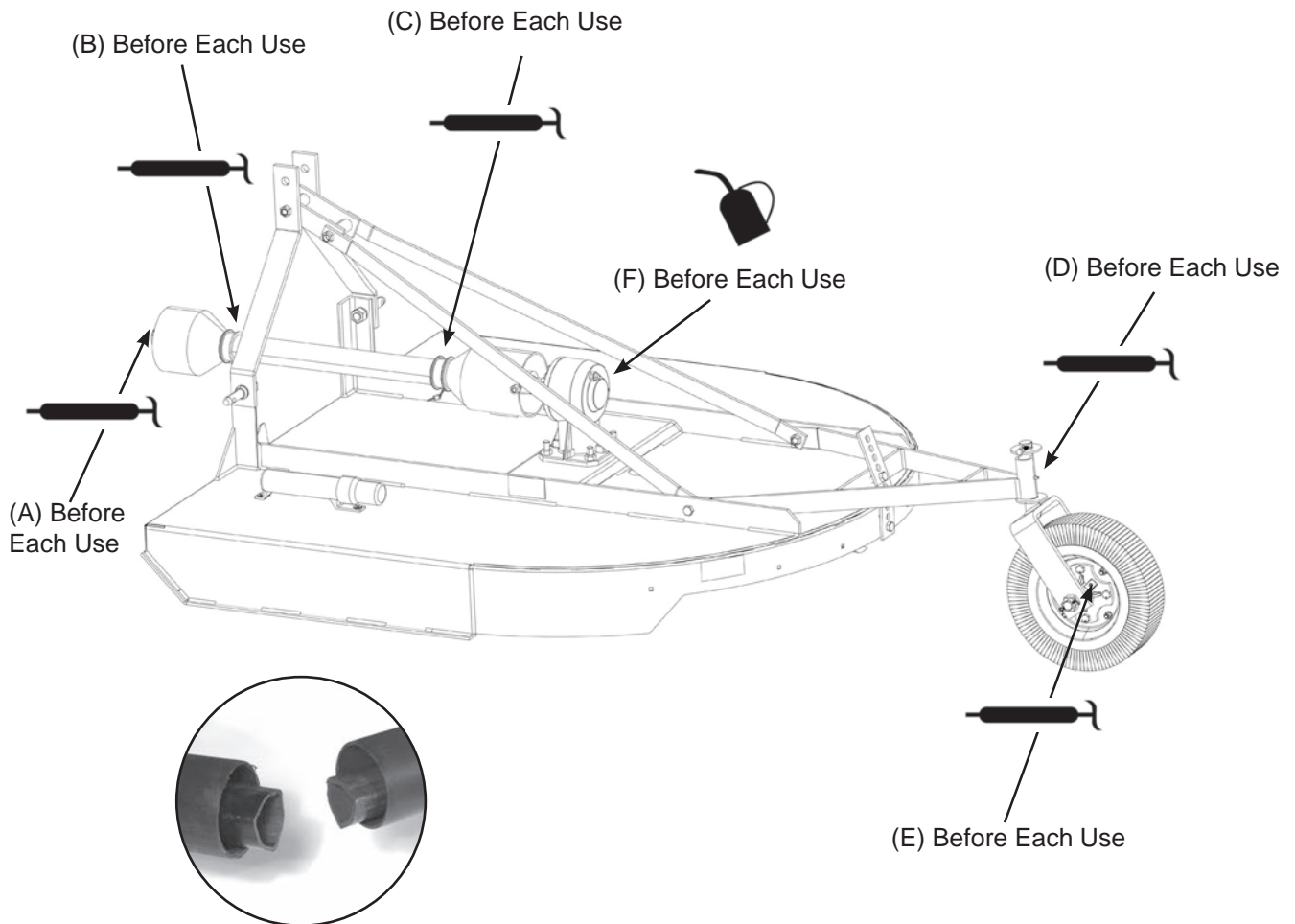

C2. Pull two sections apart.

MAINTENANCE

Disassembling Driveline Shield

1. Unhook driveline safety chain from one end of driveline.
2. Separate driveline into two (2) pieces.

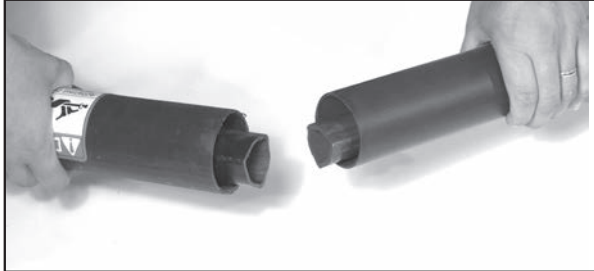

3. Slide the PTO shield back by using a screwdriver to apply pressure and release the locking collar. (There will be 3 tabs on the locking collar.) Once the locking collar is released, slide the PTO shield back.



4. If needed, separate white tab collar and slide shield tube back.



Avoid injury!

DO NOT operate PTO shaft without shielding installed.

Reassembling Driveline Shield

1. Replace white tabbed collar in groove of PTO shaft.

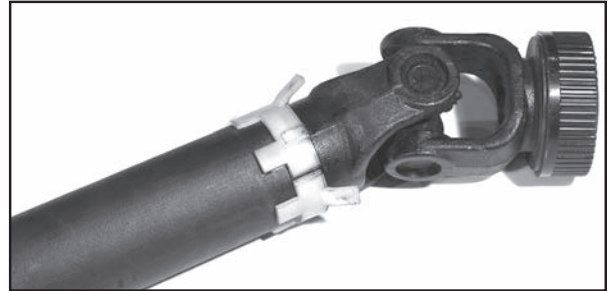

2. Slide driveline shield tube over white tab collar. Align slots/holes with holes in tube.

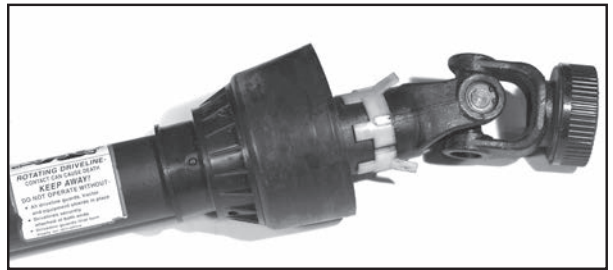

3. Slide universal joint cover up tube toward universal joint. Align grease fitting on shield with white square tabs on collars. This will properly align the position notch and all three (3) tabs.
4. Slide collar shield into place until locked.

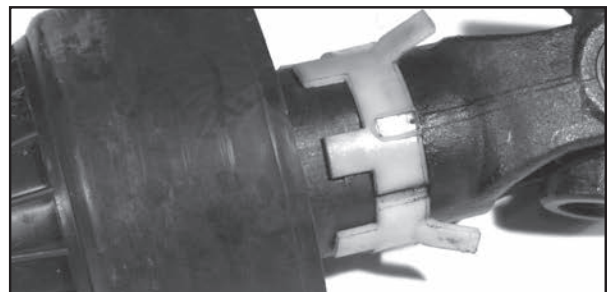

MAINTENANCE

Removing and Installing Driveline Shear Bolt - ARC148SP, ARC260SP

IMPORTANT

Avoid Damage!

Avoid shear bolt failure at startup by engaging the PTO slowly at low engine RPMs.

1. Disconnect driveline shield chain.
2. Bend back driveline shield cone.
3. Remove shear bolt and lock nut.

NOTE: If shear bolt has failed, it may be necessary to remove bolt using a hammer and punch.

4. Realign holes in yoke and shaft.
5. Install new 1/2" x 3-1/2" Grade 2 bolt and lock nut.

IMPORTANT

Avoid Damage!

Failure to use correct shear bolt may damage gearbox and/or PTO Shaft, thus voiding the warranty.

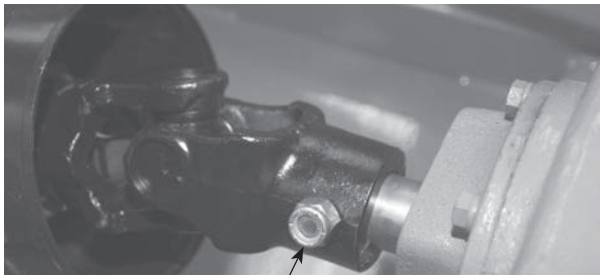

Shear Bolt and Lock Nut

NOTE: Driveline shield pulled back for illustration purposes. Cutter driveline components are protected from shock loads by a shear bolt.

Slip Clutch Operational Check - ARC260SC, ARC272SC

Slip clutch components must be free to rotate when necessary. After thirty days or more, linings of slip clutch may draw moisture. Linings may bond to metal parts causing slip clutch to be ineffective, resulting in machine damage. After the implement has been stored for thirty days or more perform the following operational check.

1. Loosen bolts and lock nuts (see Figure 7, D) progressively until tension is relieved.
2. To aid in determining slippage, scribe/mark a line across clutch plate and Belleville Spring.
3. With tractor at idle speed, engage tractor PTO drive 2 - 3 seconds. Clutch should slip without turning blades. **If clutch does not slip, contact an authorized Tar River Implements dealer.**
4. Tighten bolts and lock nuts progressively, leaving a gap of 1.5-1.8 mm between clutch plate and Belleville Spring.

Figure 7

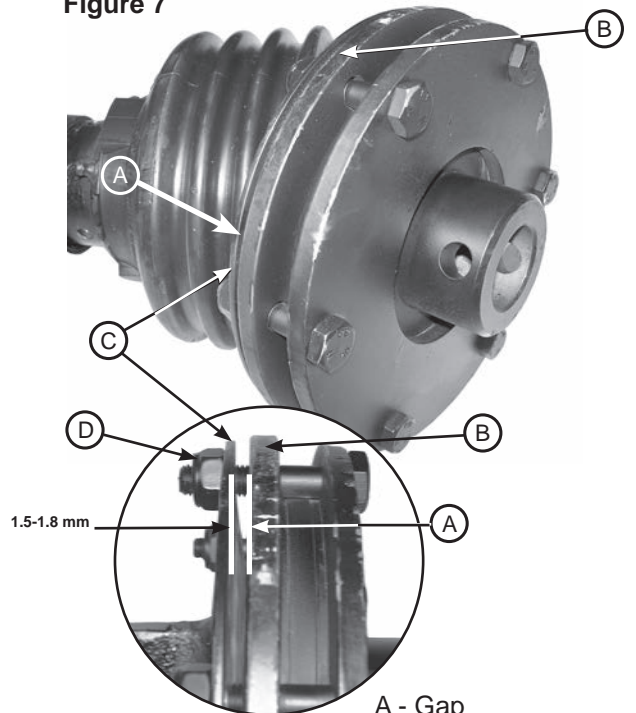

- A - Gap
- B - Clutch Plate
- C - Belleville Spring
- D - Cap Screw Lock Nut (6 used)

MAINTENANCE

Disassembling and Inspecting Slip Clutch

1. Remove slip clutch driveline.

IMPORTANT

Avoid Damage!

Belleville springs, which are part of the clutch assembly, maintain tension on all components. When disassembling the clutch assembly, release tension by progressively loosening the hardware.

2. Loosen bolts and lock nuts (see Figure 11, D) progressively until tension is relieved.
3. Friction disks may appear to be part of the hub or yoke, tap lightly on edge to separate.
4. Inspect clutch components for wear or damage. Repair parts as necessary.

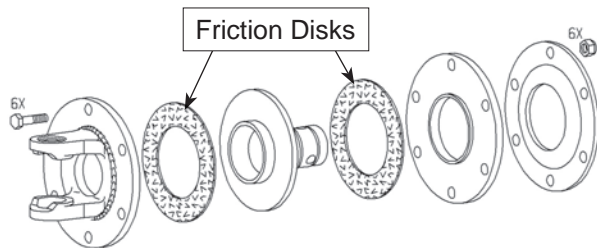

Slip clutch components.

Assembling Slip Clutch

Assemble slip clutch in reverse order of disassembly using the following instructions:

1. Install Belleville Spring with concave side facing towards yoke end.

IMPORTANT

Avoid Damage!

To avoid driveline damage, **DO NOT** overtighten bolts and lock nuts. A gap must be left between clutch plate and Belleville Spring (see Figure 7, B and C).

2. Tighten bolts and lock nuts progressively, leaving a 1.5-1.8 mm gap, between clutch plate and Belleville Spring.

Checking Blade Wear

IMPORTANT

Avoid Damage!

Operating rotary cutter with blades that are not alike will cause vibration. Always replace worn or broken blades in pairs. Never replace a single blade. Check blades regularly for wear or breakage.

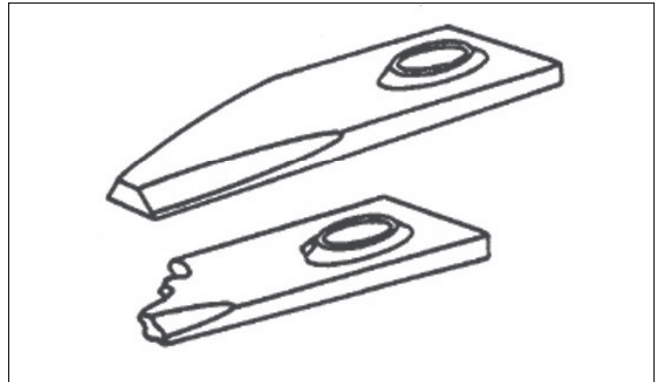

Replacing Blades

IMPORTANT

Avoid Damage!

Operating with loose blade hardware will damage the blade pan and blades. Whenever the blades have been removed or replaced, blade hardware **MUST** also be replaced. Check blade hardware torque after one hour of operation and every eight (8) hours thereafter.

NOTE: Suction blades have a cutting edge on one side only. Take note of blade rotation when installing blades. (See DIRECTION OF BLADE ROTATION in this section.)

DIRECTION OF BLADE ROTATION

NOTE: Rotary cutter shown is viewed from the top. Blades rotate counterclockwise.

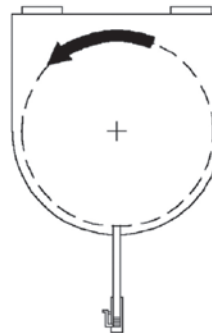

MAINTENANCE

Replacing Blades Continued

CAUTION

Avoid injury!

When replacing blades, blade hardware, and blade pan it will be necessary to work underneath rotary cutter. Be sure to support rotary cutter frame at all four corner locations with safety shop stands, blocks, or other firm supports to prevent accidental lowering. **DO NOT** position safety stands under wheel support(s) because these components can rotate.

1. Manually rotate driveline to align blade lock nut with access hole in top of deck behind gearbox.



2. Remove old blade bolts and blades.
3. Use new blade bolt hardware to install new blades.
4. Tighten blade bolt lock nuts to 425 ft-lbs.

Replacing Blade Pan

CAUTION

Avoid injury!

When replacing blades, blade hardware, and blade pan it will be necessary to work underneath rotary cutter. Be sure to support rotary cutter frame at all four corner locations with safety shop stands, blocks, or other firm supports to prevent accidental lowering. **DO NOT** position safety stands under wheel support(s) because these components can rotate.

1. Remove the blades. (See p. 33, **REPLACING BLADES**)
2. Remove cotter pin from output shaft of the gearbox underneath rotary cutter.
3. Loosen castle nut on the bottom of the output shaft (see Figure 8, A). **DO NOT** remove castle nut as it must hold the blade pan when it becomes loose.

Figure 8

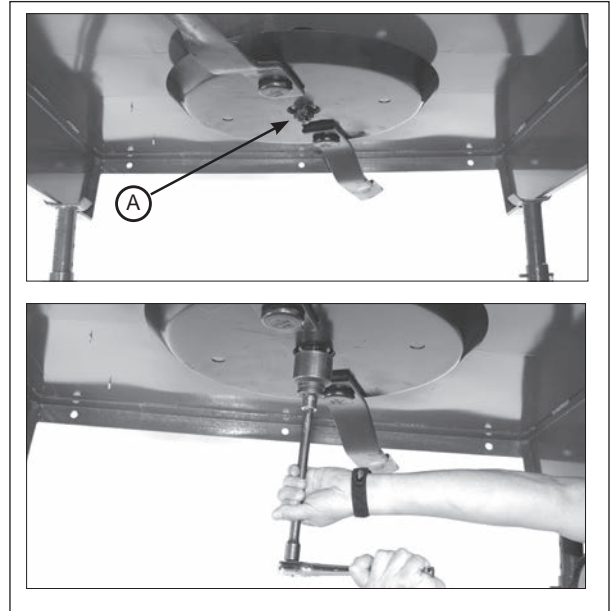

4. Tap with a hammer around the hub using a block of wood as shown Figure 9.

(Continued on next page.)

MAINTENANCE / STORAGE

Replacing Blade Pan Continued

Figure 9

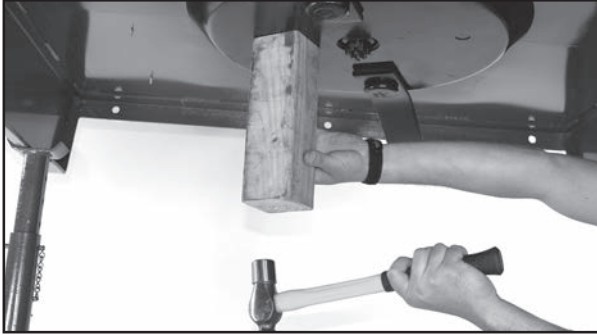

NOTE: The output shaft of the gearbox is tapered. A few taps around the hub will loosen the blade pan.

5. Remove castle nut slowly and allow the blade pan to be removed.
6. Remove blade pan.
7. To reinstall: hold blade pan in place and replace gearbox castle nut. Tighten gearbox castle nut and replace cotter pin.
8. Replace blades. (See p. 33, **REPLACING BLADES**)

Long-term Storage

IMPORTANT

Avoid Damage!

When the unit is going to be stored for an extended amount of time please perform the following steps to keep the oil seals from deteriorating.

1. Spray shaft extensions with a suitable dry film or similar preservative.
2. Pack grease around gearbox input seal to prevent drying and cracking.
3. Fill the gearbox with enough oil so that it covers the top of the input seal.
4. Remember to drain the oil back to the correct level before using again.
5. Check (and replace where necessary) blades, bolts, and nuts.
6. Clean rotary cutter and touch up any rust spots that may have appeared.
7. Replace any safety labels if damaged.
8. Store rotary cutter in a clean dry location.

CAUTION

Avoid injury!

Always use a tractor to position equipment for storage. Never attempt to move equipment by hand.

TROUBLESHOOTING

Problem	Possible Cause	Possible Remedy
Leaves a streak of uncut or partially cut grass.	Rotary cutter not level, side to side.	Level 3-pt. hitch linkage on tractor.
	Blade dull or bent.	Sharpen or replace blades.
	Blades unable to cut grass pressed by path of tractor.	Slow ground speed of tractor but keep engine running at full PTO RPM. Cutting lower will help.
	Build up of material under rotary cutter.	Clean rotary cutter.
Blade cuts grass lower in center of swath than at the edge.	Height of rotary cutter lower at rear or at front.	Adjust rotary cutter height and altitude so that rotary cutter rear and front are within 1/2" of same height.
Material discharges from rotary cutter unevenly, or discharges clumps of grass.	Grass or brush may be too high or thick.	Reduce ground speed but maintain 540 RPM at tractor PTO, or make two passes over material. Raise rotary cutter for the first pass and lower for the second pass, preferably cutting 90° to the first pass. Raise rear of rotary cutter high enough to permit material to discharge.
	Grass wet.	Allow grass to dry. Slow ground speed of tractor but keep engine running at full PTO RPM. Cutting lower will help.
Gearbox overheating.	Low on lubricant.	Fill to proper level.
	Improper lubricant type.	Replace with proper lubricant.
	Excessive trash build up around gearbox.	Remove trash.
Rotary cutter will not cut.	Shear bolt sheared. Model ARC148SP, ARC2060SP	Install new Grade 2 shear bolt.
Rotary cutter will not cut all the time.	Slip clutch slipping. Model ARC2060SC, ARC2072SC	Adjust slip clutch according to guidelines on p. 32.
Excessive vibration.	Possible build up of material on blade.	Clean blade pan.
	Blades locked into position.	Free blades so they swing free.
	Uneven wear on blade tips.	Weigh each blade. Weight should be within 1 oz.
	Broken blade.	Replace broken blade(s). Always replace in pairs.
	New blade or bolts not matched with worn blade or bolts.	Replace all blades and/or blade bolts.
Gearbox noisy.	Low oil in gearbox.	Check oil level. Add oil.

SPECIFICATIONS

	ARC148SP	ARC260SP, ARC260SC	ARC272SC
Weight	463 lbs	530 lbs	623 lbs
Cutting Width	48"	60"	72"
Overall Width	51"	64"	75"
Overall Length (Including Tailwheel)	77"	86"	93"
Hitch	Cat 1/ quick hitch compatible		
Deck Height	7.5"		
Cutting Height	1.5-9"		
Cutting Capacity	Up to 1"		
Horsepower	18-45	20-50	
Power Take-Off Speed	540 RPM		
Gearbox	45 hp cast iron housing, precision forged steel gears		
Gearbox Lubrication	80W/90		
Gearbox Lubrication Cap.	23 ounces		
Deck Material Thickness	12 Ga.		
Stump Jumper	1/8" Thick, Round 22.3" pan-type		
Blades	1/2"x3" Heat Treated Free Swinging w/ Suction Lift		
Blade Tip Speed	9,982 ft./min.	12,478 ft./min.	14,974 ft./min.
Driveline	ASAE Cat 4 Shear Bolt Protection	ARC260SP - ASAE Cat 4 Shear Bolt Protection ARC260SC - HD Slip Clutch PTO w/Ergonomic Quick Coupler	HD Slip Clutch PTO w/Ergonomic Quick Coupler
Tailwheel	15" Laminated Tire		
Safety Guards	See parts list for options		
Blade Bolt Size	42mm socket	42mm socket	42mm socket
Shear Bolt	1/2" x 3-1/2" Grd 2 Hex Bolt		N/A
Castle Nut on Gearbox	38mm socket		

This page
intentionally
left blank.

PARTS

OVERALL VIEW

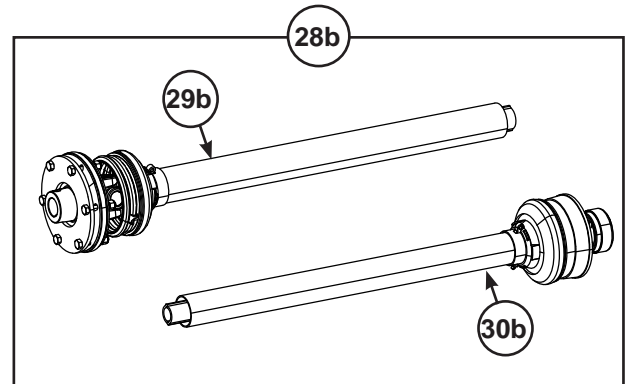
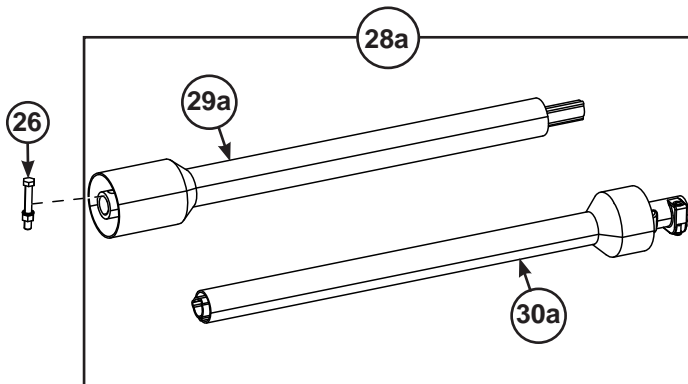
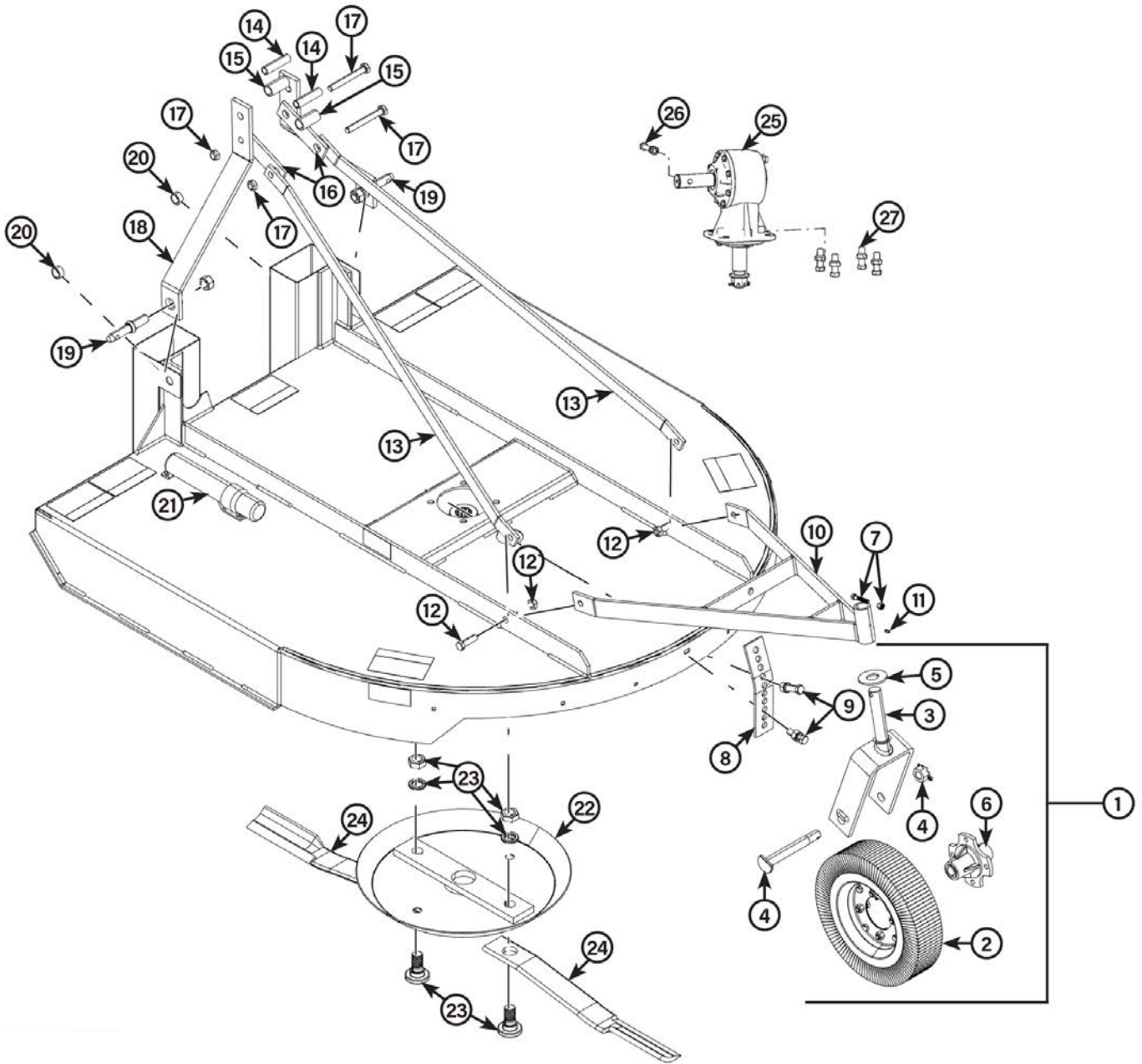

PARTS

Item Number	Part Number	Description
1	ARCRCTA	Rotary Cutter Tire/Wheel & Fork Assembly
2	ARCLTWWB	Laminated Tire and Wheel w/Bolts
3	ARCRCWF	Rotary Cutter Wheel Fork
4	ARCFHBWN	Fork & Hub Bolt w/ nut
5	ARC114W	1-1/4" Flat Washer
6	ARCHUB	Rotary Cutter Wheel Hub
7	ARCWFBWN	Wheel Fork Bolt w/Nut
8	ARC9000542	Rotary Cutter Height Adjuster
9	RCAFHAH	Rotary Cutter A-Frame Height Adjuster Hardware (4pk)
10	ARC9000533	4' Rotary Cutter A-Frame Assembly
10	ARC9000534	5' & 6' Rotary Cutter A-Frame Assembly
11	ARCGZ	Grease Zerk (5pk)
12	NSRCBSH	Rotary Cutter Backstrap Hardware (4pk)
13	ARC9000535	4' Rotary Cutter Back Brace (2pk)
13	ARC9000536	5' Rotary Cutter Back Brace (2pk)
13	ARC9000537	6' Rotary Cutter Back Brace (2pk)
14	ARC9000543	Inner Pivot Plate Bushing (2pk) (Gray)
15	ARC9000544	Outer Pivot Plate Bushing (2pk) (Gray)
16	ARC9000538	4' Rotary Cutter Pivot Plate (2pk) (Gray)
16	ARC9000539	5', 6', 7' Rotary Cutter Pivot Plate (2pk) (Gray)
17	ARCRCPPH	Rotary Cutter Pivot Plate Hardware (2pk)
18	ARC9000540	4' Rotary Cutter Lift Arms (2pk) (Gray)
18	ARC9000541	5' & 6' Rotary Cutter Lift Arms (2pk) (Gray)
19	HPC1L	Category 1 Pin

Item Number	Part Number	Description
20	ARC9000545	4' Rotary Cutter Pin Bushing (2pk) (Gray)
20	ARC9000546	5' & 6' Rotary Cutter Pin Bushing (2pk) (Gray)
21	RBRC56MHWH	Rotary Cutter Manual Holder w/ hardware
22	ARCRCBH	Rotary Cutter Blade Holder
23	ARCRCBBWW	Blade Bolt Set (2pk)
24	ARCRCBL4	4' Rotary Cutter Blades (set of 2)
24	ARCRCBL5	5' Rotary Cutter Blades (set of 2)
24	ARCRCBL6	6' Rotary Cutter Blades (set of 2)
25	ARC2000029	Gearbox w/ castle nut & cotter pin
26	ARCPTOBWS	ARC148SP, ARC260SP Shear Pin PTO Shaft Hardware Kit
27	ARCRCGBH	Rotary Cutter Gearbox Hardware (4pk)
28a	ARCRC45A	4' Shear Pin PTO Shaft w/hardware
28a	ARC9000372	5' Shear Pin PTO Shaft w/hardware
28b	ARC9000291	5' & 6' Slip Clutch PTO w/Hardware
29a	I12SP45RCPTO	Implement 1/2 Shear Pin 4' Rotary Cutter PTO
29a	ARC9000374	Implement 1/2 Shear Pin 5' Rotary Cutter PTO
29b	ARC9000293	5' & 6' Slip Clutch Implement 1/2 PTO
30a	T12SP45RCPTO	Tractor 1/2 Shear Pin 4' Rotary Cutter PTO
30a	ARC9000373	Tractor 1/2 Shear Pin 5' Rotary Cutter PTO
30b	ARC9000292	5' & 6' Slip Clutch Tractor 1/2 PTO
Not Shown	ARC2000129	Plastic Shield Locking Collar
Not Shown	ARCPTOGZ	PTO Shaft Grease Zerk w/45 degree bend

PARTS

GEARBOX

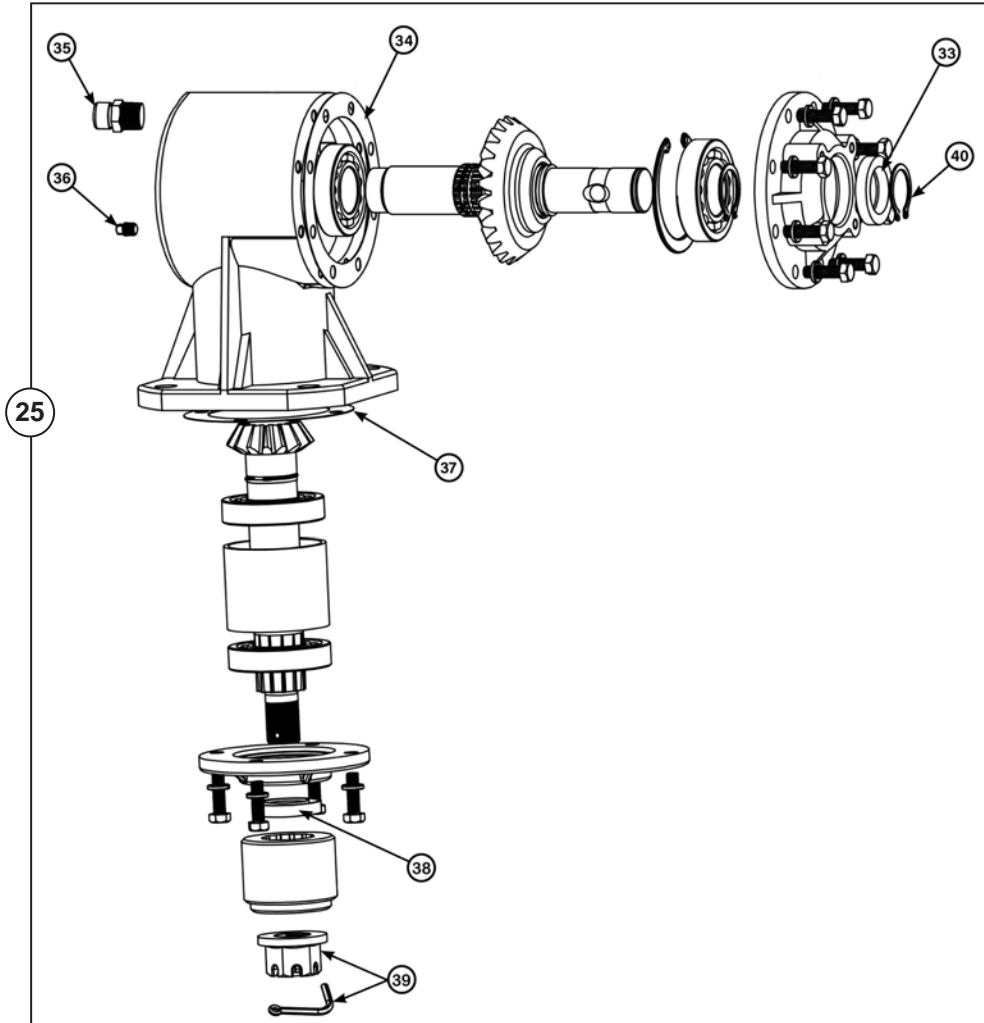

Item Number	Part Number	Description
25	ARC2000029	Gearbox w/ castle nut & cotter pin
33	ARCS-201	Gearbox Input Seal
34	ARCH-R0141	Gearbox Input Shaft Gasket
35	ARCS-502	Gearbox Breather
36	ARCS-503	Gearbox Output Shaft Pipe Plug
37	ARCH-R0144	Gearbox Output Shaft Gasket
38	ARCS-202	Gearbox Output Shaft Seal
39	ARC9000298	Gearbox Castle Nut w/Cotter Key
40	ARCSR	Rotary Cutter Gearbox Snap Ring
41	ARC9000301	Slip Clutch Shield Cone w/Hardware

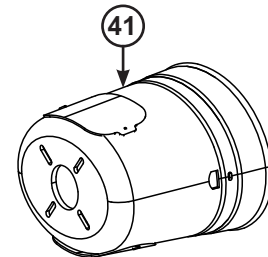

PARTS

OPTIONAL GUARD KITS

Item Number	Part Number	Description
Not Shown	ARC9000148	4' Rotary Cutter Front Rubber Guard Kit (Black)
Not Shown	ARC9000149	5' Rotary Cutter Front Rubber Guard Kit (Black)
Not Shown	ARC9000150	6' Rotary Cutter Front Rubber Guard Kit (Black)
Not Shown	ARC9000151	4' Rotary Cutter Rear Metal Guard Kit (Black)
Not Shown	ARC9000152	5' Rotary Cutter Rear Metal Guard Kit (Black)
Not Shown	ARC9000153	6' Rotary Cutter Rear Metal Guard Kit (Black)
Not Shown	ARC9000154	4' Rotary Cutter Front Rubber & Rear Metal Guard Kit (Black)
Not Shown	ARC9000155	5' Rotary Cutter Front Rubber & Rear Metal Guard Kit (Black)
Not Shown	ARC9000156	6' Rotary Cutter Front Rubber & Rear Metal Guard Kit (Black)
Not Shown	ARC9000589	4' Rotary Cutter Front Chain Guard w/ Hardware (Black)
Not Shown	ARC9000590	4' Rotary Cutter Rear Chain Guard w/ Hardware (Black)
Not Shown	ARC9000591	5' Rotary Cutter Front Chain Guard w/ Hardware (Black)
Not Shown	ARC9000592	5' Rotary Cutter Rear Chain Guard w/ Hardware (Black)
Not Shown	ARC9000593	6' Rotary Cutter Front Chain Guard w/ Hardware (Black)
Not Shown	ARC9000594	6' Rotary Cutter Rear Chain Guard w/ Hardware (Black)
Not Shown	ARC9000596	4' & 5' Rotary Cutter Front Chain Guard Hardware Kit (Service)
Not Shown	ARC9000597	6' Rotary Cutter Front Chain Guard Hardware Kit (Service)
Not Shown	ARC9000598	4', 5', & 6' Rotary Cutter Rear Chain Guard Hardware Kit (Black) (Service)

BOLT TORQUE CHART

Proper torque for American fasteners used on manufactured implement.
Recommended Torque in Foot Pounds (Newton Meters).*

AMERICAN Bolt Head Markings



SAE Grade 2
(No Dashes)



SAE Grade 5
(3 Dashes)

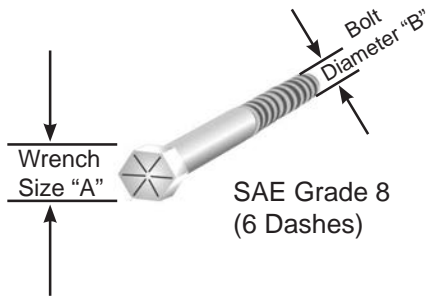

SAE Grade 8
(6 Dashes)

WRENCH SIZE(IN.) "A"	BOLT DIAMETER (IN.) "B" AND THREAD SIZE	SAE GRADE 2	SAE GRADE 5	SAE GRADE 8
7/16	1/4 - 20 UNC	6 (7)	8 (11)	12 (16)
7/16	1/4 - 24 UNF	6 (8)	10 (13)	14 (18)
1/2	5/16 - 18 UNC	11 (15)	17 (23)	25 (33)
1/2	5/16 - 24 UNF	13 (17)	19 (26)	27 (37)
9/16	3/8 - 16 UNC	20 (27)	31 (42)	44 (60)
9/16	3/8 - 24 UNF	23 (31)	35 (47)	49 (66)
5/8	7/16 - 14 UNC	32 (43)	49 (66)	70 (95)
5/8	7/16 - 20 UNF	36 (49)	55 (75)	78 (106)
3/4	1/2 - 13 UNC	49 (66)	76 (103)	106 (144)
3/4	1/2 - 20 UNF	55 (75)	85 (115)	120 (163)
7/8	9/16 - 12 UNC	70 (95)	109 (148)	153 (207)
7/8	9/16 - 18 UNF	79 (107)	122 (165)	172 (233)
15/16	5/8 - 11 UNC	97 (131)	150 (203)	212 (287)
15/16	5/8 - 18 UNF	110 (149)	170 (230)	240 (325)
1-1/8	3/4 - 10 UNC	144 (195)	266 (360)	376 (509)
1-1/8	3/4 - 16 UNF	192 (260)	297 (406)	420 (569)
1-5/16	7/8 - 9 UNC	166 (225)	430 (583)	606 (821)
1-5/16	7/8 - 14 UNF	184 (249)	474 (642)	668 (905)
1-1/2	1 - 8 UNC	250 (339)	644 (873)	909 (1232)
1-1/2	1 - 12 UNF	274 (371)	705 (955)	995 (1348)
1-1/2	1 - 14 UNF	280 (379)	721 (977)	1019 (1381)
1-11/16	1-1/8 - 7 UNC	354 (480)	795 (1077)	1288 (1745)
1-11/16	1-1/8 - 12 UNF	397 (538)	890 (1206)	1444 (1957)
1-7/8	1-1/4 - 7 UNC	500 (678)	1120 (1518)	1817 (2462)
1-7/8	1-1/4 - 12 UNF	553 (749)	1241 (1682)	2013 (2728)
2-1/16	1-3/8 - 6 UNC	655 (887)	1470 (1992)	2382 (3228)
2-1/16	1-3/8 - 12 UNF	746 (1011)	1672 (2266)	2712 (3675)
2-1/4	1-1/2 - 6 UNC	870 (1179)	1950 (2642)	3161 (4283)
2-1/4	1-1/2 - 12 UNF	979 (1327)	2194 (2973)	3557 (4820)

BOLT TORQUE CHART

Proper torque for metric fasteners used on manufacturer implement.
Recommended Torque in Foot Pounds (Newton Meters).*

METRIC

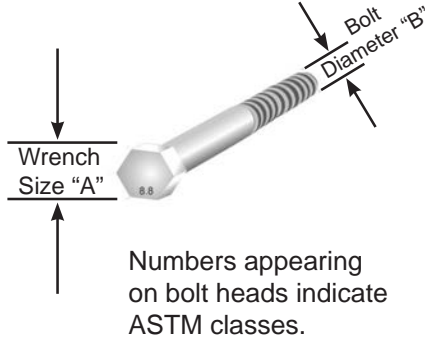

WRENCH SIZE (mm) "A"	BOLT DIA. (mm) "B"	ASTM 4.6	ASTM 8.8	ASTM 9.8	ASTM 10.9
8	5	1.8 (2.4)		5.1 (6.9)	6.5 (8.8)
10	6	3 (4)		8.7 (12)	11.1 (15)
13	8	7.3 (10)		21.1 (29)	27 (37)
16	10	14.5 (20)		42 (57)	53 (72)
18	12	25 (34)	74 (100)	73 (99)	93 (126)
21	14	40 (54)	118 (160)	116 (157)	148 (201)
24	16	62 (84)	167 (226)	181 (245)	230 (312)
30	20	122 (165)	325 (440)		449 (608)
33	22		443 (600)		611 (828)
36	24	211 (286)	563 (763)		778 (1054)
31	27		821 (1112)		1138 (1542)
46	30	418 (566)	1119 (1516)		1547 (2096)

*Use 75% of the specified torque value for plated fasteners. Use 85% of the specified torque values for lubricated fasteners.

WARRANTY

Limited Warranty

Belco Resources Equipment warrants to the original purchaser of any new piece of machinery from Belco Resources Equipment, purchased from an authorized Belco Resources Equipment dealer, that the equipment be free from defects in material and workmanship for a period of one (1) year for non-commercial, state, and municipalities' use, ninety (90) days for commercial use from date of retail sale. Warranty for rental purposes is thirty (30) days. The obligation of Belco Resources Equipment to the purchaser under this warranty is limited to the repair or replacement of defective parts.

Replacement or repair parts installed in the equipment covered by this limited warranty are warranted for ninety (90) days from the date of purchase of such part or to the expiration of the applicable new equipment warranty period, whichever occurs later. Warranted parts shall be provided at no cost to the user at an authorized Belco Resources Equipment dealer during regular working hours. Belco Resources Equipment reserves the right to inspect any equipment or parts, which are claimed to have been defective in material or workmanship.

This limited warranty does not apply to and excludes wear items such as shear pins, tires, tubes, knives, blades or other wear items. Oil or grease is not covered by this warranty.

All obligations of Belco Resources Equipment under this limited warranty shall be terminated if:

Proper service is not performed on the machine.

The machine is modified or altered in any way.

The machine is being used or has been used for purposes other than those for which the machine was intended.

Disclaimer of Implied Warranties & Consequential Damages

Belco Resources Equipment obligation under this limited warranty, to the extent allowed by law, is in lieu of all warranties, implied or expressed, including implied warranties of merchantability and fitness for a particular purpose and any liability for incidental and consequential damages with respect to the sale or use of the items warranted. Such incidental and consequential damages shall include but not be limited to: transportation charges other than normal freight charges; cost of installation other than cost approved by Belco Resources Equipment; duty taxes; charges for normal service or adjustment; loss of crops or any other loss of income; rental of substitute equipment, expenses due to loss, damage, detention or delay in the delivery.

Registration

The online Warranty Registration must be completed in order to qualify for coverage on this Limited Warranty. Visit br-equipment.com, click on "Warranty Registration" and completely fill out the for to register the new piece of equipment.

WARRANTY

Additional Information

Contact your authorized dealer for complete warranty information and assistance with warranty claims. Retain original sales receipt, and record the model number, serial number, and the date of purchase in the spaces provided below. This information will be helpful to the dealer if parts or service are required.

Warranty Claim Information

Dealer Name.....

Dealer Address.....

Dealer Phone.....

Dealer Email.....

Purchase Date.....

Model Number.....

Serial Number/UPC.....



401 Jeffreys Road
Rocky Mount, NC 27804
www.tarrivermfg.com

Tel: 252-822-7140
Fax: 252-787-5855
Sales@tarrivermfg.com