

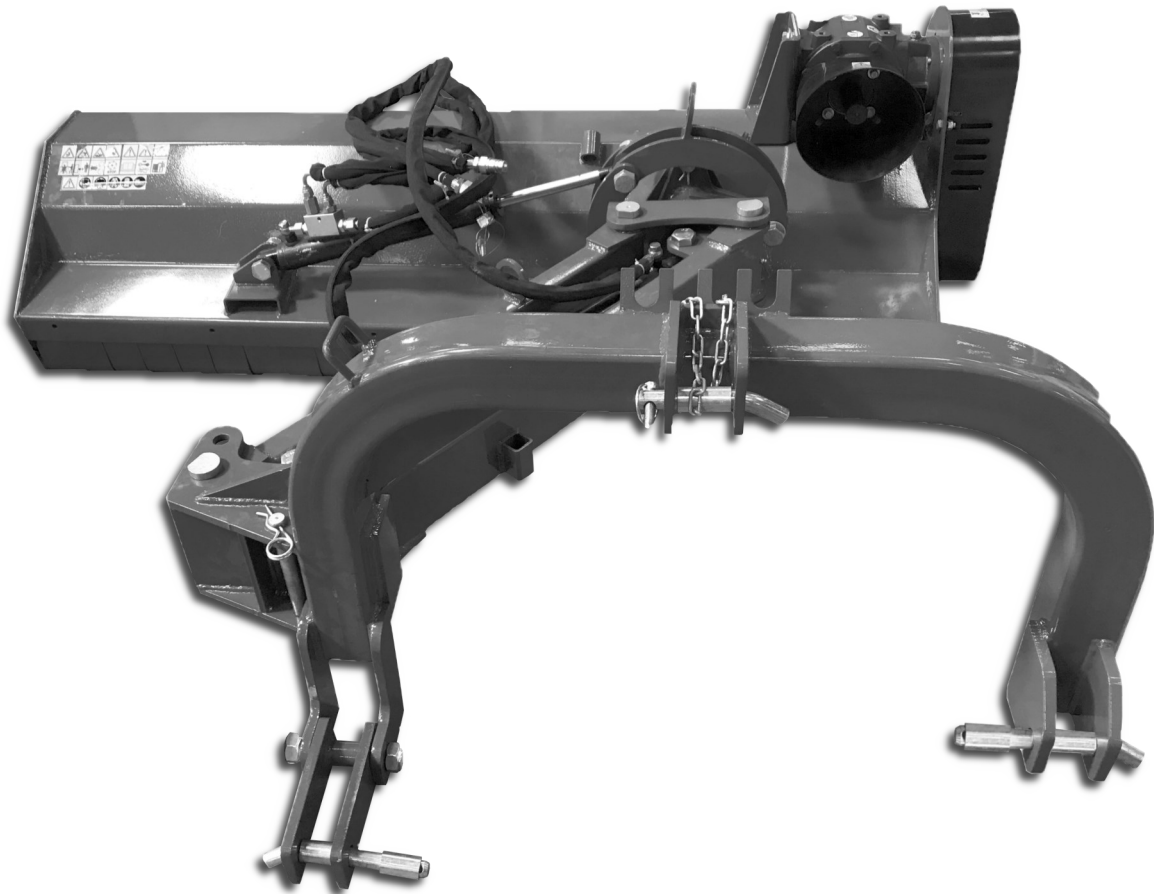

Ditchbank Mower

TRDB Series



Operator's Manual

Page left blank intentionally



TO THE DEALER:

Assembly and proper installation of this product is the responsibility of the Tar River dealer. Read manual instructions and safety rules. Make sure all items on the Dealer's Pre-Delivery and Delivery Check Lists in the Owner's/Operator's Manual are completed before releasing equipment to the owner.

TO THE OWNER:

Read this manual before operating your Tar River equipment. The information presented will prepare you to do a better and safer job. Keep this manual handy for ready reference. Require all operators to read this manual carefully and become acquainted with all the adjustment and operating procedures before attempting to operate. Replacement manuals can be obtained from your selling dealer. The equipment you have purchased has been carefully engineered and manufactured to provide dependable and satisfactory use. Like all mechanical products, it will require cleaning and upkeep. Lubricate the unit as specified. Observe all safety information in this manual and safety decals on the equipment. For service, your authorized Tar River dealer has trained mechanics, genuine Tar River service parts, and the necessary tools and equipment to handle all your needs. Use only genuine Tar River service parts. Substitute parts will void the warranty and may not meet standards required for safe and satisfactory operation.

Record your implement model and serial number in the space provide below. Your dealer will need this information to give you prompt, efficient service.

Model Number: _____

Serial Number: _____

Date Purchased: _____

Table of Contents

Introduction	5
Technical Specifications	5
Safety	6
Safety Signal Words	6
General Safety Guidelines	7
Safety Decal Care	7-8
Before Operation	9
During Operation	10
Highway And Transport Operations	11-12
Assembly	13-14
Operating Instructions.....	15-16
Maintenance	17
Set-up / Troubleshooting Guide.....	18-19
Torque Specifications	21
Parts Breakdown	23-49
Warranty	50

Introduction

Thank you for purchasing your Ditchbank Mower. The Tar River hydraulic offset pivoting Ditchbank mower is the ideal machine to maintain ditches or embankments around your property. Hook up to the standard 3 point like a normal flail mower that is pulled directly behind the tractor. When in the full operating position the **TRDB-053, TRDB-061** will mow 90° up and 30° down, while the **TRDB-069** will mow 90° up and 35° down. All models come standard with heavy hammer knives and a perfectly balanced rotor for a smooth operation.

Technical Specifications

- Cat. 1 & 2 hitch
- Power coat paint
- Heavy cast hammer knives
- 3 & 4 belt configurations
- Adjustable height control rear roller

	TRDB-053	TRDB-061	TRDB-069
Working width	53"	61"	69"
Cutting angle	90° up & 30° down	90° up & 30° down	90° up & 35° down
Minimum HP	30 HP	35 HP	45 HP
Weight	664 lbs.	697 lbs.	1002 lbs.

Important Safety Information

Safety

It is important that you read the entire manual and to become familiar with this product before you begin using it. This product is designed for certain applications only. The manufacturer cannot be responsible for issues arising from modification. We strongly recommend this product not be modified and /or used for any application other than that for which it is designed. If you have any questions relative to a particular application, DO NOT use the product until you have first contacted us to determine if it can or should be performed on the product.

Read and understand this manual and all safety signs before operating and maintaining . Review the safety instructions and precautions annually.

Safety Signal Words

TAKE NOTE! This safety alert symbol found though out this manual is used to call you attention to instructions involving you personal safety and the safety of others. Failure to follow these instructions can result in injury or death.



**This symbol means:
Attention!
Become alert!
Your safety is involved!**

Note the use of the signal words, **DANGER, WARNING and CAUTION** with the safety messages. The appropriate signal word for each has been selected using the following guidelines:



DANGER: Indicates an imminently hazardous situation that, if not avoided, will result in death or serious injury. This signal word is to be limited to the most extreme situations typically for machine components which, for functional purposes, cannot be guarded.



WARNING: Indicates a potentially hazardous situation that, if not avoided, could result in death or serious injury, and includes hazards that are exposed when guards are removed. It may also be used to alert against unsafe practices.



CAUTION: Indicates a potentially hazardous situation that, if not avoided, may result in minor or moderate injury. It may also be used to alert against unsafe practices.

Important Safety Information

General Safety Guidelines

Safety of the operator is one of the main concerns in designing and developing a new piece of equipment. Designers and manufacturers build in as many safety features as possible. However, every year many accidents occur which could have been avoided by a few seconds of thought and a more careful approach to handling equipment. You, the operator, can avoid many accidents by observing the following precautions in this section. To avoid personal injury, study the following precautions and insist those working with you, or for you, follow them.

Replace any **DANGER, WARNING, CAUTION** or instruction safety decal that is not readable or is missing. Location of such decals are indicated in this manual. Do not attempt to operate this equipment under the influence of drugs or alcohol.

Review the safety instructions with all users annually.

This equipment is dangerous to children and persons unfamiliar with its operation. The operator should be a responsible adult familiar with farm machinery and trained in this equipment's operations. **Do not allow persons to operate or assemble this unit until they have read this manual and have developed a thorough understanding of the safety precautions and of how it works.**

To prevent injury of death, use a tractor equipped with a Roll Over Protection System (ROPS). Do not paint over, remove or deface any signs or warning decals on your equipment. Observe all safety signs and practice the instructions on them.

Never exceed the limits of a piece of machinery. If its ability to do a job, or to do so safely, is in question - **Don't try it!**



Safety Decal Care

- Keep safety signs clean and legible at all times.
- Replace safety signs that are missing or have become illegible.
- Replaced parts that displayed a safety sign should also display the current safety sign
- Do not paint over, remove, or deface any safety signs or warning signs on your equipment.
- Observe all safety signs and practice the instruction on them.
- Safety signs are available from your Distributor or Dealer Parts Department or the factory.

Important Safety Information

How to install Safety Signs:

- Be sure that the installation area is clean and dry.
- Decide on the exact position before you remove the backing paper.
- Remove the smallest portion of the split backing paper.
- Align the decal over the specified area and carefully press the small portion with the exposed sticky backing in place.
- Slowly peel back the remaining paper and carefully smooth the remaining portion of the decal in place.
- Small air pockets can be pierced with a pin and smoothed out using the piece of decal backing paper.



Important Safety Information



Before Operation

- Carefully study and understand this manual.
- Do not wear loose-fitting clothing, which may catch in moving parts.
- Always wear protective clothing and substantial shoes.
- Assure that all tires are inflated evenly.
- Give the unit a visual inspection for any loose bolts, worn parts or cracked welds, and make necessary repairs. Follow the maintenance safety instructions included with this manual.
- Be sure that there are no tools lying on or in the equipment.
- Do not use the unit until you are sure that the area is clear, especially of children and animals.
- Don't hurry the learning process or take the unit for granted. Ease into it and become familiar with your new equipment.
- Practice operation of your equipment and its attachments. Completely familiarize yourself and other operators with its operation before using.
- Use a tractor equipped with a Roll Over Protection System (ROPS) and fasten your seat belt prior to starting engine.
- The manufacturer does not recommend usage of tractor with ROPS removed.
- Move tractor wheels to the widest recommended settings to increase stability.
- Securely attach to towing unit. Use a high strength, appropriately sized hitch pin with a mechanical retainer and attach safety chain.
- Do not allow anyone to stand between the tongue or hitch and the towing vehicle when backing up to the equipment.
- Do not use the unit until you are sure that the area is clear, especially of children and animals.

Important Safety Information



During Operation

- Children should not be allowed on the machine.
- Clear the area of small children and bystanders before moving the machine.
- If using a towing unit, securely attach machine by using a hardened 3/4" pin, a metal retainer, and safety chains if required. Shift towing unit to a lower gear before going down steep downgrades, thus using the engine as a retarding force. Keep towing vehicle in gear at all times. Slow down for corners and rough terrain.
- Make sure you are in compliance with all local and state regulations regarding transporting equipment on public roads and highways. Lights and slow moving signs must be clean and visible by overtaking or oncoming traffic when machine is transported.
- Beware of bystanders, **particularly children!** Always look around to make sure that it is safe to start the engine of the towing vehicle or move the unit. This is particularly important with higher noise levels and quiet cabs, as you may not hear people shouting.
- **NO PASSENGERS ALLOWED!** Do not carry passengers anywhere on, or in, the tractor or equipment, except as required for operation.
- Keep hands and clothing clear of moving parts.
- Do not clean, lubricate or adjust your equipment while it is moving.
- When halting operation, even periodically, set the tractor or towing vehicle brakes, disengage the PTO, shut off the engine and **remove the ignition key.**
- Be especially observant of the operating area and terrain. Watch for holes, rocks or hidden hazards. Always inspect the area prior to operation.
- **DO NOT** operate near the edge of drop-offs or banks.
- **DO NOT** operate on steep slopes as overturns may result.
- Operate up and down (not across) intermediate slopes. Avoid sudden starts and stops.

Important Safety Information



Highway and Transport Operations

- Adopt safe driving practices.
- Keep the brake pedals latched together at all times. **Never use independent braking with machine in tow as loss of control and/or upset of unit can result.**
- Always drive at a safe speed relative to local conditions and ensure that your speed is low enough for an emergency stop to be safe and secure. Keep speed at a minimum.
- Reduce speed prior to turns to avoid the risk of overturning.
- Avoid sudden uphill turns on steep slopes.
- Always keep the tractor or towing vehicle in gear to provide engine braking when going downhill. Do not coast.
- Do not drink and drive!
- Comply with state and local laws governing highway safety and movement of farm machinery on public roads.
- Use approved accessory lighting, flags and necessary warning devices to protect operators of other vehicles on the highway during daylight and nighttime transport. Various safety lights and devices are available from your dealer.
- The use of flashing amber lights is acceptable in most localities. However, some localities prohibit their use. Local laws should be checked for all highway and marking requirements.
- When driving the tractor and equipment on the road or highway under 40 kph (20 mph) at night or during the day, use the amber warning lights and a slow moving vehicle (SMV) identification emblem.
- Plan your route to avoid heavy traffic.
- Be a safe and courteous driver. Always yield to oncoming traffic in all situations, including narrow bridges, intersections, etc.
- Be observant of bridge loading ratings. Do not cross bridges rated at lower than the gross weight at which you are operating.
- Watch for obstructions overhead and to the side while transporting.
- Always operate in a position to provide maximum visibility at all times. Make allowances for increased length and weight of the equipment when making turns, stopping the unit, etc.
- Pick the most level route when transporting across fields. Avoid the edges of ditches or gullies and steep hillsides.
- Be extra careful when working in inclines.

Important Safety Information



Highway and Transport Operations

- Maneuver the tractor or towing vehicle at safe speeds.
- Avoid overhead wires or other obstacles. Contact with overhead lines could cause serious injury or death.
- Avoid loose fill, rocks and holes, they can be dangerous for equipment operation or movement.
- Allow for unit length when making turns,
- Operate the towing vehicle from the operator's seat only.
- Never stand alongside of unit with engine running or attempt to start engine and/or operate machine while standing alongside of unit.
- Never leave running equipment attachments unattended.
- As a precaution, always recheck the hardware on equipment following every 100 hours of operation. Correct all problems. Follow the maintenance safety procedures.

Assembly

- Carefully remove all parts from the crate.
- Assemble the pivot arm on the mower frame.
- Assemble the pivot arms to the “A Frame”.
- Assemble hydraulic hoses and cylinder.
- Attach front and rear protection bars.

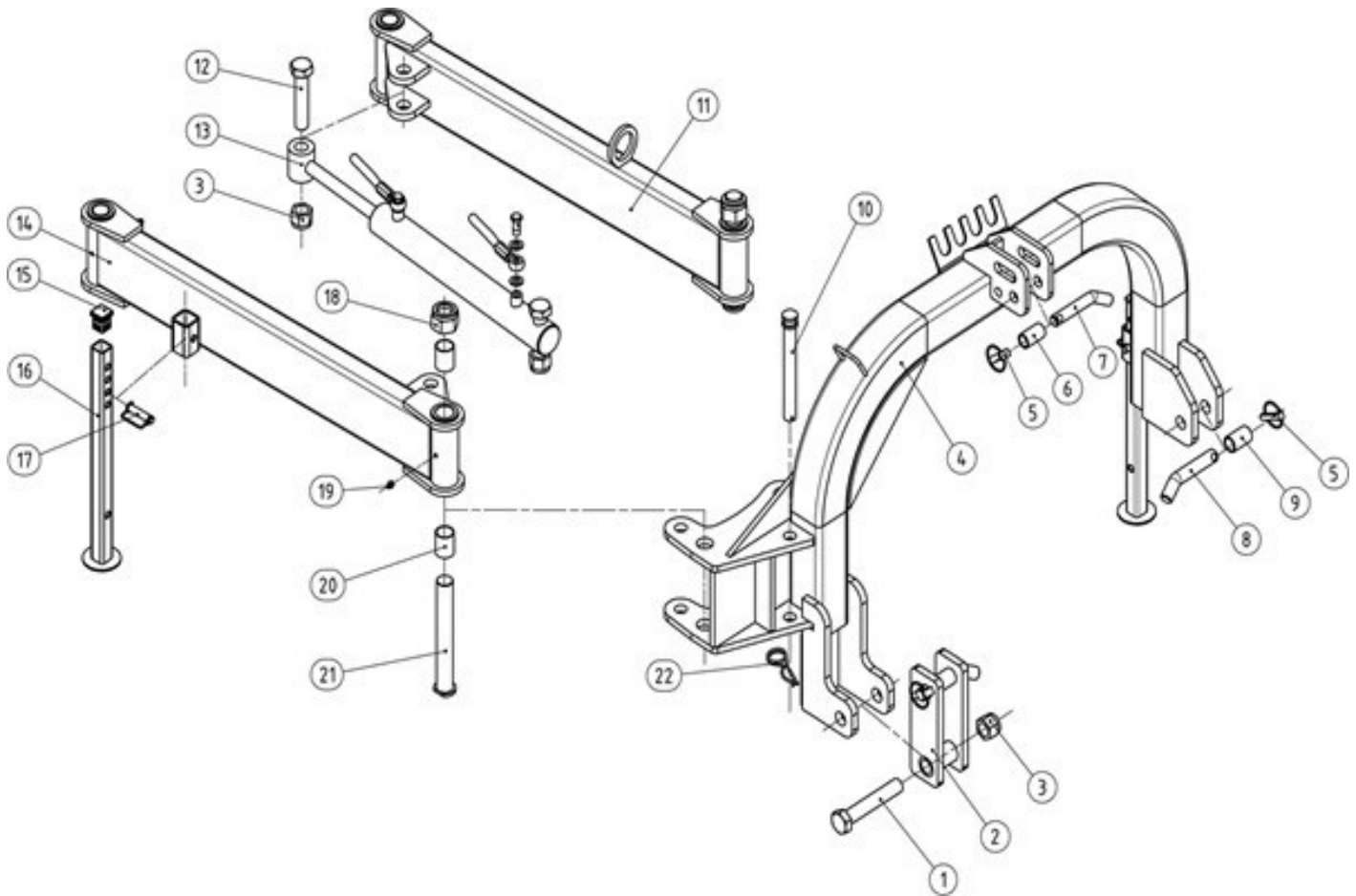

Assembly

Attaching the PTO shaft:

Before installing the PTO shaft make sure that the RPM rating and the direction of rotation match those of the tractor. Carefully read the PTO shaft and tractor instructions. Before operation, make sure that the guards are installed on the power take off of the tractor and PTO shaft. Make sure that they cover the PTO shaft throughout its length. Note: The PTO shaft may be too long and require shortening. See “**Shortening a PTO driveline**” below.

Press the locking pin on the PTO yoke and slide yoke on to the PTO of the tractor until the pin seats. Pull on PTO shaft to make certain it is locked in place. Repeat the procedure for the machine end. Attach the PTO cover’s safety chains to a stationary part of the tractor. Leave some slack in the chain to accommodate movement.

Shortening a PTO driveline:

1. With the machine attached to the tractor’s 3-point hitch, and the PTO shaft not installed, separate the PTO shaft. Attach the machine end to the machine and the other end to the tractor PTO input shaft.
2. Raise the machine by using the tractor’s hydraulic 3-point hitch to its maximum lift height.
3. Hold the half shafts next to each other and mark them so each end is approximately 1/2” from hitting the end of the telescopic profiles.
4. Shorten the inner and outer guard tubes equally.
5. Shorten the inner and outer profiles by the same length as the guard tubes. Using a rattail file, round off all sharp edges and burrs. Grease the telescopic profile generously before reassembling.

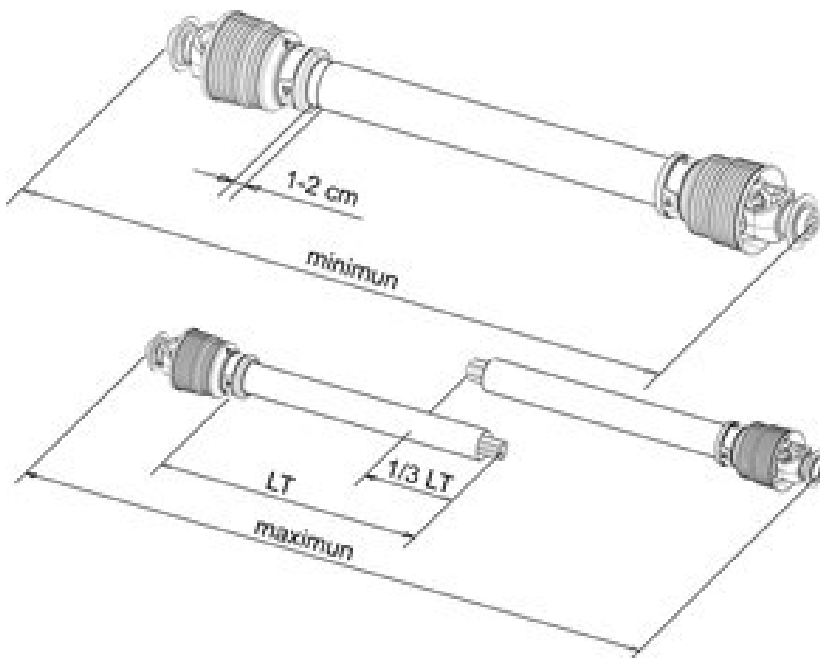

When fully extended, the tubes must overlap by at least 1/3 of the length of the pipes (LT). When retracted, the min. acceptable clearance is 1-2 cm (3/8”-3/4”)

Scan the QR code below for more detailed information on PTO installation.



Operating Instructions

- Check oil level in the center gearbox.
- Check oil level in the drive tube.
- Check belt tension.
- Check rotor bearings on both sides.
- Check the PTO length (See PTO section).

Pivot pin locking position

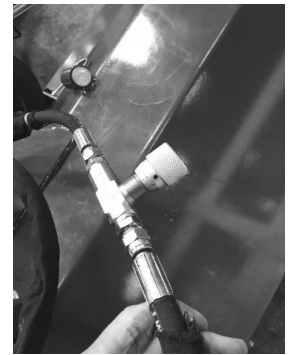
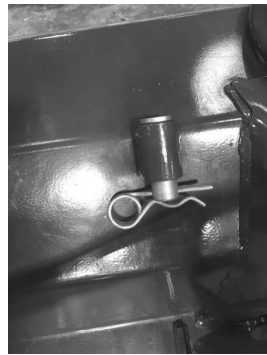

Cutting height adjustment

The cutting height of the equipment depends on the position of the rear roller. Both sides are set at the same height.

To adjust the cutting height on the flail mowers, loosen the pivot bolt (do not remove) and reposition the bolts holding the roller to the desired height.

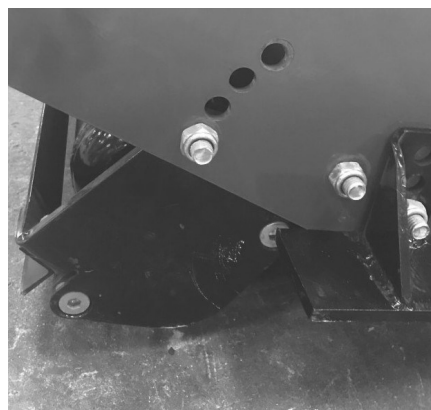

Operating Instructions

Belt tension adjustment

Note: These instructions are for the previous production models of the TRDB. Check your serial number prior to tightening the belts. If your model does not look like the images below, proceed to the next two page(s) for current production.

It is necessary to adjust the belt tension as the belts stretch. Correct belt tensioning ensures that the machine works properly.

Note: It is necessary to remove the belt shield on this version of the TRDB.

To adjust belt tension:

- Remove the belt shield.
-  • Loosen but do not remove hardware holding the gearbox support in place.
- Tighten belts by turning the nut on the belt adjustment plate.
- Retighten the gearbox support hardware and replace shield.

Danger! Always replace shields prior to operating the machine. Moving parts can cause serious injury or death.



Remove belt shield

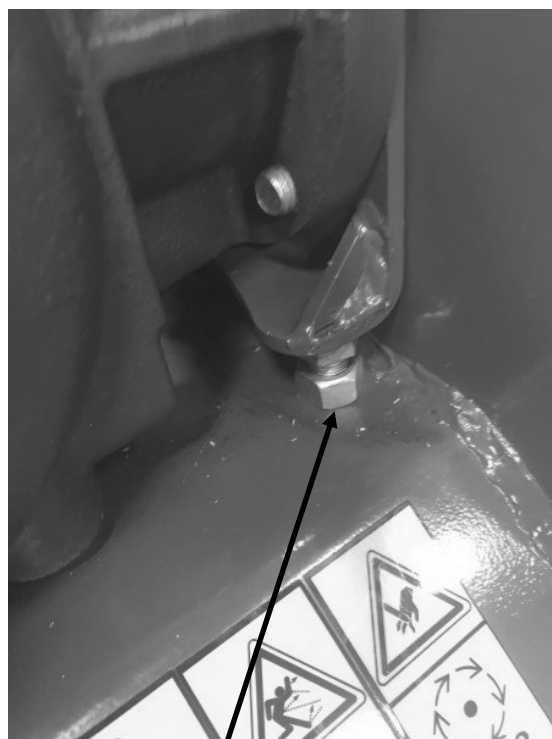

Adjustment nut

Operating Instructions

Belt tension adjustment for: TRDB-053, Serial #41100 and up TRDB-061, Serial #42200 and up

It is necessary to adjust belt tension as the belts stretch. Correct belt tensioning ensures that the machine works properly.

Note: It is not necessary to remove the belt shield on this version of the TRDB.

To adjust belts tension:

- Loosen (3) socket head cap screws “A”,
- Loosen (2) hex nuts, “B”,
- Tighten belts by turning the nut “C” on the belt adjustment plate.
- When belts are properly adjusted, tighten jam nut “D”.
- Retighten socket head cap screws “A” and hex nuts “B”.

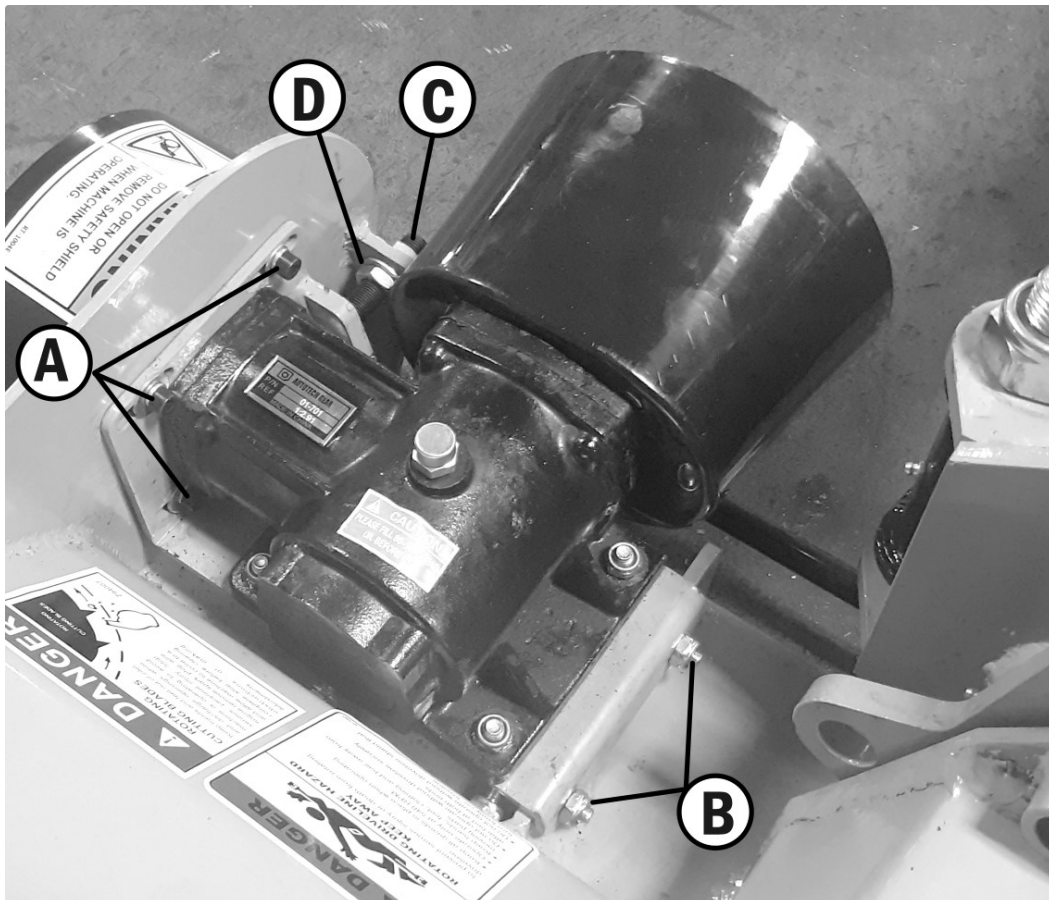

Operating Instructions

Belt tension adjustment for: TRDB-069, Serial #51200 and up

It is necessary to adjust the belt tension as the belts stretch. Correct belt tensioning ensures that the machine works properly.

Note: It is not necessary to remove the belt shield on this version of the TRDB.

To adjust belt tension:

- Loosen (4) socket head cap screws “A”.
- Loosen (4) hex nuts, “B”.
- Tighten belts by turning two hex bolts “C” (1 in front & 1 in back) on the belt adjustment plate. The rear bolt is shown. Be sure to tighten the front bolt as well.
- When belts are properly adjusted, re-tighten (4) socket head cap screws “A” and (4) hex bolts “B”.

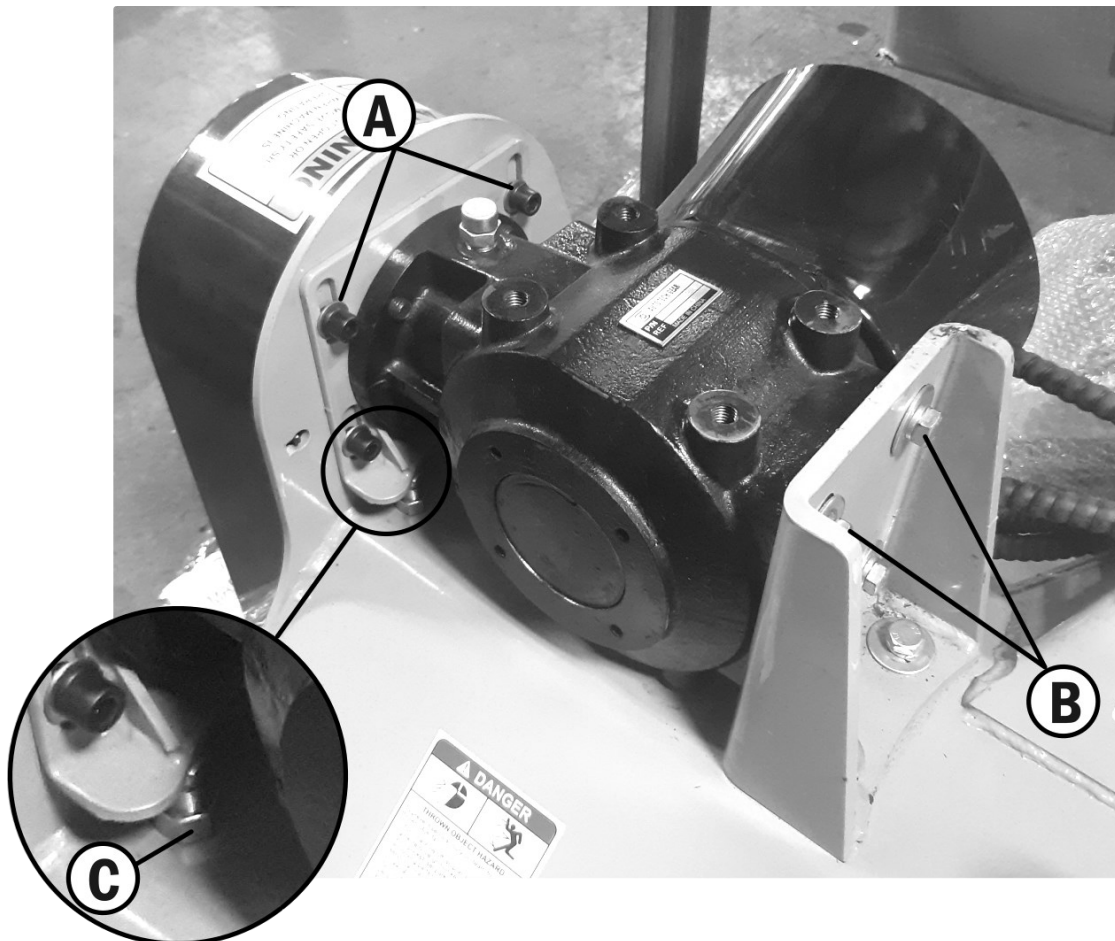

Operating Instructions

Maintenance

Maintenance is crucial for the working life and efficiency of any agricultural equipment. If the equipment is properly maintained and operated, a long working life and operator safety are assured.

The maintenance intervals indicated in this manual are provided as a reference and are related to normal working conditions. Changes may occur depending on the type of activities, environmental dust, seasonal factors, etc.

Before beginning:

Check oil level in the center gearbox and the drive tube. Use 80/90 wt Gear Oil in gearbox. Grease rotor bearings if needed.

After 8 hours:

Check oil level in the center gearbox.
Check hardware for tightness.

After 30 hours:

Check hardware for tightness.
Check belt tension and wear.

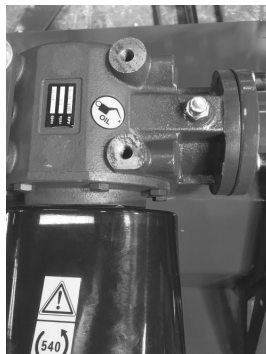

Center Gearbox

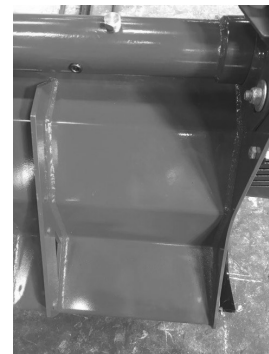

Drive Tube



Left Rotor Bearing



Right Rotor Bearing

TRDB Flail Mower Set-up/Troubleshooting Guide

Before using your new TRDB flail mower there are several things to know and understand about its function and operation.

1. Check for correct belt tightness and adjust accordingly to achieve 10mm max belt deflection.

- Remove the belt guard.
- Loosen 4 bolts behind pulley.
- Loosen gearbox support plate bolts.
- Adjust belt tension bolt to desired amount.
- Verify the pulleys are still in alignment.
- Retighten 4 bolts behind drive pulley.
- Retighten the gearbox support plate bolts.
- Replace belt shield.

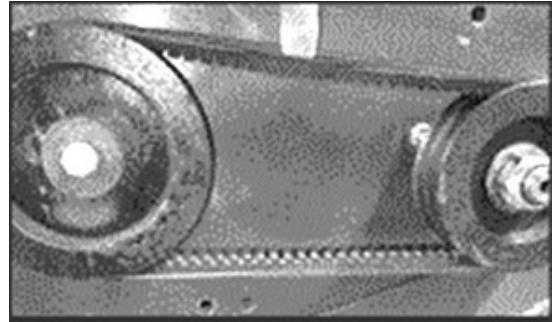

2. Check the gearbox for the appropriate amount of gear oil (Use 80w/90 gear oil) DO NOT OVERFILL. Gearbox should be approximately half full.
3. Check hydraulic hose fittings for tightness and verify no leaks.
4. Verify hydraulic cylinders have been purged of air and operate with a full range of motion.
(Adjust hydraulic flow restrictors to slow the speed at which the hydraulic cylinders open)
5. Apply grease to all grease fittings on the mower. (Rotor, all Pins, Frame Pivot)
6. If mowing in tall grass keep debris (grass, twine, plastic, barbed wire, etc.) or long grasses from becoming entangled around the rotor keeping the mower from rotating freely.
7. Drive belts are used on flail mowers in the place of a shear bolt or slip clutch as the safety device. The belts will slip if the machine overcomes the grip of the belts. In most cases if the belts slip it is due to lack of adjustment, wear, grass or debris buildup or improper mower use.
8. Please ensure the side plate that the gear box is attached to is straight. The plate can become bent when the bolts are not loosened behind the pulley to adjust the belt tension. This will not only cause premature belt wear, it also results in the pulleys being misaligned.
9. **Flail mowers are not intended to be used like a forestry mulcher!!!**

TRDB Flail Mower Set-up/Troubleshooting Guide

Troubleshooting Guide

Issue	Cause	Solution
Oil leaking around hoses	Loose fittings	Tighten Loose Fittings
Oil Leaking around Gearbox	Overfull	Drain oil. Fill up ½ way.
	Bolts Loose on Gearbox	Tighten loose bolts.
	Incorrect Breather cap	Replace Breather cap
Premature Belt wear	Improper belt tension	Tighten belts.
	Belt Slippage due to grass build up	Remove excessive grass buildup around rotor.
Belt smoking	Improper belt tension	Tighten belts.
	Belt Slippage due to grass build up	Remove excessive grass buildup around rotor
Belts running off	Pulleys out of alignment	Check Pulley alignment gearbox
	Bent side plate/gearbox mount	bolts not loosened during belt tensioning.
Hydraulic cylinders will not travel full range of motion	Air must be bled from both sides of Hyd. cylinders	Start with effected cylinder. Loosen fitting to allow air to escape.
Damaged PTO shaft	Driveline angle too severe	Adjust 3 pt. hitch to remove excessive movement.
	Do Not bottom out PTO while raising mower	Correctly “size” PTO
Cutting into dirt	Mower not level	Level cutter head.
		Adjust rear roller to lower float setting.

Torque Specifications

Torque Specifications for Common Bolt Sizes															
Inches		Bolt Head Identification						Metric		Bolt Head Identification					
										5.8		8.8		10.9	
Bolt size (inches)	Thread pitch	Grade 2		Grade 5		Grade 8		Class 5.8		Class 8.8		Class 10.9			
		N.m	ft-lb	N.m	ft-lb	N.m	ft-lb	N.m	ft-lb	N.m	ft-lb	N.m	ft-lb		
1/4"	20	7	5	11	8	16	12	M5	0.08	4	3	6	4	9	7
1/4"	28	8	6	13	10	19	14	M6	1	6	4	10	7	15	11
5/16"	18	15	11	24	17	33	25	M8	1.25	16	12	25	18	36	27
5/16"	24	17	13	26	19	37	27	M8	1	17	13	26	19	38	28
3/8"	16	27	20	42	31	59	44	M10	1.5	31	23	48	35	71	52
3/8"	24	31	23	47	35	67	49	M10	1.25	33	24	51	38	75	55
7/16"	14	43	32	67	49	95	70	M10	1	35	26	53	39	78	58
7/16"	20	48	36	75	55	106	78	M12	1.75	54	40	84	62	123	91
1/2"	13	66	48	102	75	144	106	M12	1.5	56	41	87	64	128	94
1/2"	20	75	55	115	85	163	120	M12	1.25	59	44	90	66	133	98
9/16"	12	95	70	147	109	208	154	M14	2	84	62	133	98	195	144
9/16"	18	106	79	164	121	232	171	M14	1.5	94	69	142	105	209	154
5/8"	11	132	97	203	150	287	212	M16	2	131	97	206	152	302	223
5/8"	18	149	110	230	170	325	240	M16	1.5	141	104	218	161	320	236
3/4"	10	233	172	361	266	509	376	M18	2.5	181	133	295	218	421	310
3/4"	16	261	192	403	297	569	420	M18	2	196	145	311	229	443	327
7/8"	9	226	167	582	430	822	606	M18	1.5	203	150	327	241	465	343
7/8"	14	249	184	642	473	906	668	M20	2.5	256	189	415	306	592	437
1"	8	339	250	873	644	1232	909	M20	1.5	288	212	454	335	646	476
1"	12	371	273	955	704	1348	995	M22	2.5	344	254	567	418	807	595
1-1/8"	7	480	354	1077	794	1746	1288	M22	1.5	381	281	613	452	873	644
1-1/8"	12	539	397	1208	891	1958	1445	M24	3	444	327	714	526	1017	750
1-1/4"	7	677	500	1519	1120	2463	1817	M24	2	488	360	769	567	1095	808
1-1/4"	12	750	553	1682	1241	2728	2012	M27	3	656	484	1050	774	1496	1103
1-3/8"	6	888	655	1992	1469	3230	2382	M27	2	719	530	1119	825	1594	1176
1-3/8"	12	1011	746	2268	1673	3677	2712	M30	3.5	906	668	1420	1047	2033	1499
1-1/2"	6	1179	869	2643	1949	4286	3161	M30	2	1000	738	1600	1180	2250	1659
1-1/2"	12	1326	978	2974	2194	4823	3557	M36	4	1534	1131	2482	1830	3535	2607

Notes:

This chart is an approximate estimate of torque values.

Always tighten hardware to these values unless a different torque value or tightening procedure is listed for a specific application.

Fasteners must always be replaced with the same grade as specified in the manual.

Always use the proper tool for tightening hardware: SAE for SAE hardware and Metric for Metric hardware.

Make sure that fastener threads are clean and that you properly start thread engagement.



Ditchbank Mower

TRDB Series

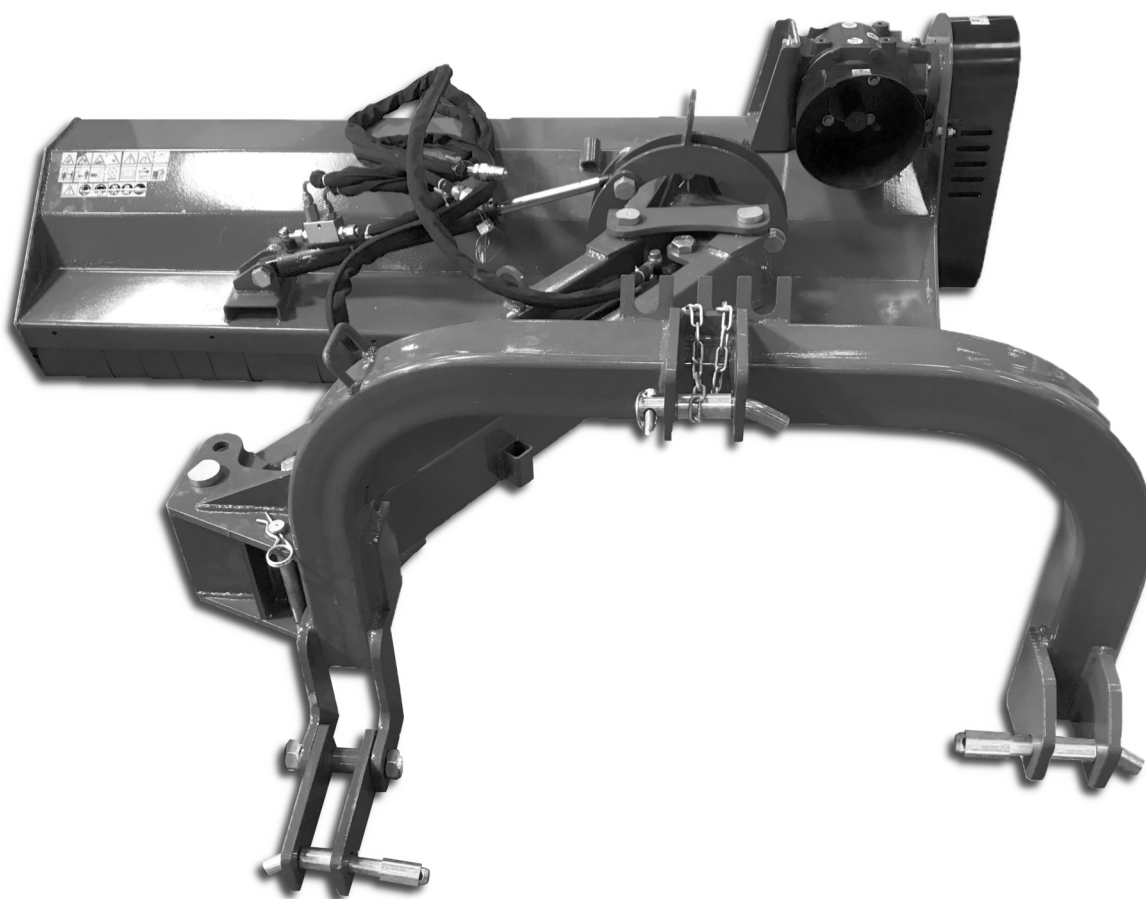

Parts Manual

TRDB-053, TRDB-061 Assembly

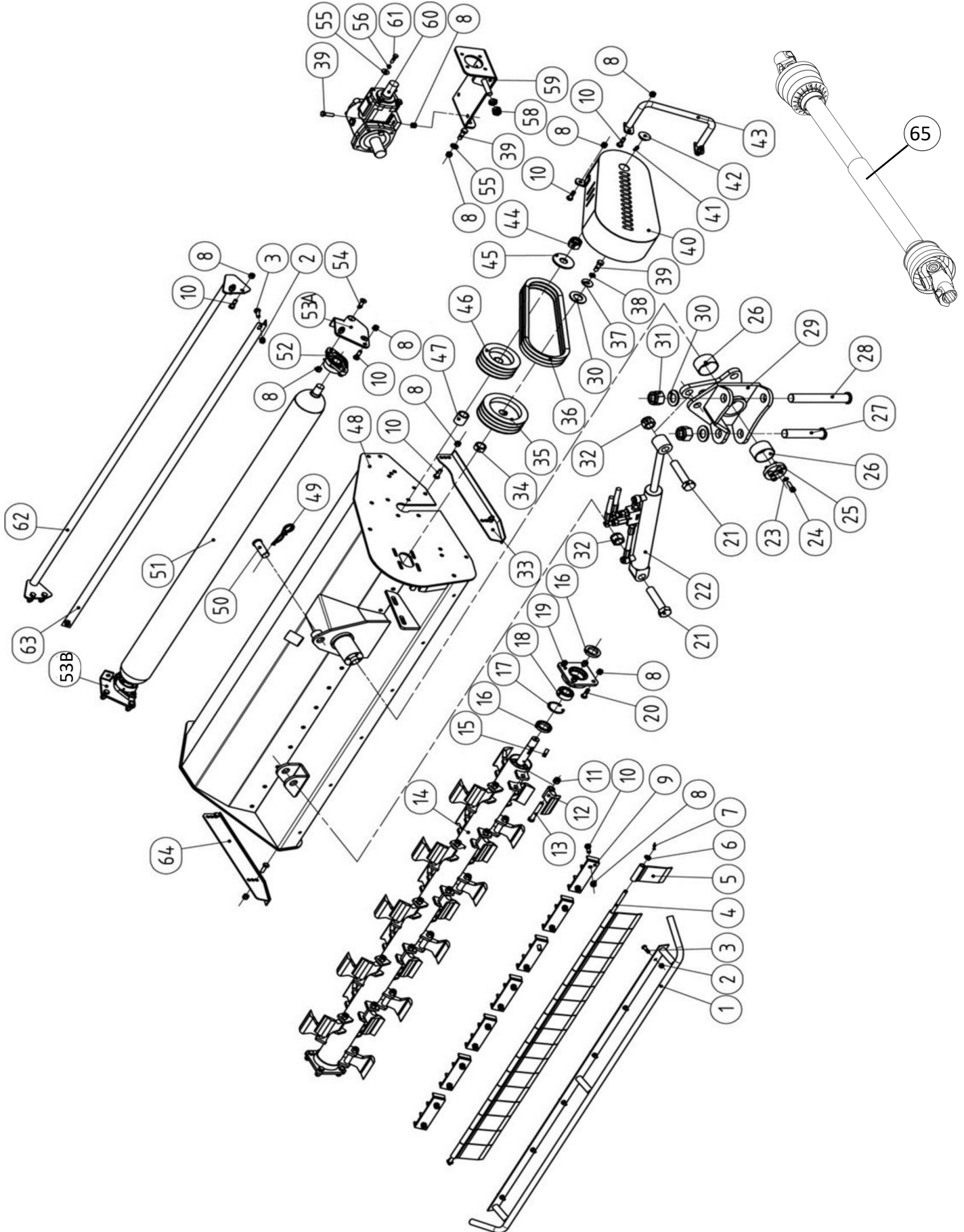

TRDB-053, TRDB-061 Assembly

Item	Part #	Description	Qty.
1	EM116-135	Safety Bar - front; TRDB-053	1
	EM116-155	Safety Bar - front; TRDB-061	1
2	LNМ08125	Self-locking nut M8-1.25	6
3	BM0812525	Bolt HH M8-1.25x25 (Full thread)	10
4	EM118-135	Protection plate shaft; TRDB-053	1
	EM118-155	Protection plate shaft; TRDB-061	1
5	BCM106A	Protection plate - M72 x 2	20
	BCM106B	Protection plate with gap- M72 x 2	20
	BCM106C	Protection plate - M51 x 2	20
	BCM106D	Protection plate - M43 x 2	20
6	FW10	Flat washer M10	2
7	CP4x25	Cotter pin M4 x 25	2
8	LNМ1015	Self-locking nut M10x1.5	41
9	BCL109	Counter knife	6
10	BM101530	Bolt HH M10-1.5x30 (Full thread)	28
11	LNМ12175	Self-locking nut M12-1.75	24
12	BCL112	400gr Forging hammer (Galv)	24
13	BM1217580	Bolt HH M12-1.75x80	24
14	BCL114-135	Rotor shaft; TRDB-053	1
	BCL114-155	Rotor shaft; TRDB-061	1
15	KW0828	Woodruff key- M8 x 28	1
16	OS355208	Oil seal- M35 x 52 x 8	3
17	SRI-52	Snap ring - Internal - M52	2
18	B2205	Bearing - 2205	2
19	BCL119	Rotor bearing seat	2
20	BM0812535	Bolt HH M8-1.25x35	8

NOTE: Optional "Y" Blade

00023013	"Y" blade	64
TFF10003	Spacer inner	64
LNМ12175	Self Locking Nut- M12 x 1.75	32
BM1217580	Bolt - M12 x 1.75 x 80	32

TRDB-053, TRDB-061 Assembly

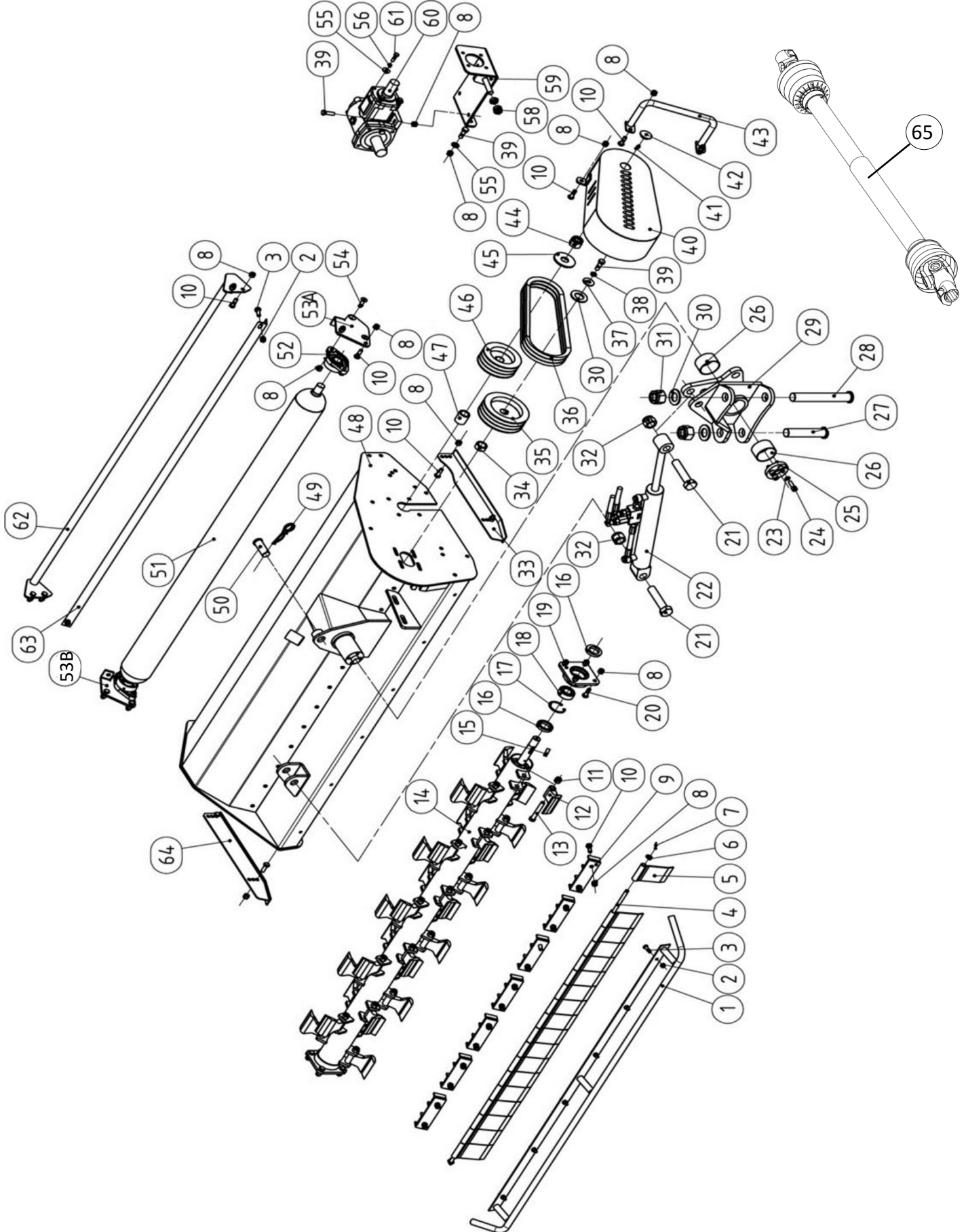

TRDB-053, TRDB-061 Assembly

Item	Part #	Description	Qty.
21	BM1620110	Bolt HH M16 x 2.0 x 110 (Full thread)	2
22	BCR301	Turning Cylinder	1
23	LW10	Washer lock M10	4
24	ABM101535	Allen Head Bolt M10-1.5 x 35	8
25	BCR125	Locking Board	1
26	B636840	Sleeve Bearing M63 x 68 x 40	2
27	BCM137	Pin	1
28	BCR128	Pin for the arm	1
29	BCR129	3-Point hitch	1
30	FW30	Flat washer M30	3
31	LNM3035	Nut self-locking M30-3.5	2
32	LNM1620	Nut self-locking M16-2.0	2
33	BCR133	Skid- left	1
34	BCR134	Bushing	1
35	BCR135-2G	Pulley- Upper (2 Groove) for TRDB-053	1
	BCR135-3G	Pulley- Upper (3 Groove) for TRDB-061	1
36	BCR136	Belt - BX 17x965	3
37	FW12	Washer flat M12	1
38	LW12	Washer lock M12	1
39	BM101535	Bolt M10-1.5x35 (Full thread)	4
40	BCR140	Belt cover	1
41	GN081S	Grease nipple M8-1.0 (Straight)	2
42	BCR142	Rubber cover M30	1
43	BCR143	Shield Protection Bar	1
44	LNM2430	Self-locking nut M24-3.0	1
45	FW24	Washer flat M24	1
46	BCR146-2G	Pulley- Lower (2 groove) for TRDB-053	1
	BCR146-3G	Pulley- Lower (3 groove) for TRDB-061	1
47	BCR147	Bushing	1
48	BCR148-135	Mower body TRDB-053	1
	BCR148-155	Mower body TRDB-061	1
49	HDPNRC4	Heavy Duty R-Clip- M4	1
50	SFTPN12	Safety pin- M12	1

TRDB-053, TRDB-061 Assembly

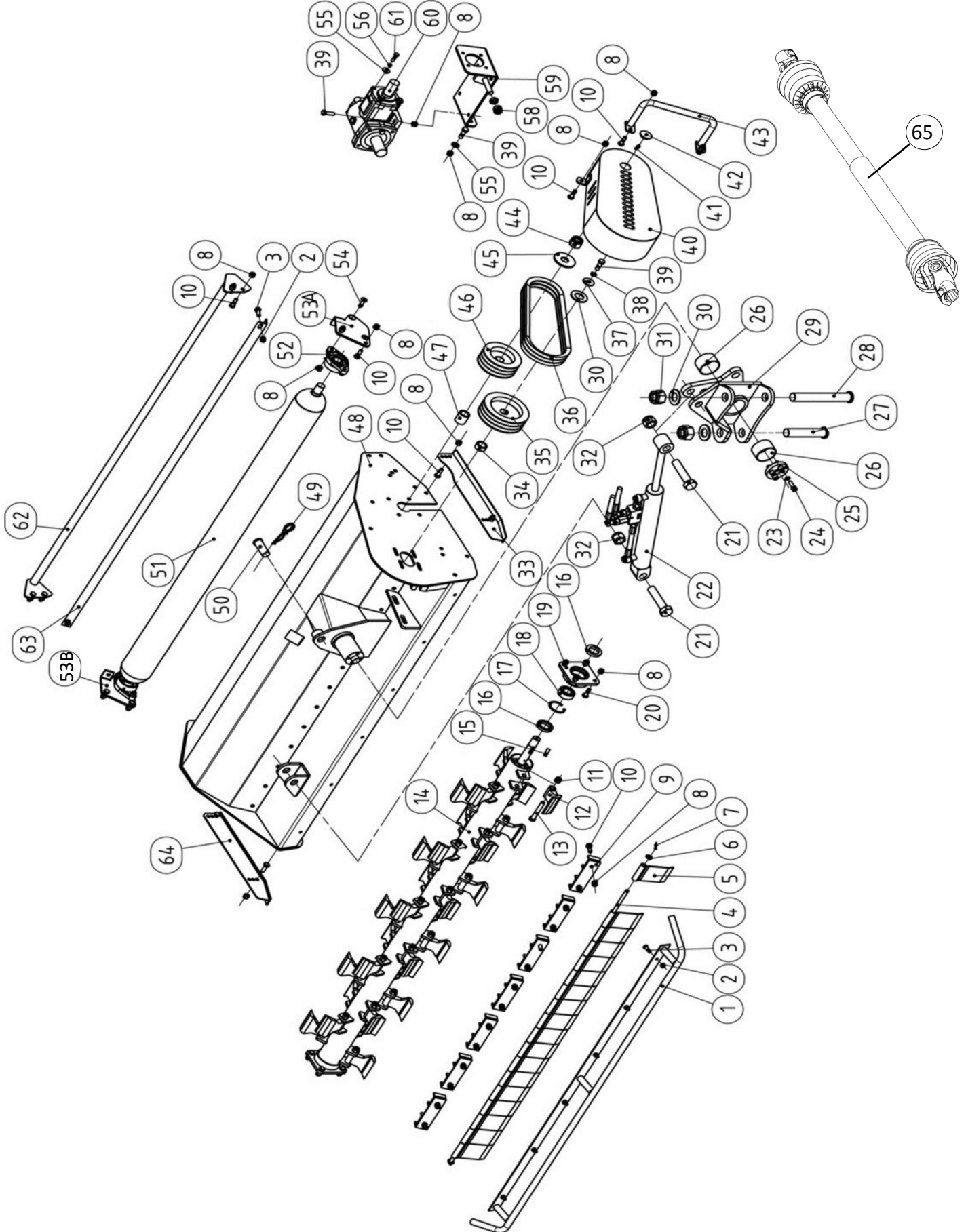

TRDB-053, TRDB-061 Assembly

Item	Part #	Description	Qty.
51	BCL151-135	Roller; TRDB-053	1
	BCL151-155	Roller; TRDB-061	1
52	UCFL205	UCFLU205 - Mounted bearing w/housing	2
53A	BCL153L	Left Bracket - For roller	1
53B	BCL153R	Right Bracket - For roller	1
54	SSM101535	Socket Screw - M10-1.5x35	4
55	FW08	Washer flat M8	8
56	LW08	Washer lock M8	6
57			
58	NM1620	Nut HH M16-2.0 (Thin)	3
59	BCL159	Gearbox Bracket	1
60	BCL160	Gearbox Complete - TRDB-053, TRDB-061	1
61	BM0812535	Bolt HH M8-1.25x35	4
62	BCL162-135	Rear safety bracket; TRDB-053	1
	BCL162-155	Rear safety bracket; TRDB-061	1
63	BCL163-135	Scraper; TRDB-053	1
	BCL163-155	Scraper; TRDB-061	1
64	BCL164	Skid - Right	1
65	BCMPTO	PTO complete	1

TRDB-053, TRDB-061 Hitch

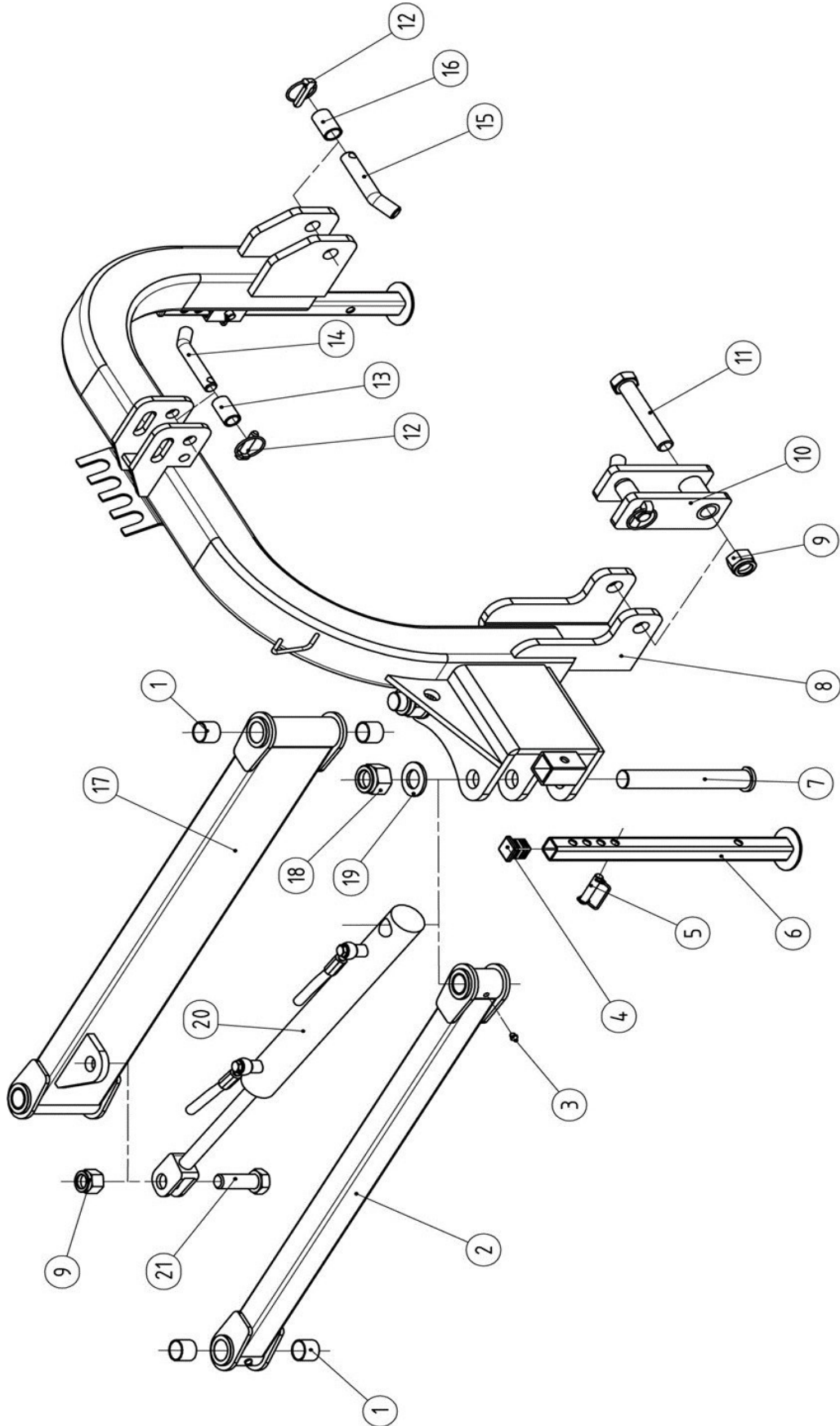

TRDB-053, TRDB-061 Hitch

Item	Part #	Description	Qty.
1	B343025	Sleeve Bearing - M34 x 30 x 25	8
2	BCL202	Swing Arm # 2	1
3	GN081S	Grease Nipple - M8-1.0 (Straight)	4
4	BCL204	Stand Plug	2
5	BCL205	Pin - M12	2
6	BCL206	Stand	2
7	BCL207	Pin for the arm	2
8	BCL208	BCRL Hitch	1
9	LNM243	Nut self-locking M24-3.0	2
10	BCL210	Extra Hitch Bracket	1
11	BM2430140	Bolt HH M24-3.0x140	1
12	LYNPN10	Lynch Pin - M10	3
13	BCL213	Bushing - (Cat 2) for Upper Hitch Connection	1
14	BCL214	Hitch Pin - Upper	1
15	BCL215	Hitch Pin - Lower	2
16	BCL216	Bushings (Cat 2) for Lower Hitch Connections	2
17	BCL217	Swing Arm # 1	1
18	LNM3035	Nut self-locking M30-3.5	2
19	FW30	Washer flat M30	2
20	BCR311	Swing Arm Cylinder	1
21	BM243065	Bolt HH M24-3.0x65 (Full thread)	1

TRDB-053, TRDB-061 Hydraulics Ver A

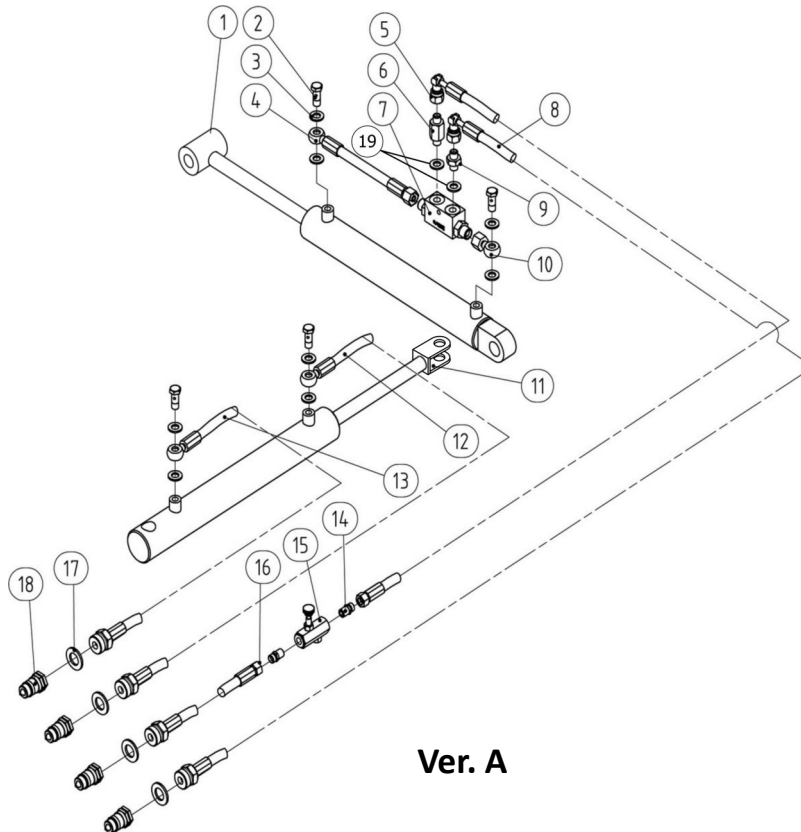

Item	Part #	Description	Qty.
1	BCR301	Turning cylinder	1
2	BANJOBM1212530	Bolt HH M12-1.25x30 (6mm orifice)	4
3	CW12	Compression washer – M12	8
4	BCR304	Short hydraulic hose on safety valve	1
5	BCR305	Hydraulic hose # 1 - Turning cylinder	1
6	BCR306	Connection adapter # 1 - Safety valve	1
7	BCR308	Safety valve	1
8	BCR307	Hydraulic hose # 2 on turning cylinder	1
9	BCR309	Connection adapter # 2 - Safety valve	1
10	BCM310	Connection adapter # 3 - Safety valve	1
11	BCR311	Swing Arm Cylinder	1
12	BCR312	Hydraulic hose # 1 for swing cylinder	1
13	BCR313	Hydraulic hose # 2 for swing cylinder	1
14	BCR314	Adapter on Flow Speed Valve	2
15	BCR315	Flow speed valve	1
16	BCR316	Hydraulic Hose # 3 on turning cylinder	1
17	CW1/2	Compression Washer M1/2	4
18	BCM318	Quick Release Coupling M1/2	4
19	CW13.5	Compression washer 13.5	2
-	BCM317	Hose extension 36" - TRDB (not shown)	2

TRDB-053, TRDB-061 Hydraulics Ver B

NOTE! Version B is for the following:

TRDB-053 Serial number 41100 & up

TRDB-061 Serial Number 42200 & up

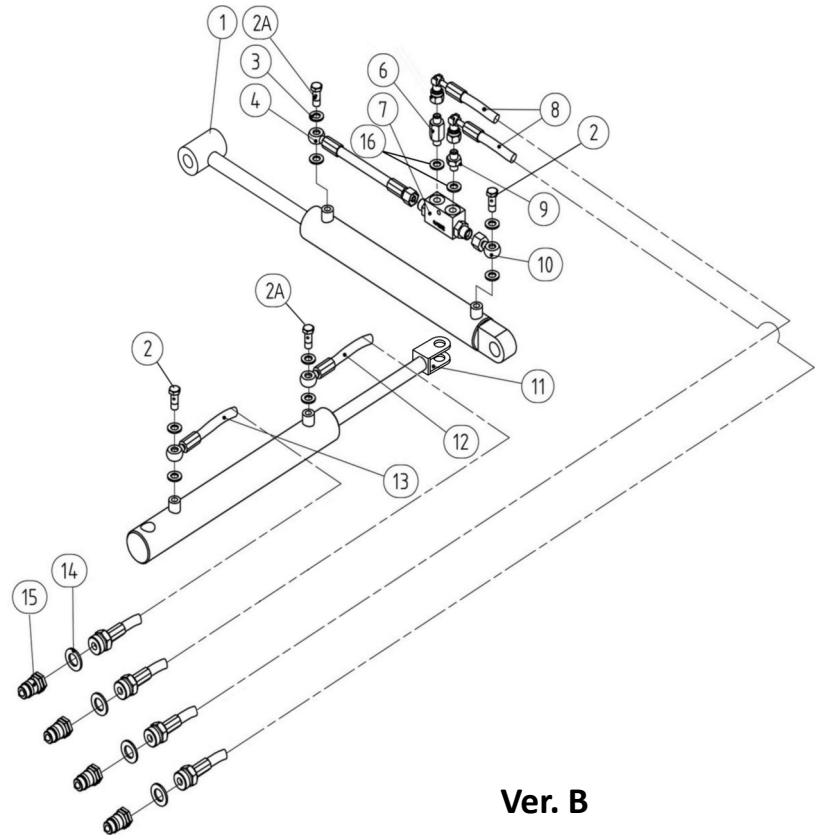

Item	Part #	Description	Qty.
1	BCR301	Turning cylinder	1
2	BANJOBM1212530	Bolt HH M12-1.25x30 (6mm orifice)	2
2A	BANJOBM1212525	Bolt HH M12-1.25x25 (1mm orifice)	2
3	CW12	Compression washer – M12	8
4	BCR304	Short hydraulic hose on safety valve	1
5			
6	BCR306	Connection adapter # 1 - Safety valve	1
7	BCR308	Safety valve	1
8	BCR307	Hydraulic hose # 2 on turning cylinder	2
9	BCR309	Connection adapter # 2 - Safety valve	1
10	BCM310	Connection adapter # 3 - Safety valve	1
11	BCR311	Swing Arm Cylinder	1
12	BCR312	Hydraulic hose # 1 for swing cylinder	1
13	BCR313	Hydraulic hose # 2 for swing cylinder	1
14	CW1/2	Compression Washer M1/2	4
15	BCM318	Quick Release Coupling M1/2	4
16	CW13.5	Compression washer 13.5	2
-	BCM317	Hose extension 36" - TRDB (not shown)	2

TRDB-069 Assembly

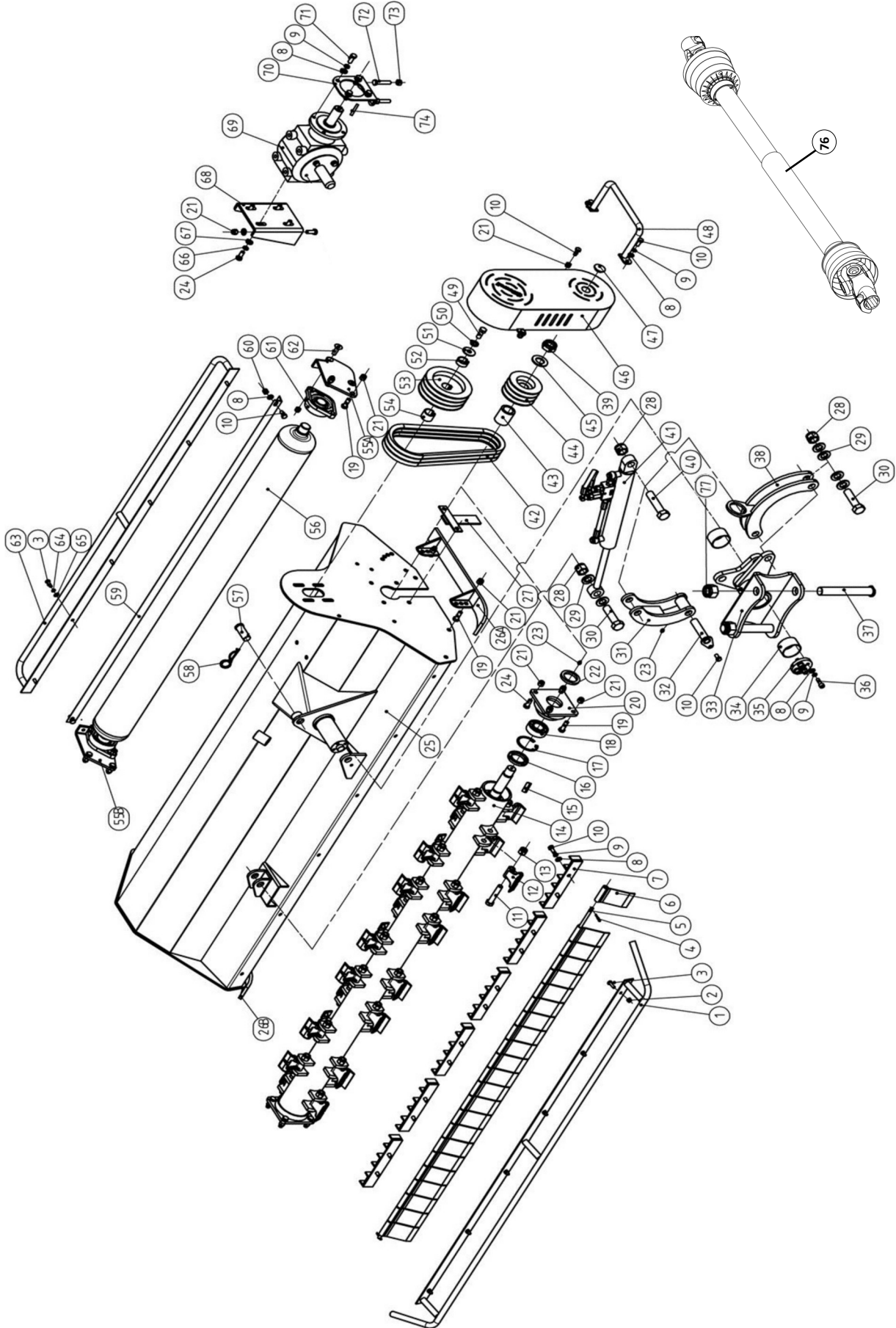

TRDB-069 Assembly

Item	Part #	Description	Qty.
1	EGC116-175	Front safety bar	1
2	LNLM08125	Nut self-locking M8-1.25	6
3	BM0812525	Bolt HH M8-1.25x25 (full thread)	6
4	CP4x25	Cotter pin - M4 x 25	2
5	EGC113-175	Protection Plate Shaft	1
6	BCM106A	Protection plate - M72 x 2	N
	BCM106B	Protection plate with gap - M72 x 2	N
	BCM106C	Protection plate - M51 X 2	N
	BCM106D	Protection plate - M43 X 2	N
7	BCM107	Counter knife	6
8	FW10	Washer flat M10	24
9	LW10	Washer lock M10	22
10	BM101525	Bolt HH M10-1.5x25	19
11	BM162085	Bolt HH M16-2.0x85	28
12	BCM112	800 gr. forging (Galv) hammer	28
13	LNLM1620	Nut self-locking M16-2.0	28
14	EGC126-175	Rotor shaft	1
15	KM100830	Key - M10 x 0.8 x 30	1
16	OS507208	Oil Seal- M50x72x 8	2
17	SRI-72	Snap Ring Internal - M72	2
18	B2207	Bearing - 2207	2
19	BM1217540	Bolt HH M12-1.75x40 (Full thread)	14
20	BCM120	Rotor Bearing Seat	2
21	SLNM12175	Nut self-locking M12-1.75	24
22	OS506808	Oil seal - M50 x 68 x 8	1
23	GN081S	Grease nipple - M8-1.0 Straight	4
24	BM1217530	Bolt HH M12-1.75x30 (Full thread)	8

TRDB-069 Assembly

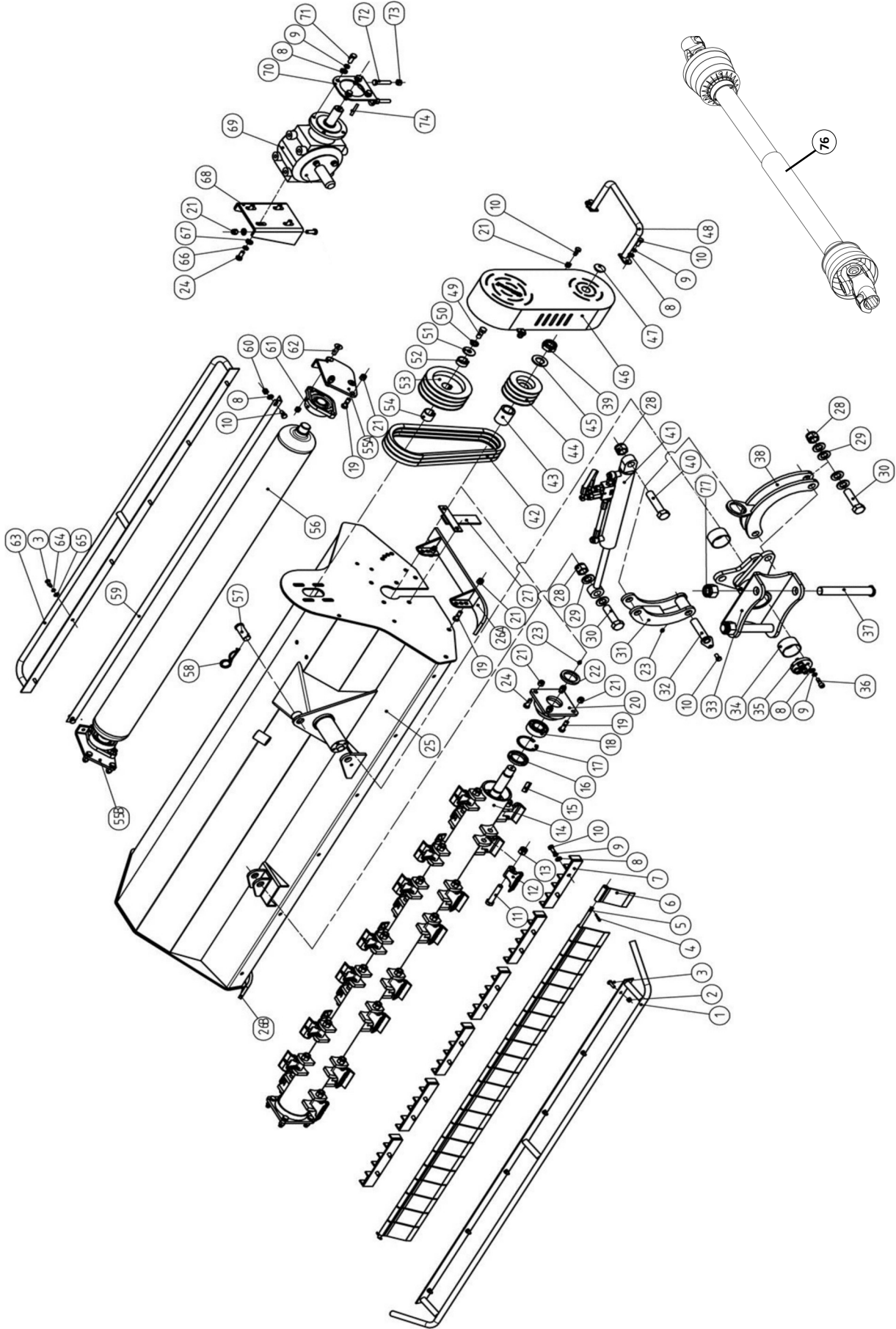

TRDB-069 Assembly

Item	Part #	Description	Qty.
25	BCM225-175	Mower body; TRDB-069	1
26	BCM126L	Skid- Left	1
	BCM126R	Skid- Right	1
27	BCM127	T plate	1
28	LNМ243	Self-locking nut- M24-3.0	3
29	FW24	Flat washer M24	6
30	BM243090	Bolt HH M24-3.0x90	2
31	BCM131	Rotating frame 2	1
32	BCM132	Rotating pivot pin	1
33	BCM133	Rotating frame 1	1
34	B636840	Sleeve bearing – M63 x 68 x 40	2
35	BCM135	Locking plate	1
36	ABM101525	Bolt allen socket head M10-1.5x25	4
37	BCM137	Pin for the arm	2
38	BCM138	Rotating frame 3	1
39	LNМ302	Nut self-locking M30-2.0	1
40	BM2430110	Bolt HH M24-3.0x110	1
41	BCM301	Turning Cylinder	1
42	BCM142	Belt - BX 17x1030	3
43	BCM143	Spacer	1
44	BCM144-4G	Lower pulley (4 groove)	1
	BCM144-3G	Lower pulley (3 groove)	1
45	FW30	Flat washer - M30	1
46	BCM146	Belt cover	1
47	BCM147-35	Rubber cover - M35	1
48	BCM148	Belt cover protection bar	1
49	BM142035	Bolt HH M14-2.0x35	1
50	LW14	Lock washer M14	1
51	LFW14	Large flat washer M14	1
52	BCM152	Bushing # 2	1
53	BCM153-3G	Upper pulley (3 groove)	1
	BCM153-4G	Upper pulley (4 groove)	1
54	BCM154	Bushing # 1	1
55A	BCM155L	Roller bearing bracket - LH	1
55B	BCM155R	Roller bearing bracket - RH	1
56	BCM156-175	Roller	1
57	SFTPN12	Safety pin- M12	1

TRDB-069 Assembly

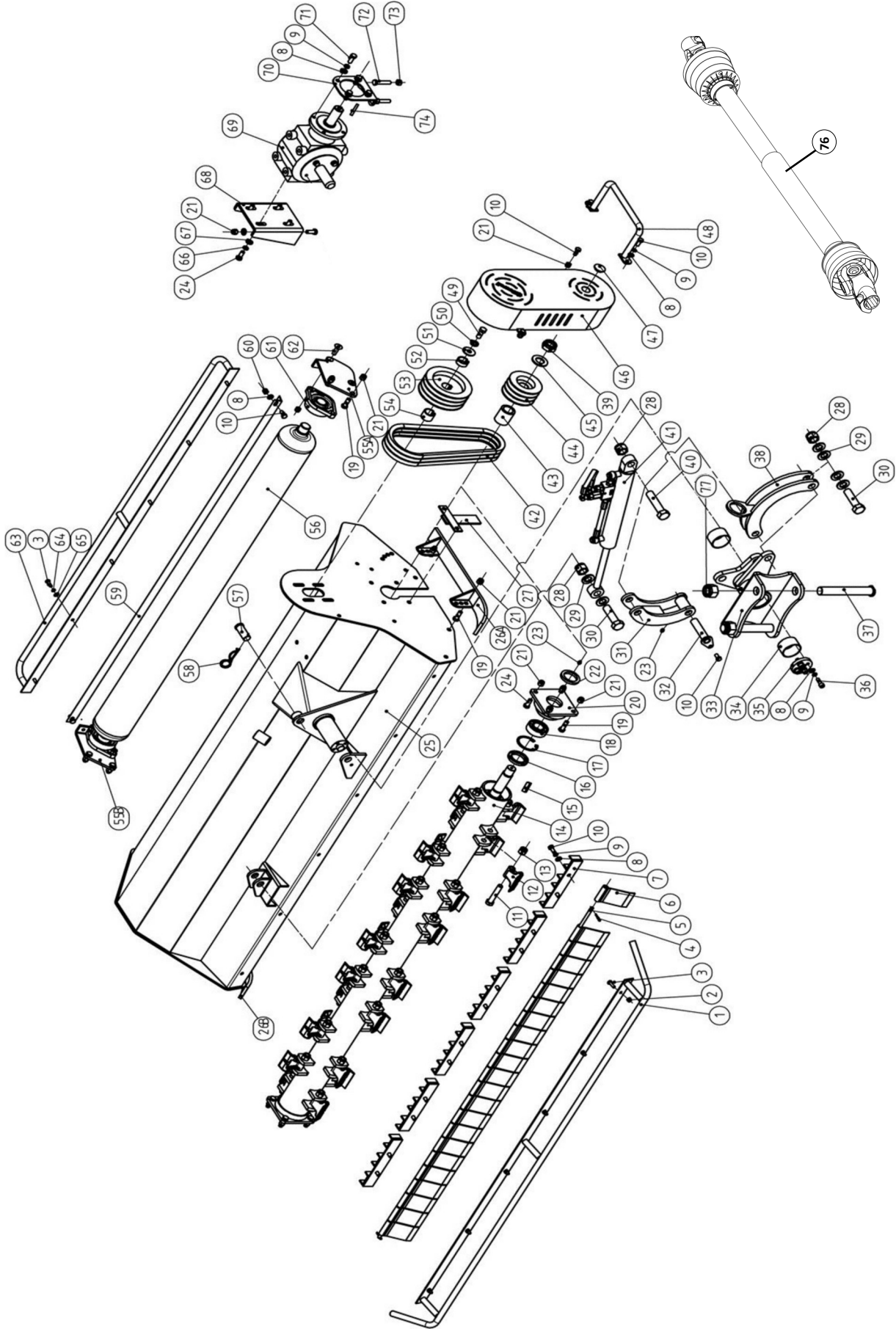

TRDB-069 Assembly

Item	Part #	Description	Qty.
58	HDPNRC4	R-Clip- M4	1
59	EGC163-175	Scraper	1
60	LNМ1015	Nut self-locking M10	2
61	UCFL207	Bearing with housing - UCFLU207	2
62	SSM1217540	Socket Screw - M12x40	4
63	EGC164-175	Safety bar - rear	1
64	LW08	Washer lock M8	10
65	FW08	Washer flat M8	10
66	LW12	Washer lock M12	6
67	FW12	Washer flat M12	6
68	BCM168	Gear box bracket	1
69	BCM169	Gear box	1
70	BCM170	Adjusting plate	1
71	BM121530	Bolt HH M10-1.5x30 (Full thread)	4
72	BM1212550	Bolt HH M12-1.25x50 (Full thread)	2
73	NM12125	Nut HH M12-1.25	2
74	KM100865	Key - M10 x 8 x 65 for gear box	1
75			
76	BCMPTO	PTO complete	1
77	LNМ3035	Nut self-locking M30-3.5	2

TRDB-069 Hitch

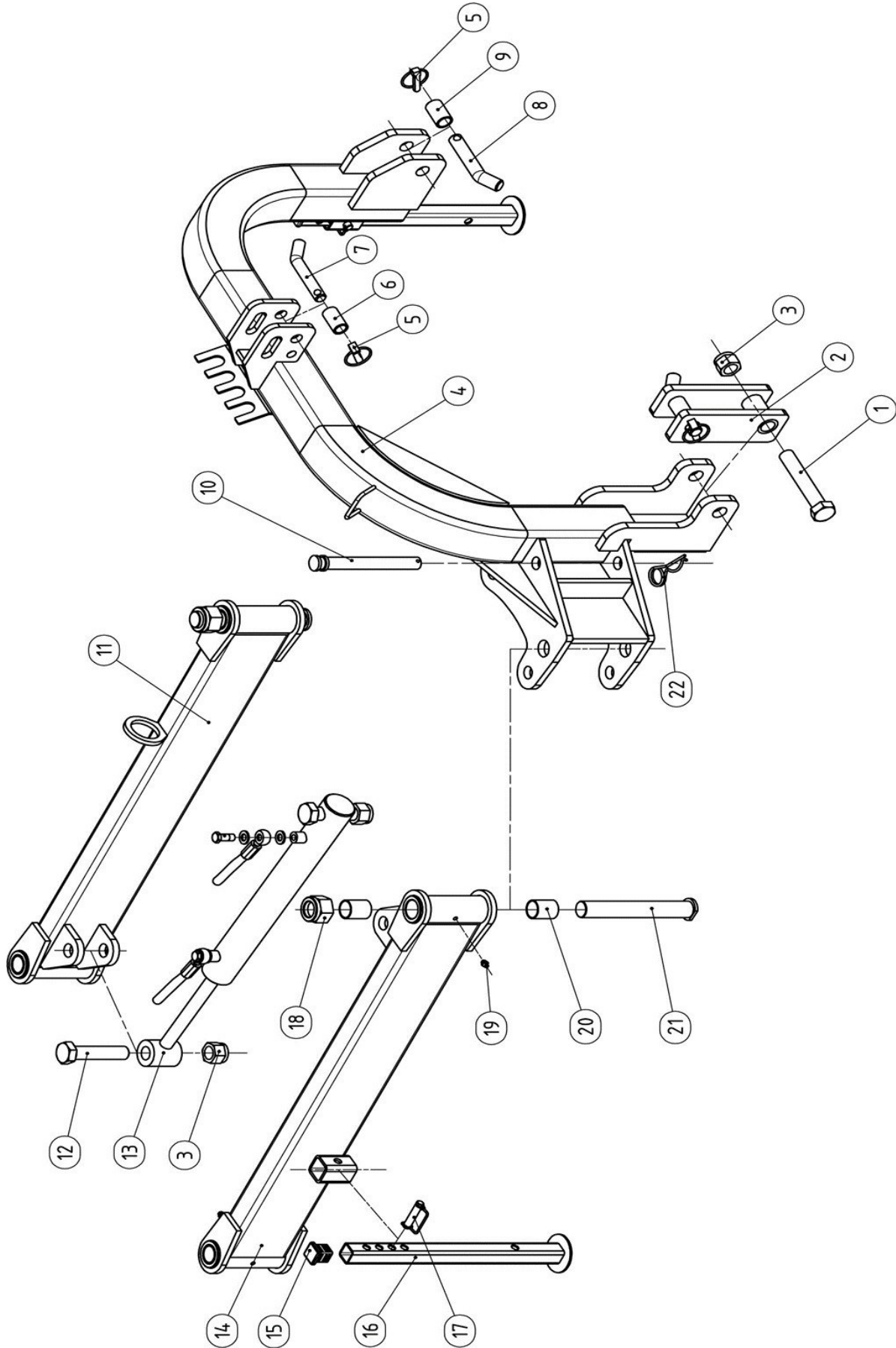

TRDB-069 Hitch

Item	Part #	Description	Qty.
1	BM2430140	Bolt HH M24-3.0x140	1
2	BCM202	Small extra hitch	1
3	LNM243	Nut self-locking M24	3
4	BCM204	3-point hitch	1
5	LYNPN10	Lynch pin - M10	3
6	BCM206	Bushing for upper hitch- (Cat 2)	1
7	BCM207	Upper hitch pin	1
8	BCM208	Lower hitch pin	2
9	BCM209	Cat 2 Bushing for lower hitch	2
10	BCM210	Pin for Swing Arm	1
11	BCM211	Arm # 1	1
12	BM2430110	Bolt HH M24-3.0x110	2
13	BCM311	Swing Arm Cylinder	1
14	BCM214	Arm # 2	1
15	BCM215	Square plug	2
16	BCM216	Stand	2
17	SFTPN12	Safety Pin - M12	2
18	LNM3035	Nut self-locking M30-3.5	4
19	GN081S	Grease Nipple M8x1	4
20	B343040	Sleeve bearing M34 x 30 x 40	8
21	BCM137	Pin	2
22	HDPNRC4	Heavy Duty R-Clip- M4	1

TRDB-069 Hydraulics Ver A

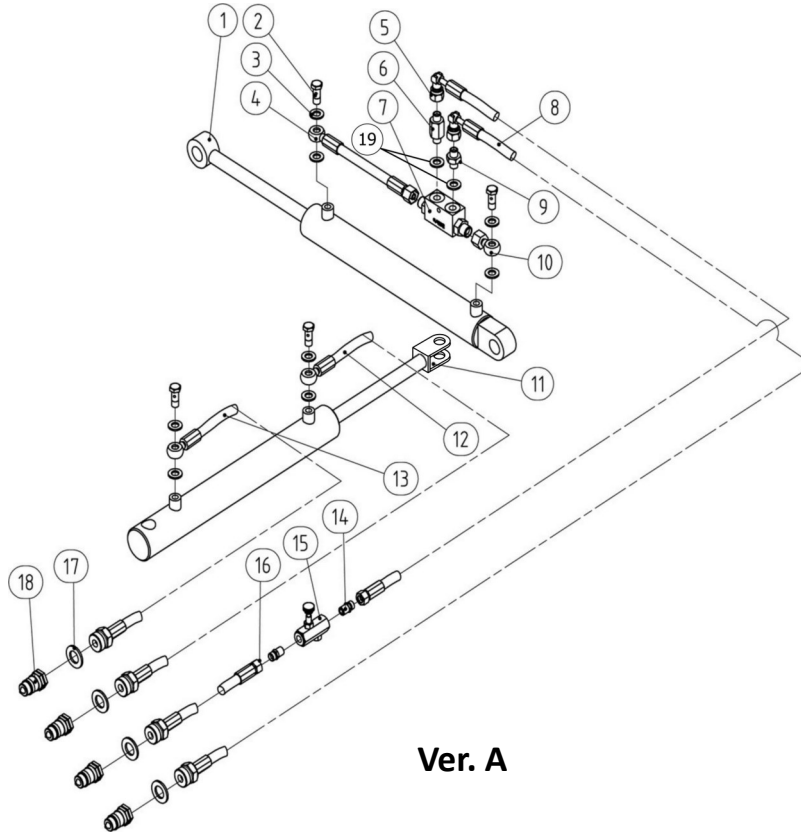

Ver. A

Item	Part #	Description	Qty.
1	BCM301	Turning cylinder	1
2	BANJOBM1212530	Bolt HH M12-1.25x30	4
3	CW12	Compression washer – M12	8
4	BCR304	Short hydraulic hose on safety valve	1
5	BCR305	Hydraulic hose # 1 - Turning cylinder	1
6	BCR306	Connection adapter # 1 - Safety valve	1
7	BCR308	Safety valve	1
8	BCR307	Hydraulic hose # 2 on turning cylinder	1
9	BCR309	Connection adapter # 2 - Safety valve	1
10	BCM310	Connection adapter # 3 - Safety valve	1
11	BCM311	Swing Arm Cylinder	1
12	BCR312	Hydraulic hose # 1 for swing cylinder	1
13	BCR313	Hydraulic hose # 2 for swing cylinder	1
14	BCR314	Adapter on Flow Speed Valve	2
15	BCR315	Flow speed valve	1
16	BCR316	Hydraulic Hose # 3 on turning cylinder	1
17	CW1/2	Compression Washer M1/2	4
18	BCM318	Quick Release Coupling M1/2	4
19	CW13.5	Compression washer 13.5	2
-	BCM317	Hose extension 36" - TRDB (not shown)	2

TRDB-069 Hydraulics Ver B

NOTE! Version B is for the following:

TRDB-069 Serial number 51200 & up

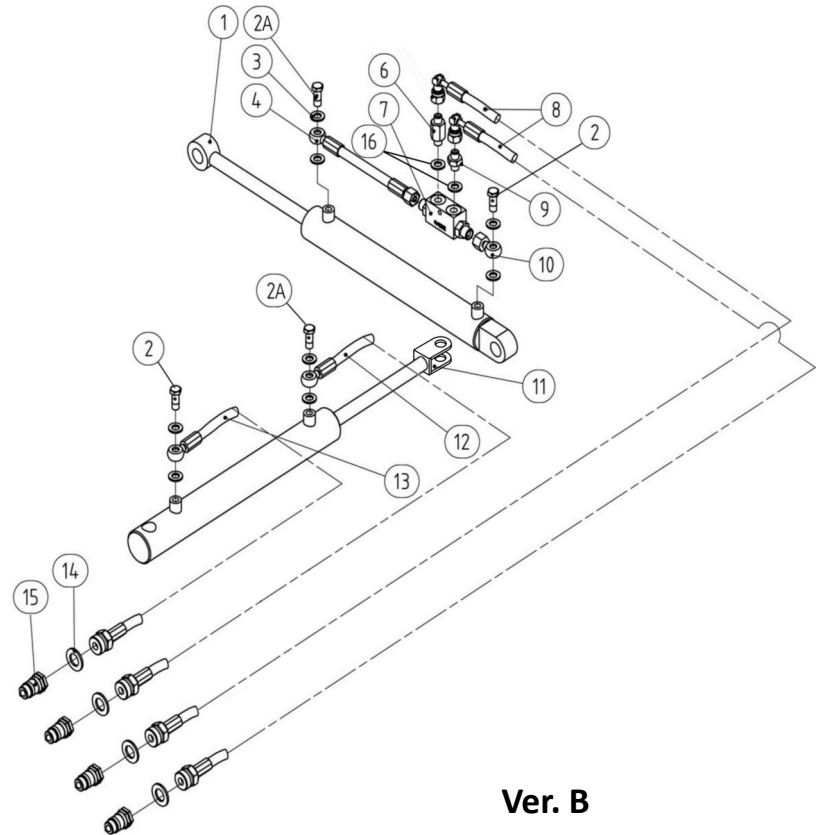

Ver. B

Item	Part #	Description	Qty.
1	BCM301	Turning cylinder TRDB-069	1
2	BANJOBM1212530	Bolt HH M12-1.25x30 (6mm orifice)	2
2A	BANJOBM1212525	Bolt HH M12-1.25x25 (1mm orifice)	2
3	CW12	Compression washer – M12	8
4	BCR304	Short hydraulic hose on safety valve	1
5			
6	BCR306	Connection adapter # 1 - Safety valve	1
7	BCR308	Safety valve	1
8	BCR307	Hydraulic hose # 2 on turning cylinder	2
9	BCR309	Connection adapter # 2 - Safety valve	1
10	BCM310	Connection adapter # 3 - Safety valve	1
11	BCM311	Swing Arm Cylinder TRDB-069	1
12	BCR312	Hydraulic hose # 1 for swing cylinder	1
13	BCR313	Hydraulic hose # 2 for swing cylinder	1
14	CW1/2	Compression Washer M1/2	4
15	BCM318	Quick Release Coupling M1/2	4
16	CW13.5	Compression washer 13.5	2
-	BCM317	Hose extension 36" - TRDB (not shown)	2

TRDB-069 Gearbox

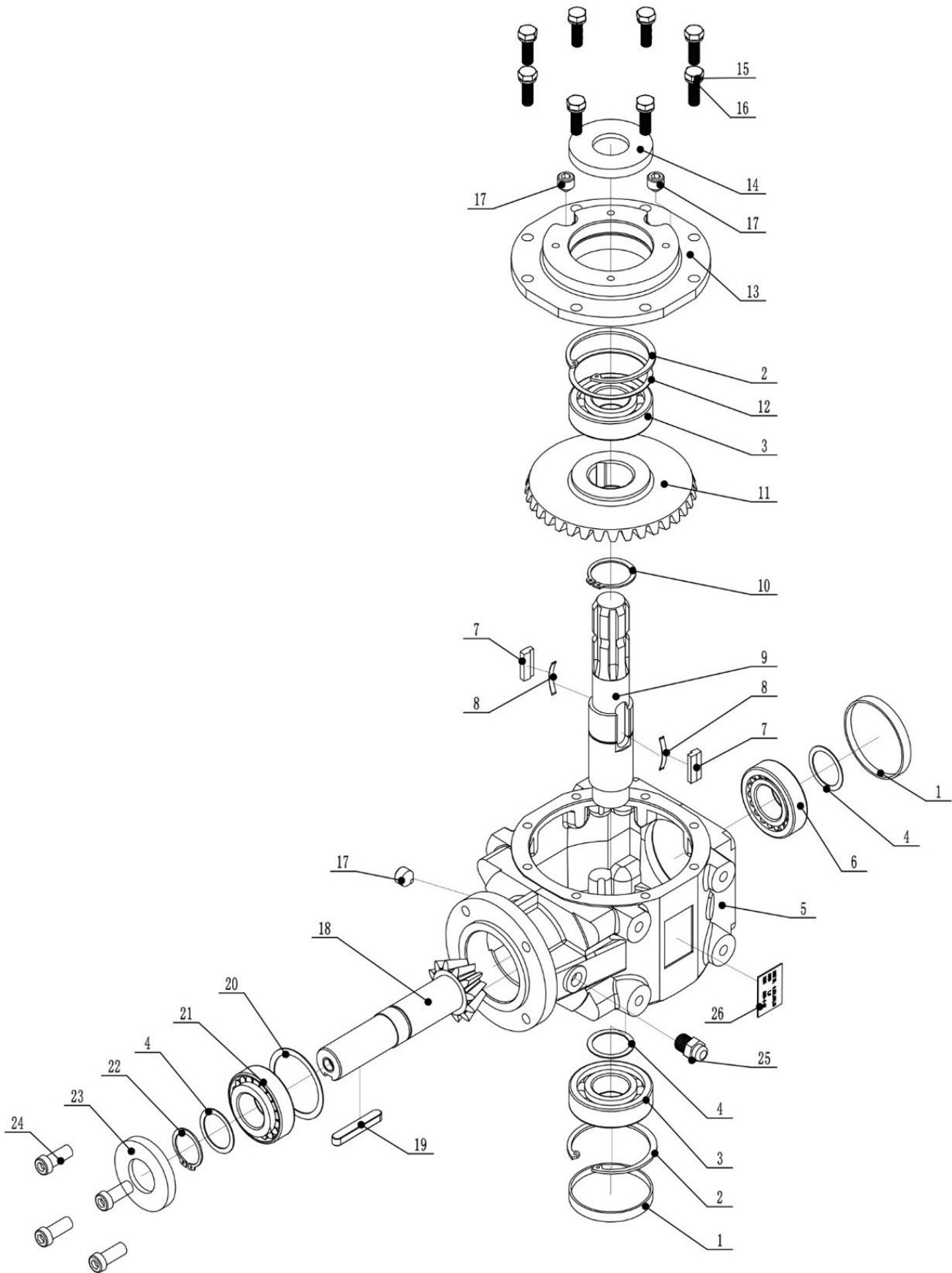

TRDB-069 Gearbox

Item	Part #	Description	Qty.
1	BCRM-001	End cap 80x10	2
2	SRI-80	Snap Ring - Internal - M80x2.5	2
3	B6307	Bearing 6307 (35x80x21)	2
4	BCRM-004	Shim 35.5x72x24.25	-
5	BCRM-005	Housing	1
6	B32207	Roller Bearing 32207 (35x72x24.25)	1
7	BCRM-007	Key	2
8	BCRM-008	Spring plate	2
9	BCRM-009	Input shaft	1
10	SRE-42	Snap ring 42x1.5	1
11	BCRM-011	Bevel gear	1
12	BCRM-012	Shim 70x79.8x0.3-1.0	-
13	BCRM-013	Input cap	1
14	OS358010	Oil seal 35x80x10	8
15	BM101530	Bolt HH M10-1.5x30	8
16	LW10	Washer flat M10	8
17	BCRM-017	Nut HH 3/8-18 NPT	3
18	BCRM-018	Output pinion gear	1
19	KM100865B	Key 10x8x65	1
20	BCRM-020	Shim 62x71.9x0.3-1.0	-
21	B30207	Bearing 30207 35x72x18.25	1
22	SRE-35	Snap ring 35x2.5	1
23	OS357210	Oil seal 35x72x10	1
24	BM1217530	Bolt HH M12-1.75x30 (Full thread)	4
25	OP3/8-18B	Breather plug 3/8-18 NPT	1
-	BCM169	Gearbox complete TRDB-069	1

PTO

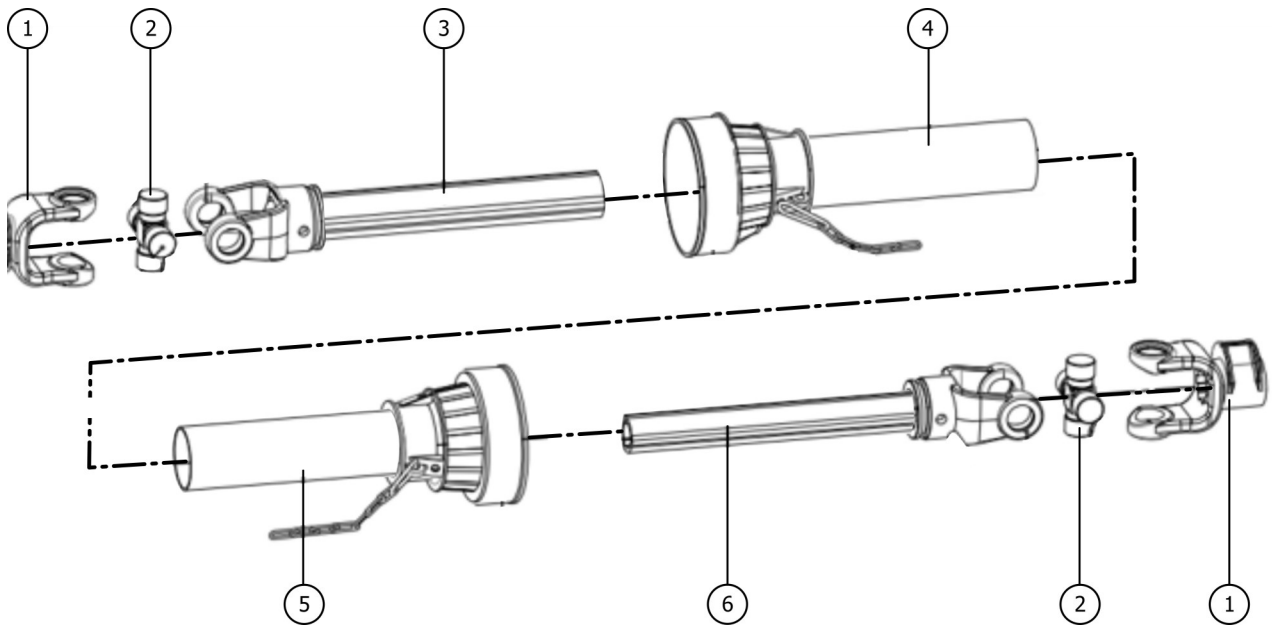

PTO

Item	Part #	Description	Qty.
1	DP1075-40	PTO Yoke - Series 40	1
2	DP1076-40	Cross and Bearings - Series 40	2
3	DP1079-40	Female Yoke and Tube (tractor end) - Series 40	1
4	DP1074F-40	Complete Female End PTO Shielding (tractor end)	1
5	DP1074M-40	Complete Male End PTO Shielding (implement end)	1
6	DP1078-40	Male Yoke & Tube (IE) - Series 40	1

TRDB Decals

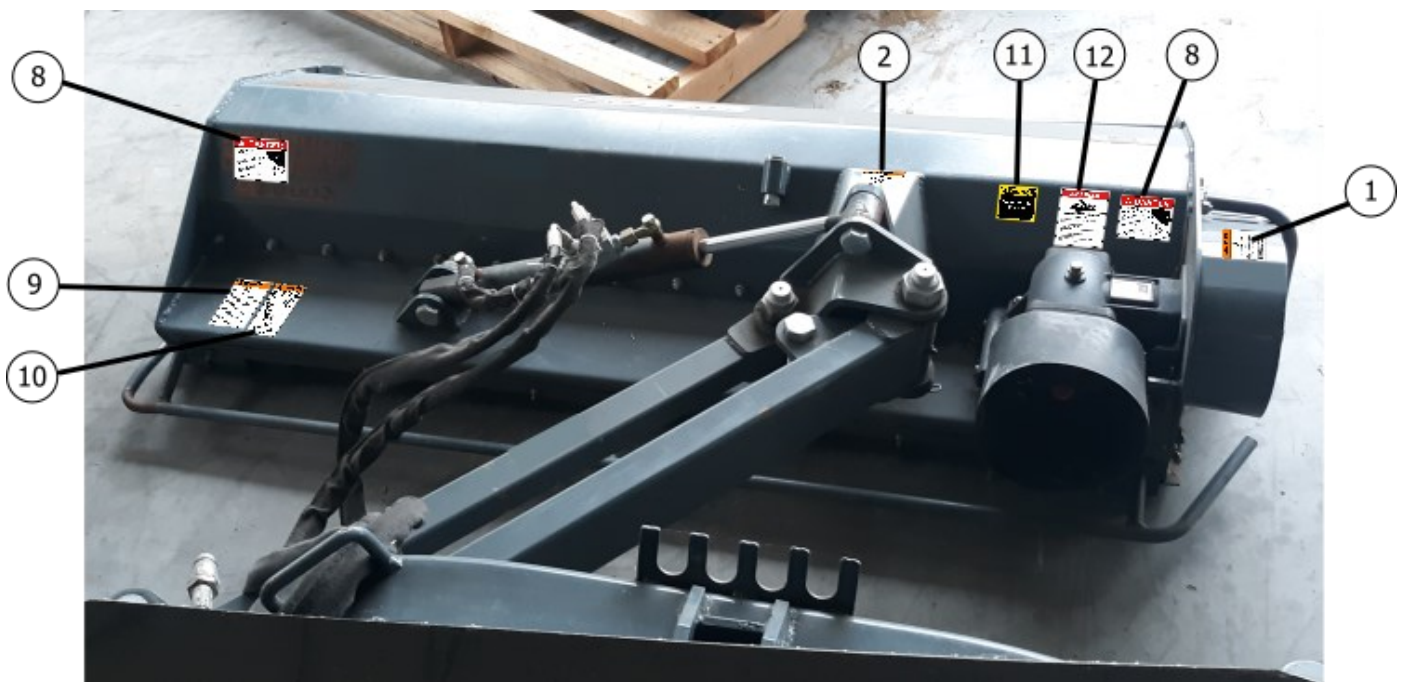

TRDB Decals



1



2



3



5



7

TRDB-053
TRDB-061
TRDB-069

4



6



8



9

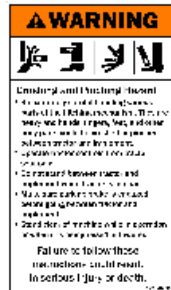

10



11



12

Item	Part #	Description	Qty.
1	RT1004E	Decal Warning Moving Part Hazard	1
2	RT1005	Decal Warning To Prevent Serious Injury or Death	1
3	Z94008	Decal Warning Thrown Objects	1
4	-	Decal Model # TRDB-053	-
	-	Decal Model # TRDB-061	-
	-	Decal Model # TRDB-069	-
5	D960	Decal Warning Cancer and Reproductive Harm	1
6	D1016	Decal Logo Tar River Implements	1
7	-	Serial Tag Tar River Implements, Made in China	1
8	Z94007	Decal Danger Rotating Cutting Blades	2
9	RT1004D	Decal Warning To Prevent Serious Injury or Death	1
10	950407B	Decal Warning Crushing and Pinching Hazard	1
11	D1000	Decal Caution Operate only with 540 rpm PTO	1
12	RT1007	Decal Danger Rotating Driveline Hazard	1

Warranty

LIMITED WARRANTY

Belco Resources Equipment warrants to the original purchaser of any new piece of machinery from Belco Resources Equipment, purchased from an authorized Belco Resources Equipment dealer, that the equipment be free from defects in material and workmanship for a period of one (1) year for non-commercial, state, and municipalities' use, ninety (90) days for commercial use from date of retail sale. Warranty for rental purposes is thirty (30) days. The obligation of Belco Resources Equipment to the purchaser under this warranty is limited to the repair or replacement of defective parts.

Replacement or repair parts installed in the equipment covered by this limited warranty are warranted for ninety (90) days from the date of purchase of such part or to the expiration of the applicable new equipment warranty period, whichever occurs later. Warranted parts shall be provided at no cost to the user at an authorized Belco Resources Equipment dealer during regular working hours. Belco Resources Equipment reserves the right to inspect any equipment or parts, which are claimed to have been defective in material or workmanship.

This limited warranty does not apply to and excludes wear items such as shear pins, tires, tubes knives, blades or other wear items. Oil or grease is not covered by this warranty.

All obligations of Belco Resources Equipment under this limited warranty shall be terminated if:

- Proper service is not performed on the machine.

- The machine is modified or altered in any way.

- The machine is being used or has been used for purposes other than those for which the machine was intended.

DISCLAIMER OF IMPLIED WARRANTIES & CONSEQUENTIAL DAMAGES

Belco Resources Equipment obligation under this limited warranty, to the extent allowed by law, is in lieu of all warranties, implied or expressed, including implied warranties of merchantability and fitness for a particular purpose and any liability for incidental and consequential damages with respect to the sale or use of the items warranted. Such incidental and consequential damages shall include but not be limited to: transportation charges other than normal freight charges; cost of installation other than cost approved by Belco Resources Equipment; duty; taxes; charges for normal service or adjustment; loss of crops or any other loss of income; rental of substitute equipment, expenses due to loss, damage, detention or delay in the delivery.

REGISTRATION

The online Warranty Registration must be completed in order to qualify for coverage on this Limited Warranty. Visit br-equipment.com, click on "Warranty Registration" and completely fill out the form to register the new piece of equipment.

Page left blank intentionally



401 Jeffreys Road
Rocky Mount, NC 27804
www.tarrivermfg.com

Tel: 252-822-7140
Fax: 252-787-5855
Sales@tarrivermfg.com