



# Mini Round Baler

## SRB-870 Twine Wrap



### Owner's Manual

**Page left blank intentionally**

**TO THE DEALER:**

Assembly and proper installation of this product is the responsibility of the Tar River dealer. Read manual instructions and safety rules. Make sure all items on the Dealer's Pre-Delivery and Delivery Check Lists in the Owner's/Operator's Manual are completed before releasing equipment to the owner.

**TO THE OWNER:**

Read this manual before operating your Tar River equipment. The information presented will prepare you to do a better and safer job. Keep this manual handy for ready reference. Require all operators to read this manual carefully and become acquainted with all the adjustment and operating procedures before attempting to operate. Replacement manuals can be obtained from your selling dealer. The equipment you have purchased has been carefully engineered and manufactured to provide dependable and satisfactory use. Like all mechanical products, it will require cleaning and upkeep. Lubricate the unit as specified. Observe all safety information in this manual and safety decals on the equipment. For service, your authorized Tar River dealer has trained mechanics, genuine Tar River service parts, and the necessary tools and equipment to handle all your needs. Use only genuine Tar River service parts. Substitute parts will void the warranty and may not meet standards required for safe and satisfactory operation.

Record your implement model and serial number in the space provide below. Your dealer will need this information to give you prompt, efficient service.

**Model Number:** \_\_\_\_\_

**Serial Number:** \_\_\_\_\_

**Date Purchased:** \_\_\_\_\_

## TO THE DEALER: Part 1 of 2

Assembly and proper installation of this product is the responsibility of the Belco Resources Dealer. Read manual instructions and safety rules. Make sure all items on the Dealer’s Pre-Delivery List and Owners Check List in the Owner’s/Operator’s Manual are completed before releasing equipment to the owner.



**NOTE: The machine must be inspected thoroughly by the dealer prior to delivery of machine to owner. Place a check mark in the box beside each item checked. Contact Belco Recourses Equipment of any damages, issues or shortages to the machine.**

### Pre-Delivery Checklist - Dealer

- Gearbox oil level
- Check all fluids, hydraulic, gear oil, etc.
- Grease fittings properly lubricated
- Guards, shields, attachments securely fastened
- All hardware tightened
- Condition and tension of V-belts (if applicable)
- Blades properly installed, blade hardware tightened to proper torque specifications
- PTO attached to the machine (if applicable)
- All decals are clean, legible and in proper location
- Operator’s Manual on machine

Model #: \_\_\_\_\_ Serial #: \_\_\_\_\_

Inspected by (Initials): \_\_\_\_\_ Date: \_\_\_\_\_

## TO THE DEALER: Part 2 of 2

Dealer is to review the following items to the owner. Place a check mark in the box beside each item reviewed.

### Checklist - Owner

- Correct attachment of machine to tractor
- Safe operation of the machine
- Importance of regular lubrication, maintenance and inspection
- Troubleshooting
- Replacing broken or worn parts (importance of using only OEM parts)
- Servicing the machine
- Storage
- Warranty
- Encourage owner to read and understand the Operator’s Manual before operating the machine
- Encourage owner to fill out the “Warranty Registration”, online [warranty@br-equipment.com](mailto:warranty@br-equipment.com)

<b>Purchase Date:</b> _____	<b>Delivery Date:</b> _____
<b>Model #:</b> _____	<b>Serial #:</b> _____
<b>Dealer Signature</b> _____	<b>Date:</b> _____
<b>Customer Signature</b> _____	<b>Date:</b> _____

### TO THE OWNER:

Read this manual before operating your Belco Resources equipment. The information presented will prepare you to do a better and safer job. Keep this manual handy for ready reference. Require all operators to read this manual carefully and become acquainted with all the adjustment and operating procedures before attempting to operate. Replacement manuals can be obtained from your selling dealer. The equipment you have purchased has been carefully engineered and manufactured to provide dependable and satisfactory use. Like all mechanical products, it will require cleaning and upkeep. Lubricate the machine as specified. Observe all safety information in this manual and safety decals on the equipment. For service, your authorized Belco Resources dealer has trained mechanics, genuine Belco Resources service parts, and the necessary tools and equipment to handle all your needs. Use only genuine Belco Resources service parts. Substitute parts will void the warranty and may not meet standards required for safe and satisfactory operation.

# Table of Contents

Introduction .....	7
Technical Specifications .....	7
Safety .....	8
Safety Signal Words .....	8
General Safety Guidelines .....	9
Safety Decal Care .....	9
Before Operation .....	10
During Operation .....	11
Highway And Transport Operations .....	12-13
PTO Driveline Instructions.....	14-17
Assembly.....	18-22
Operating Instructions .....	23-24
Adjustments .....	25-32
Maintenance .....	33-35
Torque Specifications .....	36
Parts Breakdown .....	37-71
Warranty .....	72

## Technical Specifications

Thank you for purchasing your Tar River SRB-870 Mini Round Baler. The Tar River SRB-870NW Mini Round Baler is perfect for the small farmer who wants to produce their own hay. The SRB-870 secures the bale with twine wrapping system. The SBR-870 comes with a self-contained hydraulic pump. The baler is operated by remote control from the tractor seat.

### Technical Specifications

Model	SRB-870
Size (L x W x H)	44" x 51" x 51"
Weight	1,150 lbs.
Hitch	Cat. 1
Tractor PTO HP	18-30 HP
Bale Size	23" x 28"
Tire Size	16 x 6.50 x 8"
Pickup Width	20" or 30"
Bale Wrapping	Twine
Working Capacity	80-100 bales/hr
Hydraulics	Self-contained Tailgate Opener

## Important Safety Information

### Safety

It is important that you read the entire manual and to become familiar with this product before you begin using it. This product is designed for certain applications only. The manufacturer cannot be responsible for issues arising from modification. We strongly recommend this product not be modified and /or used for any application other than that for which it is designed. If you have any questions relative to a particular application, DO NOT use the product until you have first contacted us to determine if it can or should be performed on the product.

Read and understand this manual and all safety signs before operating and maintaining . Review the safety instructions and precautions annually.

### Safety Signal Words

**TAKE NOTE! This safety alert symbol found throughout this manual is used to call you attention to instructions involving you personal safety and the safety of others. Failure to follow these instructions can result in injury or death.**



**This symbol means:  
Attention!  
Become alert!  
Your safety is involved!**

Note the use of the signal words, **DANGER, WARNING and CAUTION** with the safety messages. The appropriate signal word for each has been selected using the following guidelines:



**DANGER:** Indicates an imminently hazardous situation that, if not avoided, will result in death or serious injury. This signal word is to be limited to the most extreme situations typically for machine components which, for functional purposes, cannot be guarded.

**WARNING:** Indicates a potentially hazardous situation that, if not avoided, could result in death or serious injury, and includes hazards that are exposed when guards are removed. It may also be used to alert against unsafe practices.



**CAUTION:** Indicates a potentially hazardous situation that, if not avoided, may result in minor or moderate injury. It may also be used to alert against unsafe practices.

## Important Safety Information

### General Safety Guidelines

Safety of the operator is one of the main concerns in designing and developing a new piece of equipment. Designers and manufacturers build in as many safety features as possible. However, every year many accidents occur which could have been avoided by a few seconds of thought and a more careful approach to handling equipment. You, the operator, can avoid many accidents by observing the following precautions in this section. To avoid personal injury, study the following precautions and insist those working with you, or for you, follow them.

Replace any **DANGER, WARNING, CAUTION** or instruction safety decal that is not readable or is missing. Location of such decals are indicated in this manual. Do not attempt to operate this equipment under the influence of drugs or alcohol.

Review the safety instructions with all users annually.

This equipment is dangerous to children and persons unfamiliar with its operation. The operator should be a responsible adult familiar with farm machinery and trained in this equipment's operations. **Do not allow persons to operate or assemble this unit until they have read this manual and have developed a thorough understanding of the safety precautions and of how it works.**

To prevent injury of death, use a tractor equipped with a Roll Over Protection System (ROPS). Do not paint over, remove or deface any signs or warning decals on your equipment. Observe all safety signs and practice the instructions on them.

Never exceed the limits of a piece of machinery. If its ability to do a job, or to do so safely, is in question - **Don't try it!**



### Safety Decal Care

- Keep safety signs clean and legible at all times.
- Replace safety signs that are missing or have become illegible.
- Replaced parts that displayed a safety sign should also display the current safety sign
- Safety signs are available from your Distributor or Dealer Parts Department or the factory.

## Important Safety Information

### How to install Safety Signs:

- Be sure that the installation area is clean and dry.
- Decide on the exact position before you remove the backing paper.
- Remove the smallest portion of the split backing paper.
- Align the decal over the specified area and carefully press the small portion with the exposed sticky backing in place.
- Slowly peel back the remaining paper and carefully smooth the remaining portion of the decal in place.
- Small air pockets can be pierced with a pin and smoothed out using the piece of decal backing paper.



### Before Operation

- Carefully study and understand this manual.
- Do not wear loose-fitting clothing, which may catch in moving parts.
- Always wear protective clothing and substantial shoes.
- Assure that all tires are inflated evenly.
- Give the unit a visual inspection for any loose bolts, worn parts or cracked welds, and make necessary repairs. Follow the maintenance safety instructions included with this manual.
- Be sure that there are no tools lying on or in the equipment.
- Do not use the unit until you are sure that the area is clear, especially of children and animals.
- Don't hurry the learning process or take the unit for granted. Ease into it and become familiar with your new equipment.
- Practice operation of your equipment and its attachments. Completely familiarize yourself and other operators with its operation before using.
- Use a tractor equipped with a Roll Over Protection System (ROPS) and fasten your seat belt prior to starting engine.
- The manufacturer does not recommend usage of tractor with ROPS removed.
- Move tractor wheels to the widest recommended settings to increase stability.
- Securely attach to towing unit. Use a high strength, appropriately sized hitch pin with a mechanical retainer and attach safety chain.
- Do not allow anyone to stand between the tongue or hitch and the towing vehicle when backing up to the equipment.
- Do not use the unit until you are sure that the area is clear, especially of children and animals.

## Important Safety Information



### During Operation

- Children should not be allowed on the machine.
- Clear the area of small children and bystanders before moving the machine.
- If using a towing unit, securely attach implement by using a hardened 3/4" pin, a metal retainer, and safety chains if required. Shift towing unit to a lower gear before going down steep downgrades, thus using the engine as a retarding force. Keep towing vehicle in gear at all times. Slow down for corners and rough terrain.
- Make sure you are in compliance with all local and state regulations regarding transporting equipment on public roads and highways. Lights and slow moving signs must be clean and visible by overtaking or oncoming traffic when machine is transported.
- Beware of bystanders, **particularly children!** Always look around to make sure that it is safe to start the engine of the towing vehicle or move the unit. This is particularly important with higher noise levels and quiet cabs, as you may not hear people shouting.
- **NO PASSENGERS ALLOWED!** Do not carry passengers anywhere on, or in, the tractor or equipment, except as required for operation.
- Keep hands and clothing clear of moving parts.
- Do not clean, lubricate or adjust your equipment while it is moving.
- When halting operation, even periodically, set the tractor or towing vehicle brakes, disengage the PTO, shut off the engine and **remove the ignition key.**
- Be especially observant of the operating area and terrain. Watch for holes, rocks or hidden hazards. Always inspect the area prior to operation.
- **DO NOT** operate near the edge of drop-offs or banks.
- **DO NOT** operate on steep slopes as overturns may result.
- Operate up and down (not across) intermediate slopes. Avoid sudden starts and stops.

## Important Safety Information



### Highway and Transport Operations

- Adopt safe driving practices.
- Keep the brake pedals latched together at all times. **Never use independent braking with machine in tow as loss of control and/or upset of unit can result.**
- Always drive at a safe speed relative to local conditions and ensure that your speed is low enough for an emergency stop to be safe and secure. Keep speed at a minimum.
- Reduce speed prior to turns to avoid the risk of overturning.
- Avoid sudden uphill turns on steep slopes.
- Always keep the tractor or towing vehicle in gear to provide engine braking when going downhill. Do not coast.
- Do not drink and drive!
- Comply with state and local laws governing highway safety and movement of farm machinery on public roads.
- Use approved accessory lighting, flags and necessary warning devices to protect operators of other vehicles on the highway during daylight and nighttime transport. Various safety lights and devices are available from your dealer.
- The use of flashing amber lights is acceptable in most localities. However, some localities prohibit their use. Local laws should be checked for all highway and marking requirements.
- When driving the tractor and equipment on the road or highway under 40 kph (20 mph) at night or during the day, use the amber warning lights and a slow moving vehicle (SMV) identification emblem.
- Plan your route to avoid heavy traffic.
- Be a safe and courteous driver. Always yield to oncoming traffic in all situations, including narrow bridges, intersections, etc.
- Be observant of bridge loading ratings. Do not cross bridges rated at lower than the gross weight at which you are operating.
- Watch for obstructions overhead and to the side while transporting.
- Always operate in a position to provide maximum visibility at all times. Make allowances for increased length and weight of the equipment when making turns, stopping the unit, etc.
- Pick the most level route when transporting across fields. Avoid the edges of ditches or gullies and steep hillsides.
- Be extra careful when working in inclines.

## Important Safety Information



### Highway and Transport Operations

- Maneuver the tractor or towing vehicle at safe speeds.
- Avoid overhead wires or other obstacles. Contact with overhead lines could cause serious injury or death.
- Avoid loose fill, rocks and holes, they can be dangerous for equipment operation or movement.
- Allow for unit length when making turns,
- Operate the towing vehicle from the operator's seat only.
- Never stand alongside of unit with engine running or attempt to start engine and/or operate machine while standing alongside of unit.
- Never leave running equipment attachments unattended.
- As a precaution, always recheck the hardware on equipment following every 100 hours of operation. Correct all problems. Follow the maintenance safety procedures.

## PTO Driveline Instructions

### Instructions for Installing a PTO Driveline:

1. Begin by parking the tractor and implement on a level, solid surface. Attach the implement to the tractor's hitch arms, upper and lower. Adjust the tractor's 3-point hitch so that the tractor's output shaft is level with the implement's input shaft.
2. Leave the tractor in gear, shut off the tractor engine, remove the key and set the park brake. Block the implement to prevent it from falling over or shifting.
3. Slide the inner yoke of the PTO shaft 'A' (implement end) onto the input shaft of the implement. Make sure the yoke is securely locked in place.
4. Slide the outer yoke of the PTO shaft 'B' (tractor end) onto the tractor input shaft. Make sure the yoke is securely locked in place.
5. Because of differences in tractor 3-point arms and implements, it may be necessary to shorten the PTO Driveline. See next page for "**Instructions for Shortening a PTO Driveline**".
6. Check that the PTO Driveline yokes are securely attached to the tractor and implement before operating. PTO Drivelines not attached properly can cause serious injury or death!
7. If your PTO Driveline shields are equipped with chains, secure the chain to the tractor and or implement to prevent the shield from rotating.
8. Before starting tractor and engaging the PTO Driveline, make certain there are no people or animals between tractor and implement. Rotating PTO Drivelines can cause serious injury or death!

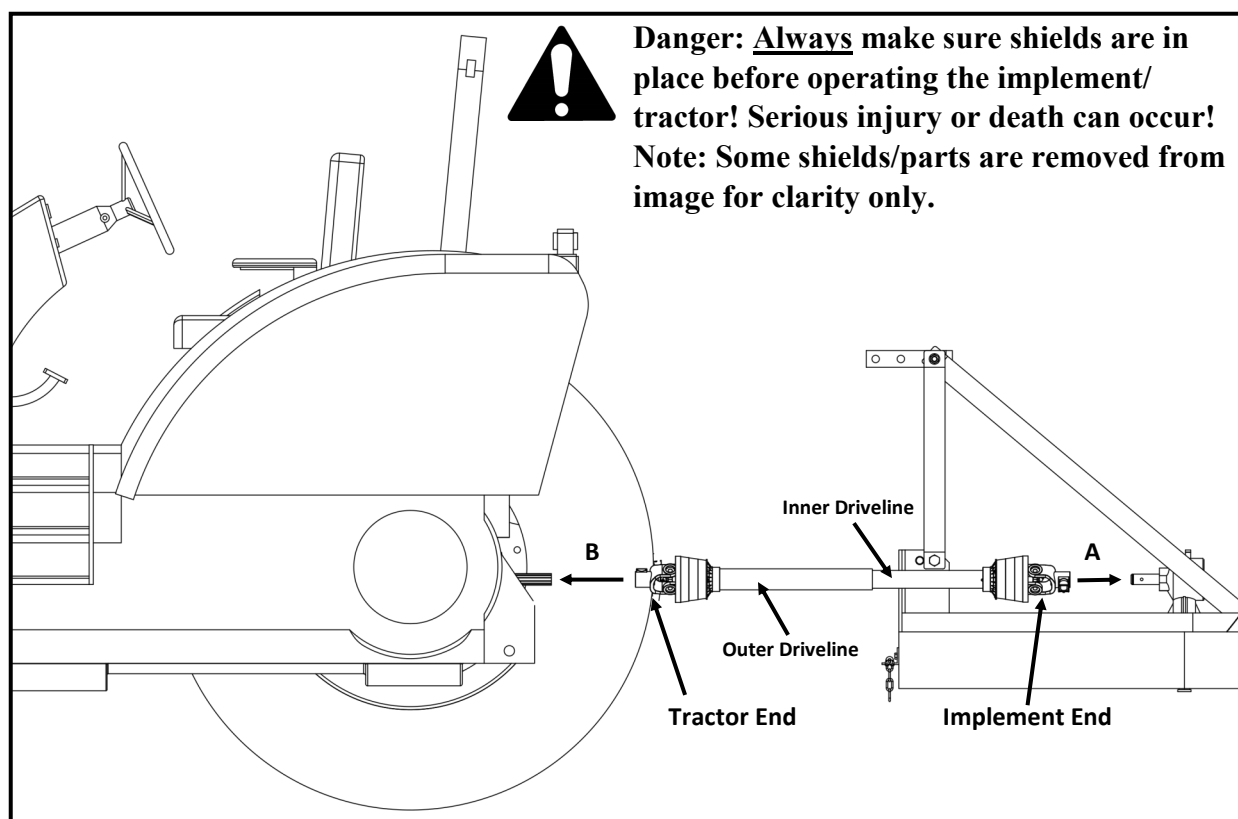

## PTO Driveline Instructions

### Instructions for Shortening a PTO Driveline:



**Note:** If you are not confident modifying the PTO Driveline, you should contact a Qualified Professional.

1. Separate the inner and outer PTO Drivelines. Leave separated at this time.
2. Attach the outer PTO Driveline to the tractor implement input shaft and inner PTO driveline to the implement input shaft.
3. With the drivelines parallel to one another, measure 1" (dim. 'B') back from the outer PTO Driveline shield (see fig. 2) and make a mark on the inner PTO Driveline.
4. Measure 1" (dim 'B') back from the inner PTO Driveline shield (see fig. 2) and make a mark on the outer PTO Driveline.
5. Remove the drivelines from the tractor and implement.
6. Measure from the end of the inner shield to the scribed mark (dim. "C"). Cut the inner shield at that mark. Cut the same amount off the inner shaft (dim. "C1").
7. Measure from the end of the outer shield to the scribed mark (dim. "D"). Cut the outer shield at that mark. Cut the same amount off the inner shaft (dim. "D1").
8. Clean off all burrs from both drivelines.
9. Refer to "Checking PTO Driveline Extended Length" section next.

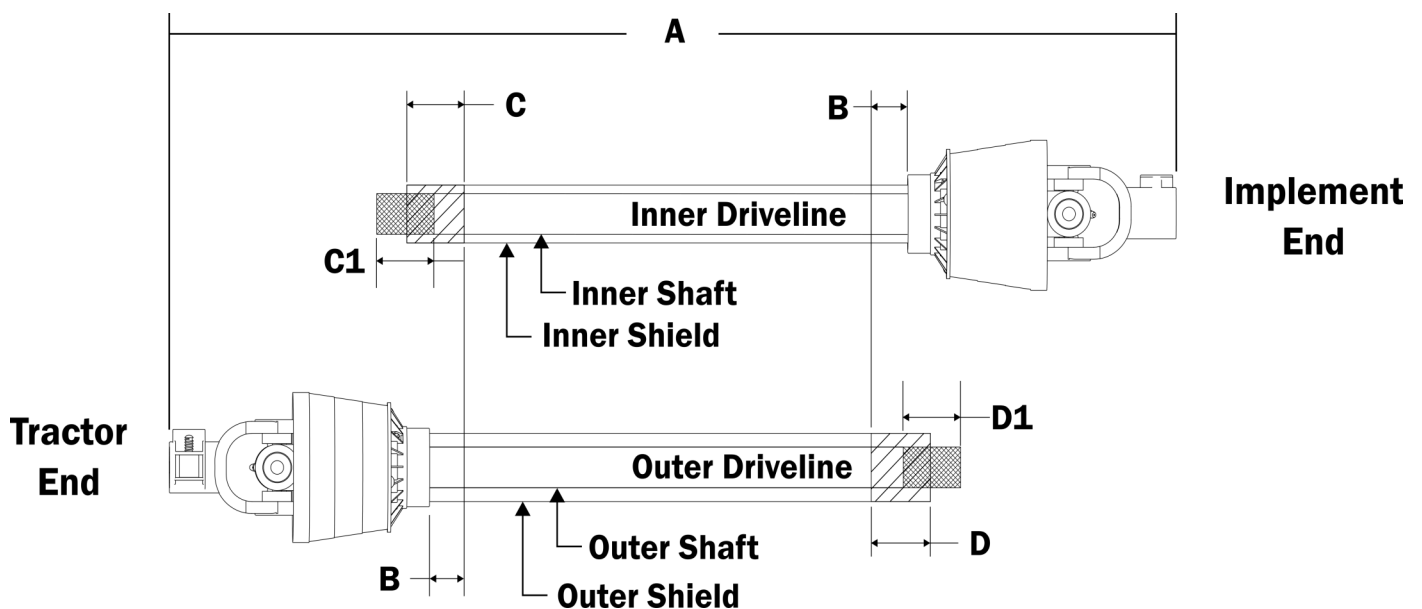

## PTO Driveline Instructions

### Checking PTO Driveline Extended Length:

1. Apply multi-purpose grease to the outside of the inner driveline section. Assemble the outer and inner drivelines.
2. When fully extended, the maximum allowable length must have a minimum overlap of  $\frac{1}{3}$  the free length of the inner and outer sections. Measure and record the maximum extended length for future reference.
3. Attach the outer PTO Driveline to the tractor implement input shaft and inner PTO driveline to the implement input shaft.
4. Pull both yoke ends to make sure they are properly seated on the input shafts. **Warning:** If the drive lines are not properly seated, they can separate from the tractor or implement, causing extensive damage and possibly serious injury or death.
5. Raise and lower the implement to determine the maximum extended length. Make sure the maximum extended length does not exceed the maximum length determined from step 2.

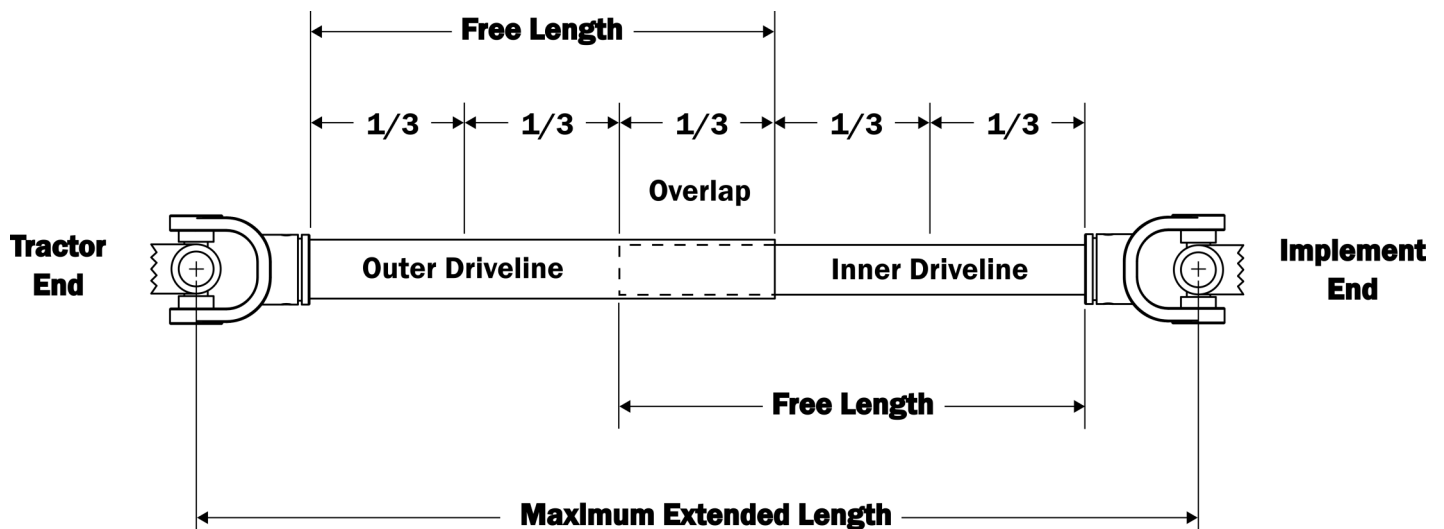

**Danger:** Always make sure shields are in place before operating the implement/tractor! Serious injury or death can occur!

**Note:** Some shields/parts are removed from image for clarity

## PTO Driveline Instructions

### Checking for PTO Driveline Interference:

1. Begin with the PTO Driveline level (0 degrees). Raise the implement at an angle no greater than 25 degrees from level. Check for any interference and the length of the PTO Driveline extended. Do not exceed the maximum extended length!
2. Next lower the PTO Driveline at an angle no greater than 25 degrees from level. Check for any interference and the length of the PTO Driveline extended. Do not exceed the maximum extended length!

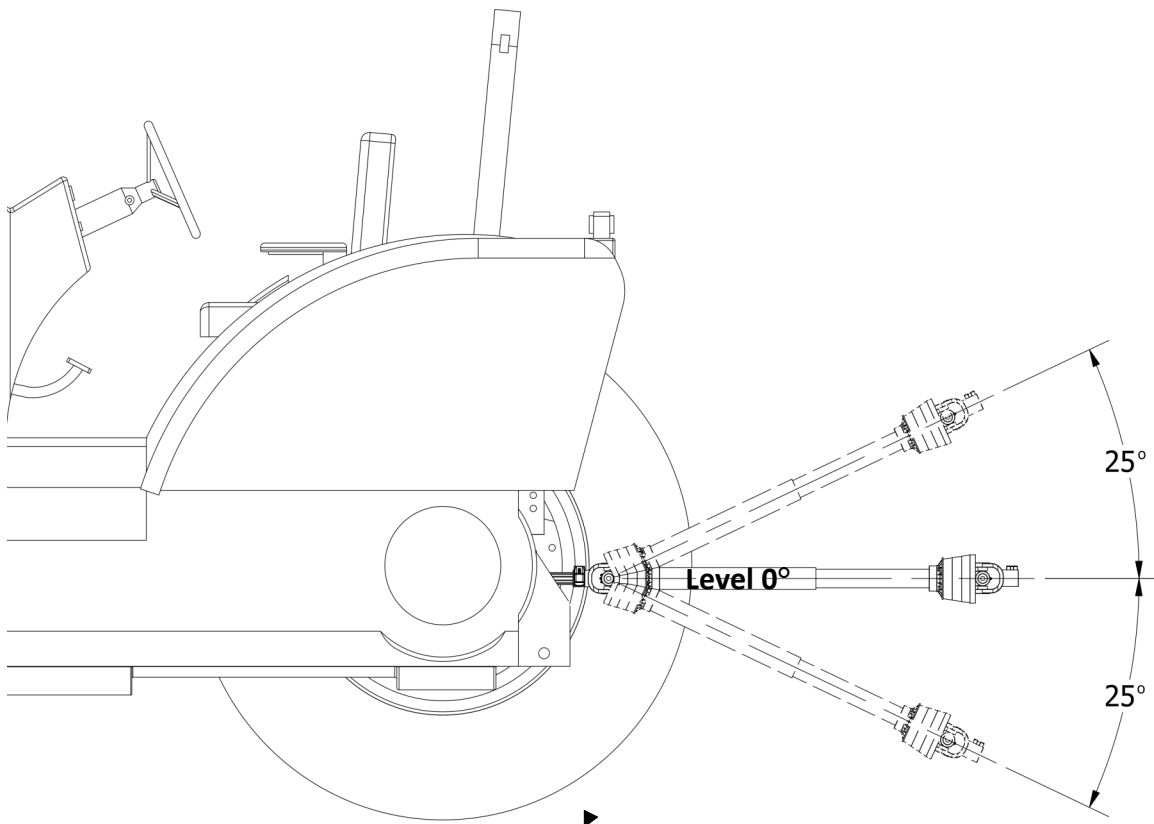

**Danger: Always make sure shields are in place before operating the implement/tractor! Serious injury or death can occur!**

**Note: Some shields/parts are removed from image for clarity**



Scan the QR code below for more detailed information on PTO installation.



## Assembly

The PTO shaft, twine and electrical connections are located in the twine storage compartment (under the lid at front of the baler). The wheels are located inside the bale opener door (at rear of the baler). See “Attaching Wheels” (page 18) for instruction on how to remove wheels from baler chamber.

### Attaching to a tractor:

- It is best to attach the baler to the tractor on a level surface.
- Back the tractor to the baler making sure the tractor lower arms are level with the baler’s lower hitch pins.  
**Caution: Be sure that there are no people and animals between the tractor and the baler when backing.**
- Secure the tractor’s lower arms to the baler’s lower hitch pins with lynch pins.
- Attach the tractor’s top link to the baler’s upper hitch. Adjust the top link so that the baler is level on the ground.
- If baler is in the shipping frame, attach baler to tractor using tractor 3-point, remove bolts securing baler to shipping frame, lift baler, remove and properly discard the shipping frame.

### Connecting Hydraulic Control:

Connect the ring ends of the cables to the tractor battery. The black cable supplies power to the Hydraulic Control (yellow box). The white cable supplies power to the alarm/buzzer. Connect the red wires to the positive and blue wires to the ground. Note: If the Binding Arm is not raised, the alarm will sound. Either raise arm or disconnect the white cable at the quick connect near the machine and re-connect before baling.

Route the cables along the tractor frame so they are protected from damage. Leave enough slack in the cables to prevent stretching and damaging wires when making turns. Cables should be secured to tractor using cable ties. *Note: Replacement Hatch Controller and Buzzer Cord part numbers are listed below.*

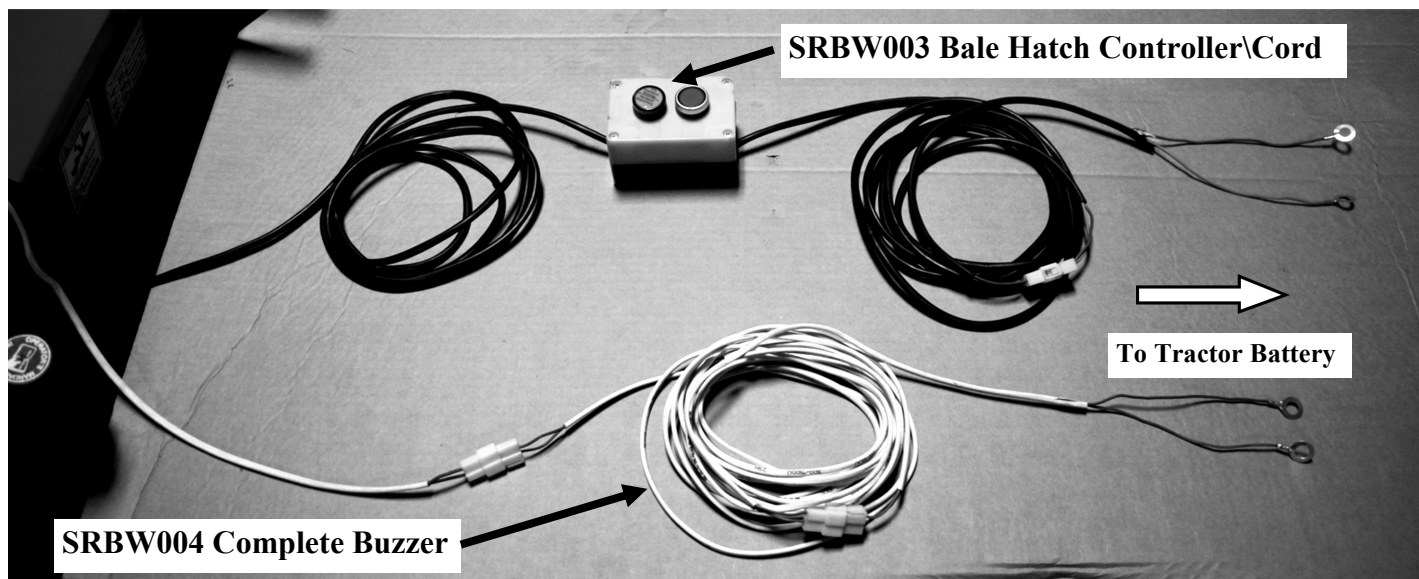

## Assembly

### Attaching wheels:

The baler wheels are stored inside the baler rolling chamber at the rear of the baler for shipping purposes. The rear door is opened by the baler hydraulics.

### Opening rear door:

- **Press and hold** the red button on the controller to activate the hydraulic cylinder to raise the door. **Caution:** Before attempting to open the rear door, make sure that no one is standing near the rear of the baler. Be sure there is ample room behind the baler to open the rear door.
- **Warning:** The rear door remains open as long as the operator presses the red button. Once the red button is released, the rear door will close. Depending on where the flow control handle is set, the door can close very rapidly. **Do not** allow anyone to stand near the rear door until the flow valve handle is in the locked position.
- Locking rear door: rotate the flow control valve handle 90 degrees to the valve body.

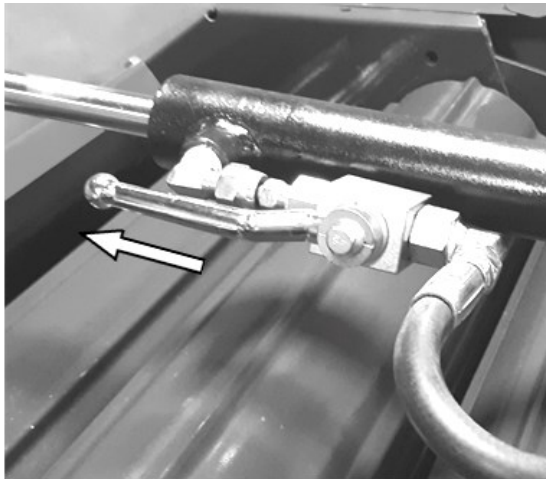

**Flow Control Valve - Open 100%**

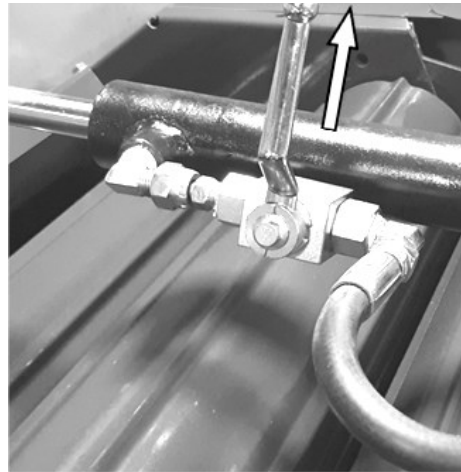

**Flow Control Valve - Locked**

## Assembly

### Attaching wheels:

- Remove the wheels from the baling chamber, unlock the flow control valve and close the rear door.  
**Caution:** Before closing the rear door make sure no one is standing near the rear of the baler.
- Using the tractor 3-point, lift the baler high enough to insert wheels into baler frame.
- Insert the shaft of one wheel assembly on to the baler frame as shown below.
- There are two indents on the shaft. Line up the indent with the bolt hole in baler frame. Thread the bolt until it locks into the indent on the shaft. Tighten the bolt and lock nut. Repeat for the other wheel assembly.
- The wheels can be set in two positions. Choose the position best suited for your application.

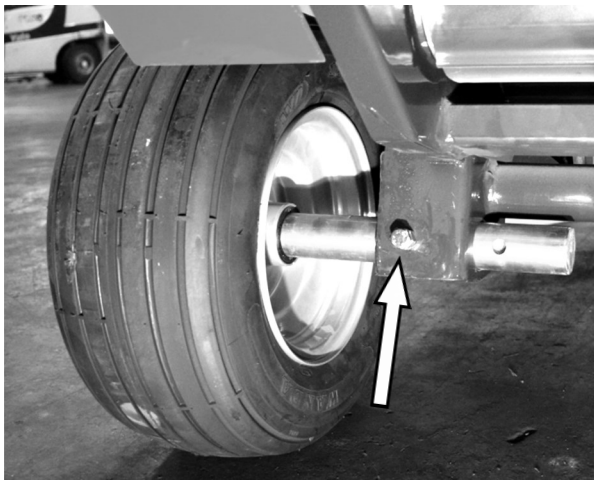

LH Wheel Assembly

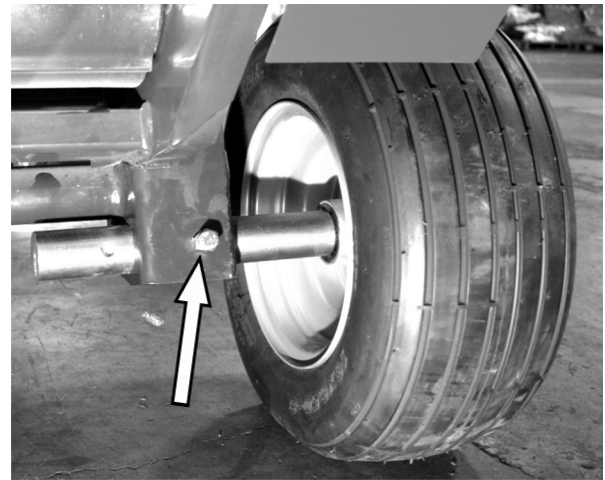

RH Wheel Assembly

## Assembly

### Threading the twine:

The twine is located in the twine storage compartment of the baler (located in the front of the baler). This baler can handle up to two rolls of twine at a time.

If using two rolls of twine, find the leading edge of roll 2 (usually found under the twine's label). Next find the end of roll 1 and join the two rolls with a knot. Be sure to tie a knot small enough to not jam the mechanism or break the twine.

### Routing twine:

**Step 1:** Feed the leading end of twine through the "Twine Guide".

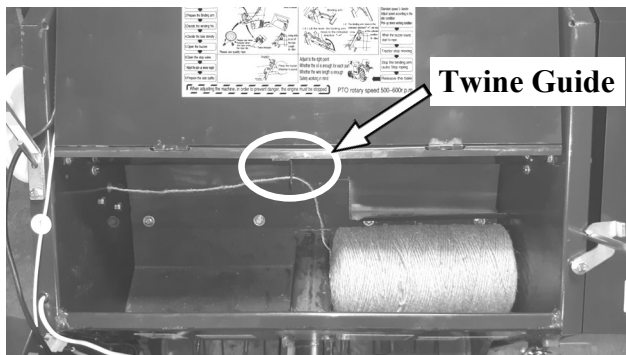

**Single Roll Routing**

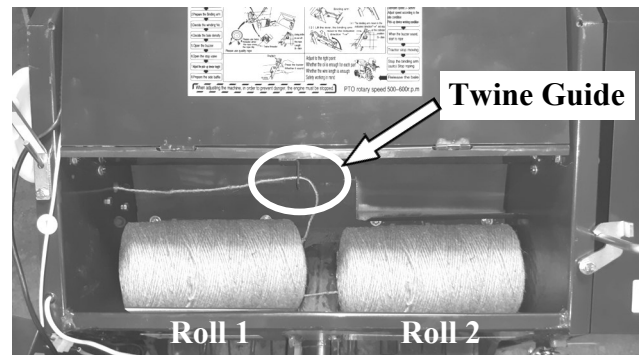

**Double Roll Routing**

**NOTE:** Part Number for replacement twine, TG0800 Twine 8500' - SRB-870.

**Step 2:** Feed twine through the RH wall of twine storage compartment as shown below.



## Assembly

**Step 3:** Once the twine is thru the RH storage compartment wall, feed twine thru the tensioner and front twine guide. Wrap the twine around the pulley once as shown in the small or large slot depending on application. See “Bale Density” for selecting proper slot.

Feed twine through the rear guide and through the opening in the RH side of baler wall.

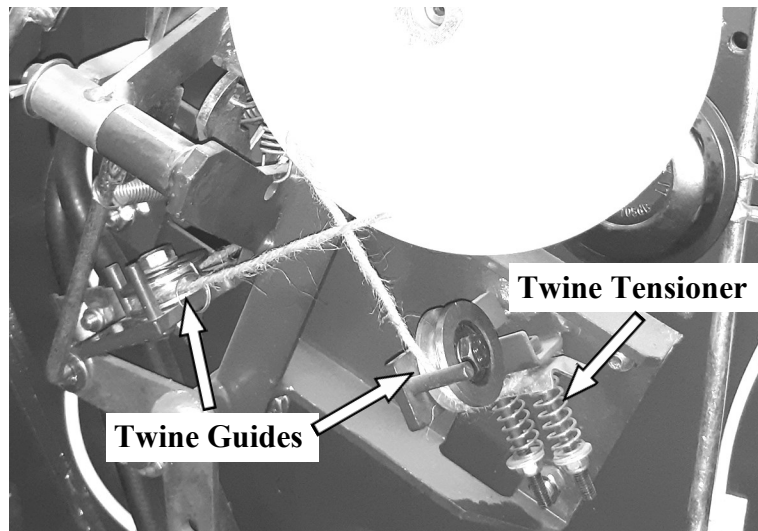

**Step 4:** Feed the twine thru the lower guide, upper guide and lastly the Binding Arm Tensioner. Leave approximately 12” of twine hanging from the tip of the Binding Arm. Do not allow the twine to come in contact with the chamber rollers. The twine could be pulled into the chamber and trigger the bale wrapping mechanism or become tangled in the rollers.

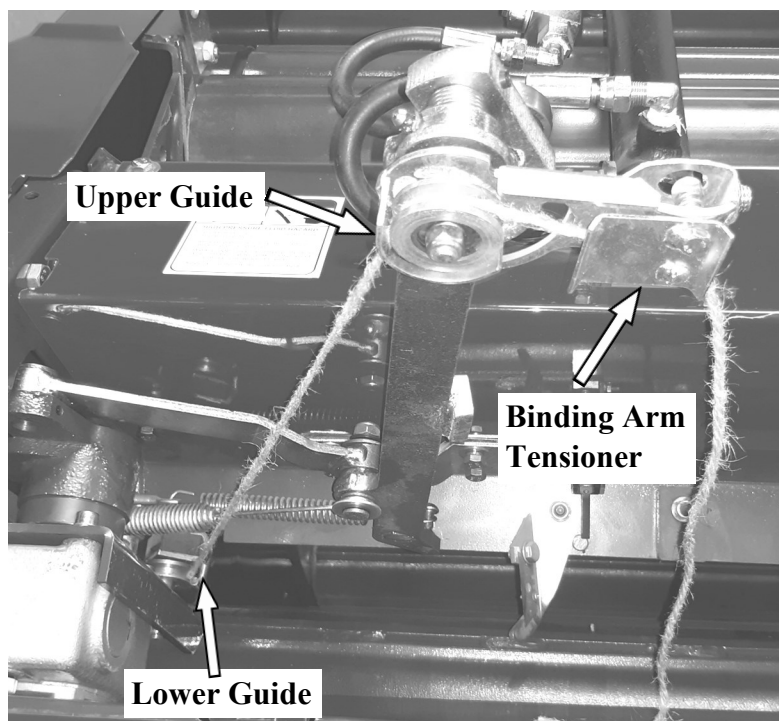

## Operating Instructions

### Initial Preparation for Baling:

The pick-up handle must be moved to the “Operation” position prior to baling. This will lower the pick-up. Pull down on handle, move the latch to the right and allow the handle to move up. NOTE: Only lower the pick-up when ready to begin baling. When transporting to and from the field, raise the pick-up to prevent damage to the machine.



**Transport Position**



**Operation Position**

Use the height adjustment chain to raise or lower the height of the pick-up so that the tines are approximately 1” from the ground. This measurement is for reference only. The operator should run the machine for a period of time to determine if the pick-up height should be higher or lower depending on the height and type of material baled. Shorter grass may require a lower setting to properly pick-up material. Longer grass may require a higher setting to prevent clumping of material.

**Note: For cleaner material and longer life of tines, avoid continuous contact with the ground.**



**Height Adjustment Chain**

## Operating Instructions

### Baling:

- Line up tractor with the first windrow. Engage the tractor's PTO and begin baling.
- Slowly drive over the windrow. It is recommended to drive the tractor 2-3 miles per hour for best results. However, speed can depend on type of material baling, field conditions and size of windrow.
- Continuously monitor the pick-up. If material is gathering up in front of the pick-up, slow down or stop tractor to allow the baler to catch up and pick up the excess material.
- Monitor the bale chamber indicator located on the RH top of the baler. This is a visual indicator of bale chamber capacity. The rod will begin to move up when the bale chamber is approximately 3/4 full
- The alarm will sound when the bale chamber is full. Stop the tractor. The binding arm will automatically begin to wrap the twine around the bale. When the winding process finishes, the binding arm will cut the twine. The bale is now ready to be ejected from the baler.
- Press and hold the red button on the hydraulic control box. The rear door will raise and eject the bale. Once the bale is clear of the baler, release the button to lower the door and continue baling. **Caution: Do not allow people near the rear of the machine when raising or lowering the rear door.**

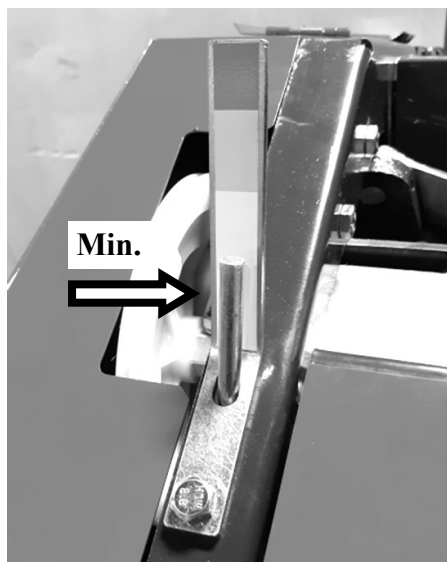

**Bale Chamber Indicator at min.**

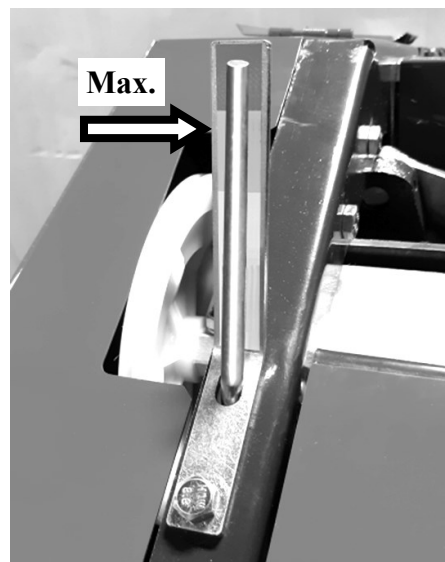

**Bale Chamber Indicator at max.**

## Adjustments

### Bale Density:

- Adjust bale density according to the tractor size, field conditions and type of material baled.
- To change positions of the Connecting Rod, remove the hairpin clip and move to next hole up or down.
- The higher the position of the Connecting Rod, the lower the density of bales produced. This setting is for hay or straw that has a high moisture content.
- The lower the position of the Connecting Rod, the higher the density of bales produced. This setting is for hay or straw that is dry or has a low moisture content.
- If the bale density is not achieved, move the Connecting Rod to the next position (higher or lower), run the machine and check density again. Move only one position at a time until the correct density is achieved.

**Caution:** Be aware of the electrical cable attached to the Connecting Rod. When changing positions, be sure not to damage or stretch the cable.

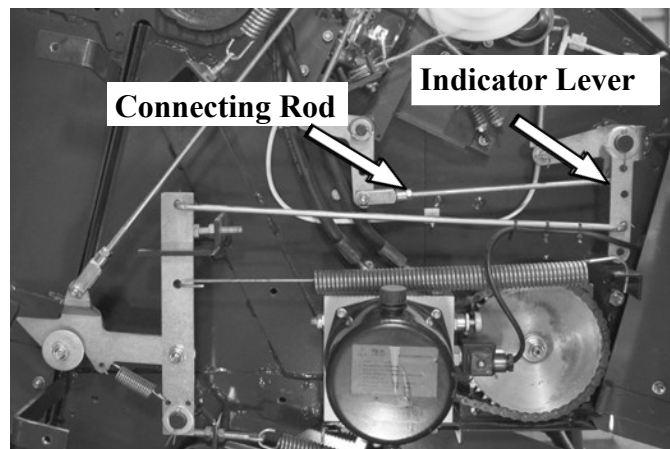

### Twine Tension:

- There are two places on the machine to adjust twine tension. (See below)
- There has be sufficient tension on the twine so that it stays on the guides and so that it is cut at the end of the baling operation.
- If the tension is too tight it will not properly feed through the guides possibly breaking the twine.
- Adjust the twine tension before each use for optimal performance.

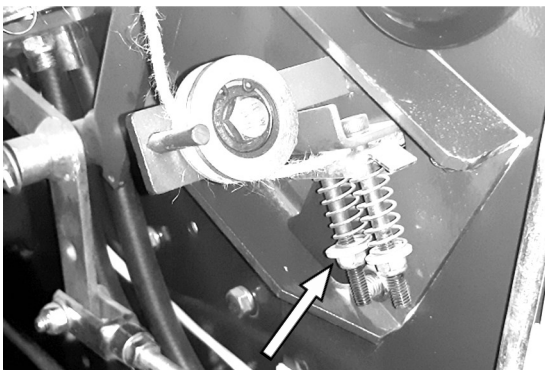

Twine Tensioner #1 (RH inside cover)



Twine Tensioner #2 (end of binding arm)

## Adjustments

### Number of Wraps per Bale:

- The number of wraps per bale is controlled by the pulley located under the front RH side cover of the machine.
- There are two positions on the pulley. The large slot will wrap the bale approximately 11 times. The small slot will wrap the bale approximately 8 times.
- If the bales are very dry, bales are to be handled more or if the material baled is short, use the larger diameter slot in the pulley for more wraps.
- The smaller pulley should be used for longer hay.

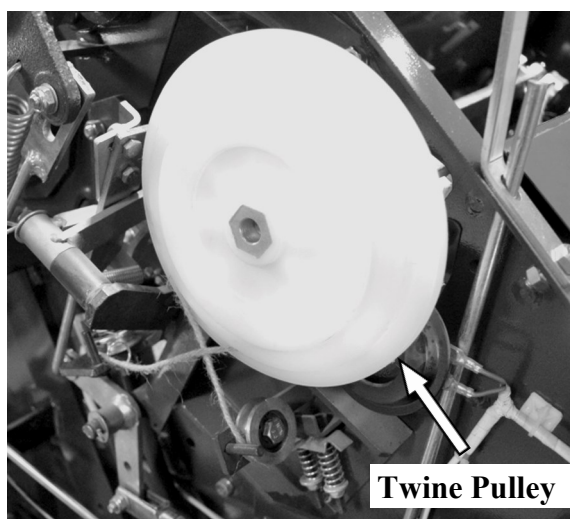

### Pick-up Height:

- Lower the pick-up by pushing down on the lever, rotate the lock to the right and allow the handle to move up.
- Adjust height of pick-up using the pick-up chain.
- Under normal operating conditions, the pick-up tines should be approximately 1 inch from the ground.
- If the field contains rocks or is uneven, set the tines higher to prevent damage to pick-up and tines.
- Lower the pick-up for lighter, shorter materials baled.
- When transporting the baler, make sure the pick-up is in the transport position or damage could occur to baler.

## Adjustments

### Rear Door Closing Rate:

- If the flow control valve handle is parallel to the control valve body it is fully open. There is no restriction of flow. **Note: In the fully open position, the rear door will close rapidly.** Anyone standing under or near the door could be seriously injured. The rear door is extremely heavy!
- To slow the rear door when closing, move the handle clock-wise to achieve the desired speed.
- There are times when the operator will need to lock the flow control valve such as for maintenance. To lock the cylinder, rotate the handle clock-wise until it stops. Remember to unlock flow control valve before continuing operation.

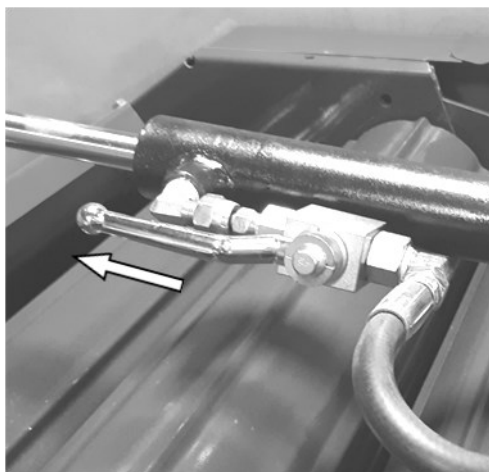

Flow Control Valve - Open 100%

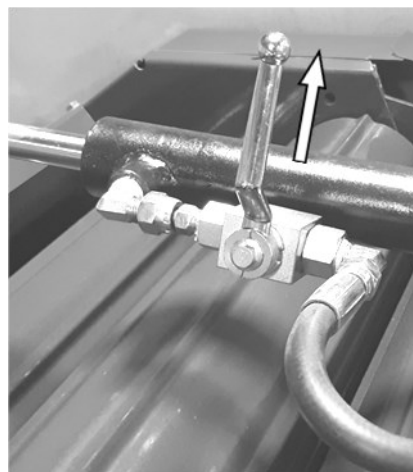

Flow Control Valve - Locked

### Resetting Twine Arm:

- It may be necessary at times to reset the Twine Arm.
- Push the Release, pull up on the short arm and lift the Binding Arm to about 90 degrees.
- If the short arm won't come up, open RH side cover and rotate the Twine Pulley clock-wise until the short arm releases.

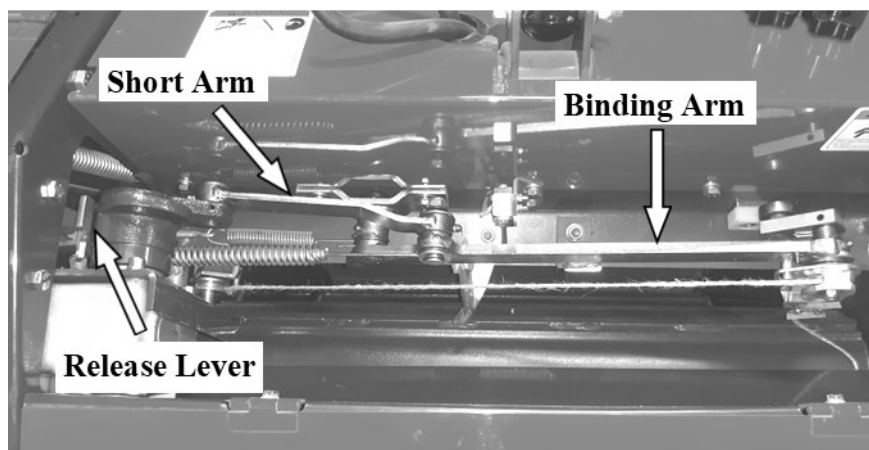

## Adjustments

### After Operation:

Follow the guidelines listed below after baling.

- Store the baler under a shelter or in a building out of the weather.
- If left attached to the tractor, lower the baler so that the wheels are touching the ground. Never leave any implement raised.
- If removing the implement: Take the pressure off the top pin by raising or lowering the tractor 3-point and remove top link pin. Before disconnecting the lower hitch, pull the pin on the baler parking stand, lower the stand and insert pin. The baler may be raised or lowered by the 3-point to set the baler parking stand.
- Be sure to chock the baler's tires to prevent it from rolling and injuring bystanders or damaging equipment.
- Inspect the baler for damage. If any damage is found, make the necessary repairs to keep the baler in optimal operating condition.
- Inspect the baler for loose hardware. Tighten to proper torque specifications.
- Perform any daily maintenance according to "Maintenance Schedule" before operating again.

### Recommendations for Consistent Bales:

- Generally a slower the tractor speed will result in denser bales. It is recommended to begin with 2-3 miles per hour. Adjust speed according to field conditions.
- Windrows should be 28-32 inches wide with a height of 12-16 for best results. Uniform windrows will produce a more consistent weight of bales and there will be fewer issues during the baling. Many baling issues are related to material that is too short or too dry.
- The material should be baled when it is 1-3 feet tall and approximate moisture content of 15%.
- Material that is extremely dry will result in bales that are under weight, inconsistent in size and the twine will not wrap properly.
- Consistent bales are achieved when the material is evenly distributed across the full width of the baler pick-up.



**Caution:** The baler must be lifted off the ground before turning at the end of a windrow. If the baler is not lifted, damage can occur to the tires and wheels. When lifting the baler, lift it high enough to clear the ground by a few inches. Be careful not to lift the baler so high that it puts the PTO in a bind. Extreme PTO angles can cause damage to the PTO and the baler gear box.

## Adjustments

### Roller Chain:

Roller chains will stretch during normal usage, especially during initial use of the baler. This is normal for any type of roller chain and is to be expected. Performing regular maintenance will extend the life of the chains and sprockets. A loose chain will cause premature wear of sprockets and will affect the performance of the baler. Check tension of chains and tighten when necessary.

The main drive chain (LH cover) is adjusted by tightening or loosening the tensioner springs and by adjusting the tension plate. The manufacturer recommends Spring "A" to be set at  $1\text{-}7/16"$  and Spring "B" set at  $1\text{-}1/2"$  for optimal performance. The tensioner plate should deflect the joint chain by approximately  $1/8"$ . Adjust as needed.

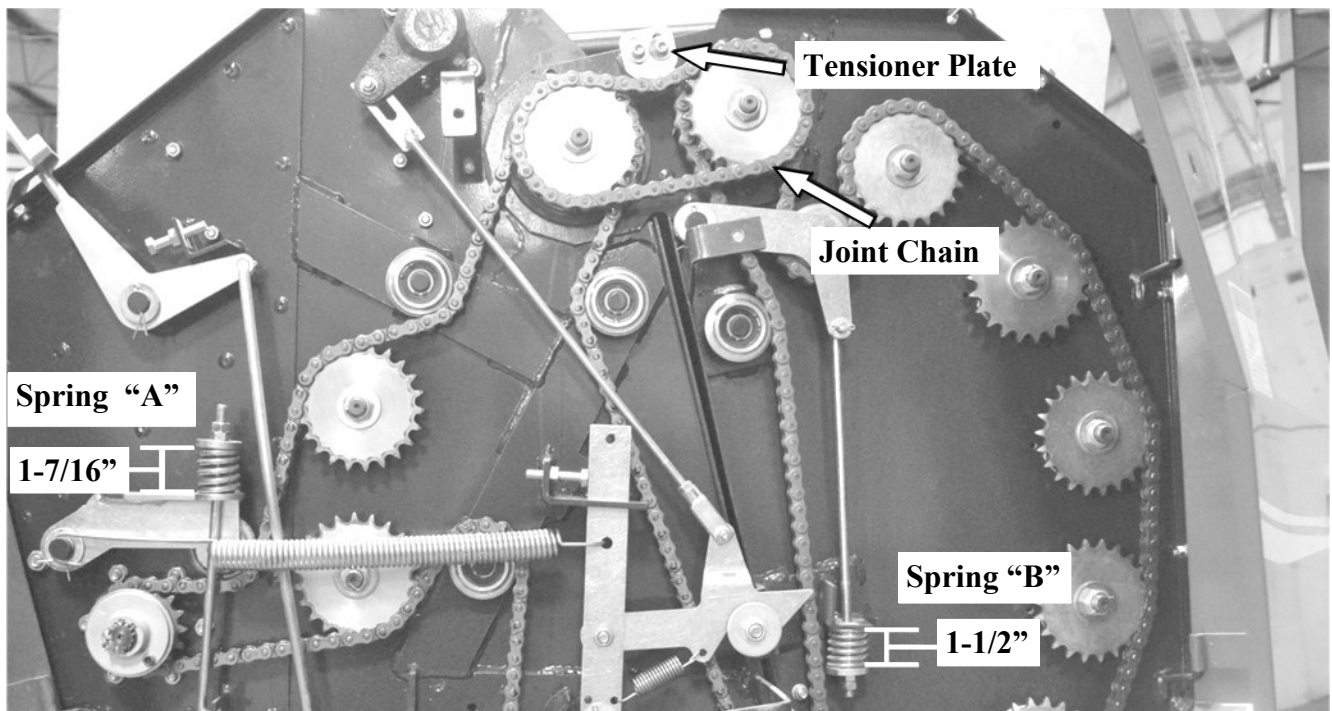

Adjust the hydraulic power pack drive chain by loosening the power pack hardware and moving the position of the hydraulic power pack. Proper chain deflection for the hydraulic power pack chain is approximately  $3/16"$ .

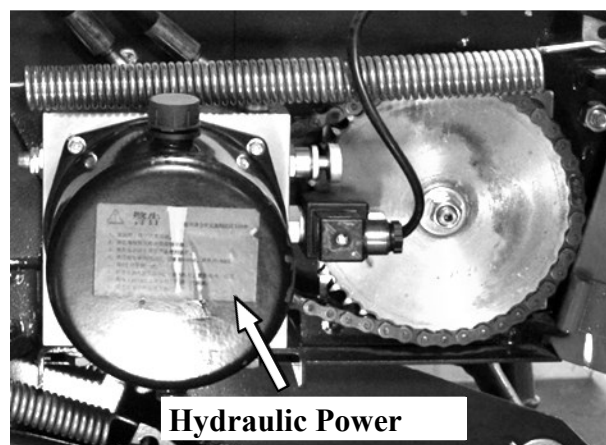

## Adjustments

### Roller Chain continued:

#### Pick-up drive chain

Remove pick-up drive cover by removing the (3) threaded knobs.  
Adjust the pick-up drive chain tension by changing the position of the tension pulley.  
Chain deflection should be set at approximately 1/8".

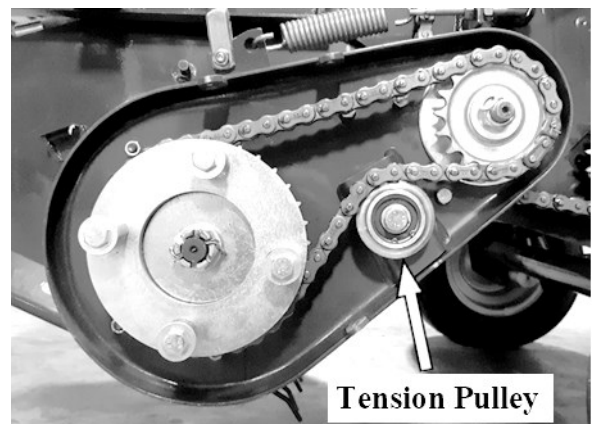
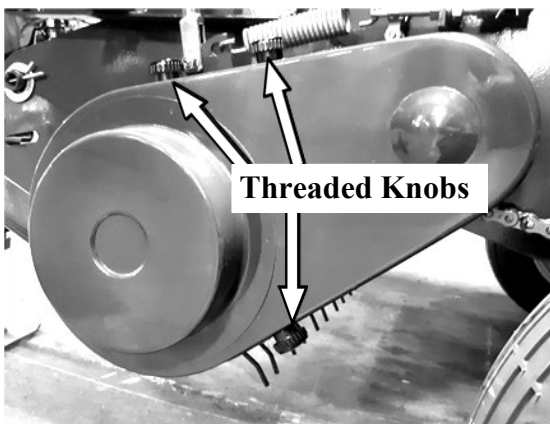

#### Pick-up drive slip clutch

The pick-up drive comes standard with a slip clutch to prevent damage to the baler. If the pick-up drive hits an object and can not turn, the clutch will slip to prevent damage to the baler.

The correct setting is approximately 1". Adjust tension if under normal circumstances there is excessive slipping. If slipping continues after adjustment, the friction discs should be changed.

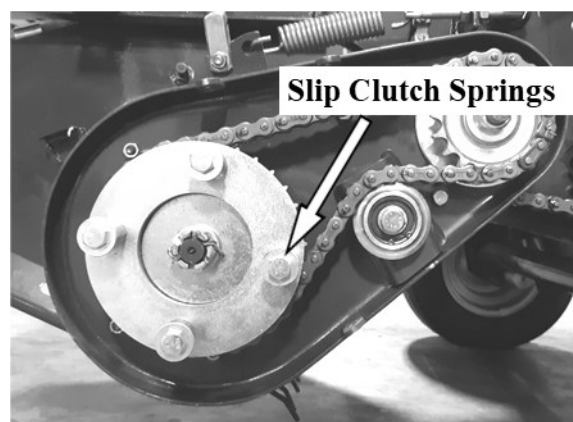

## Adjustments

### Pick-up Suspension:

The pick-up suspension is supported by springs on both sides of the baler. Check the spring with the pick-up in the working position. The correct length of the spring is 1-7/8". Be sure to check both springs. Adjustment to the springs is made by loosening or tightening the nuts on the rod.

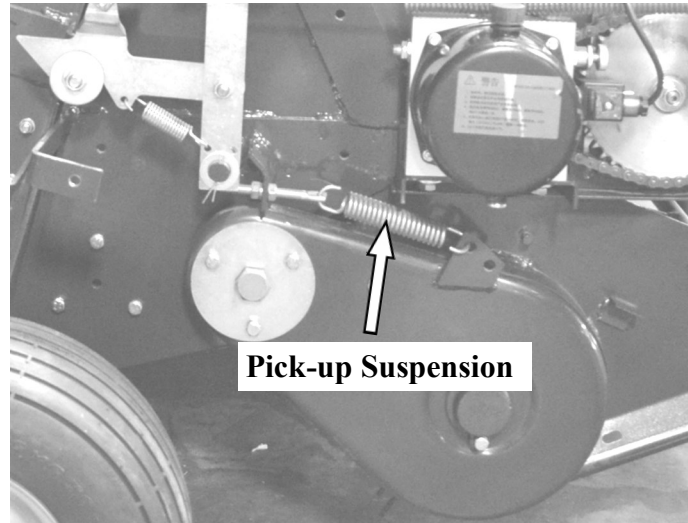

### Twine Tension:

- Check the tension on the twine tensioner springs prior to baling.
- There has to be sufficient tension on the twine so that it stays on the guides and is cut at the end of the baling operation.
- If the tension is too tight it will not properly feed through the guides possibly breaking the twine.
- The springs are adjusted by tightening or loosening the nuts.

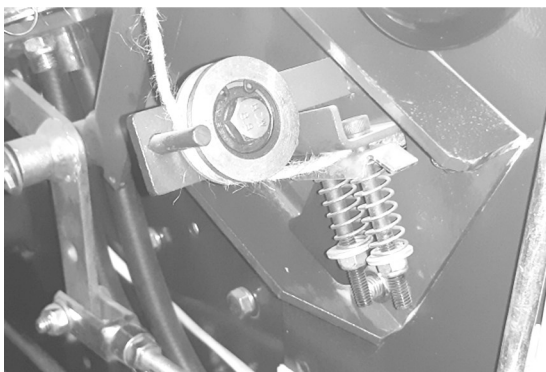

Twine Tensioner 1 (under RH side cover)

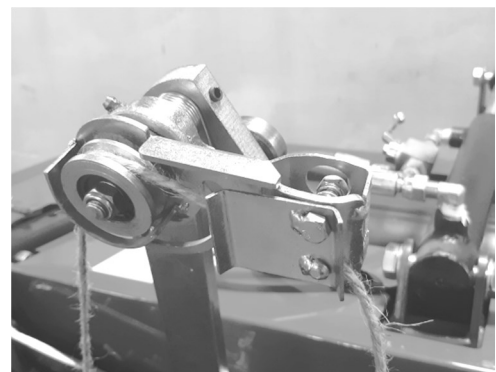

Twine Tensioner 2 (end of binding arm)

## Adjustments

### Twine Cutting Blade:

Replace the blade as needed. Loosen the hardware holding the blade. Remove blade, replace with new one and tighten hardware. Properly dispose of old blade.

**Caution: Blades are sharp. Handle with care when replacing and disposing of old blades.**

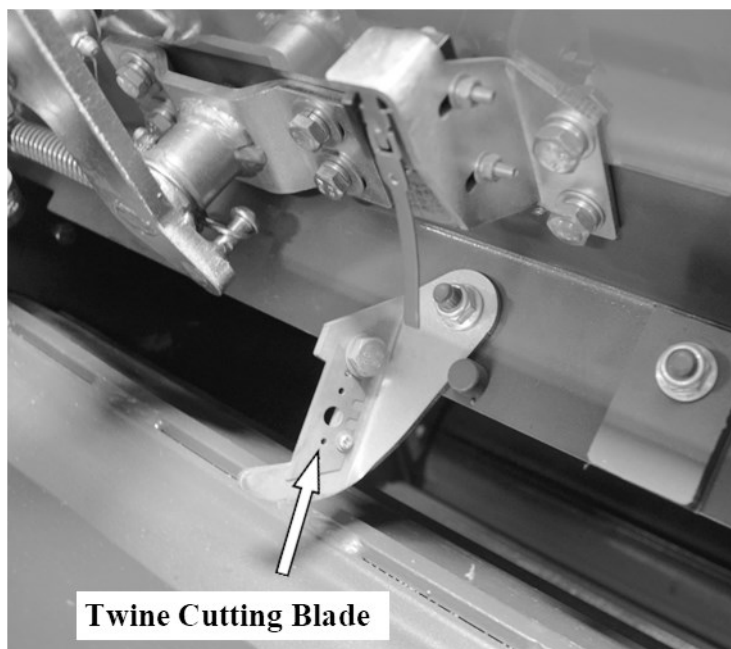

# Maintenance

## Safety:

- Any maintenance is to be done with tractor engine off, baler not running.
- Wear protective gear when servicing the machine, gloves, eye protection, etc.
- It is best to perform maintenance with the machine on a level, solid surface.

Action required		Interval			Specifications
		As needed	Prior to each use	100 Hrs. or Seasonal	
<b>Lubrication</b>					
Gearbox	Replace oil			X	Gear oil: SAE 90
Binding Arm Gearbox	Replace oil			X	Gear oil: SAE 90 Note: Gearbox must be removed to service.
Hydraulic Pump	Replace oil			X	15W40, 1.8 qt.
Drive shaft	Grease	X	X		No. 3 grease
Binding arms and base	Grease	X	X		No. 3 grease
Actuator Arm	Grease	X	X		No. 3 grease
Link & Tension Arm Pivots	Lubricate	X	X		Penetrating chain/cable spray lubricant
Rear Door Pivot	Lubricate	X	X		Penetrating chain/cable spray lubricant
Roller Chains	Lubricate	X	X		Penetrating chain/cable spray lubricant
PTO	Lubricate	X	X		Penetrating chain/cable spray lubricant
<b>General Maintenance</b>					
Hardware	Inspect	X	X		Tighten loose hardware to proper torque values
Roller Chains	Inspect	X	X		Tighten/replace as necessary
Shear Bolt	Inspect				Replace as needed
Check air pressure, tires	Inspect for correct PSI	X	X		Max. 28 psi
Electrical Wiring	Inspect	X			Repair/replace
Cleaning		X			Remove dirt and debris

# Maintenance Schedule

## Lubrication Points

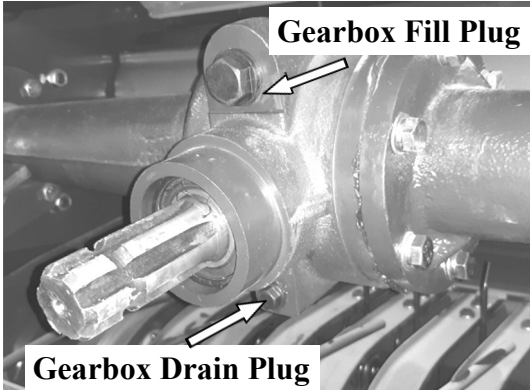

**Gearbox**

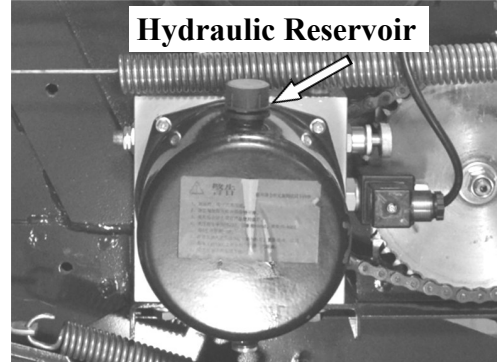

**Hydraulic Pump**

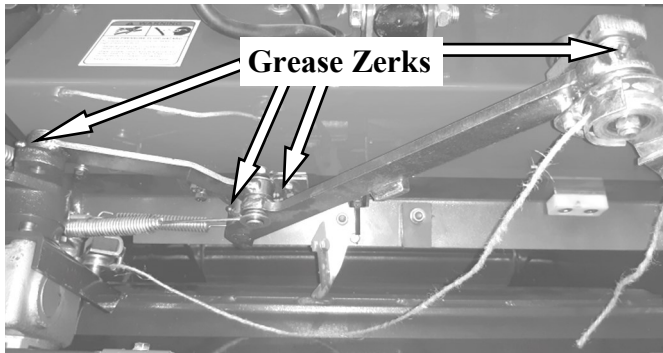

**Binding Arm**

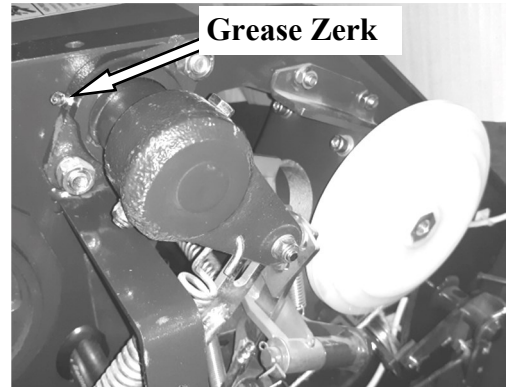

**Actuator Arm - both sides**

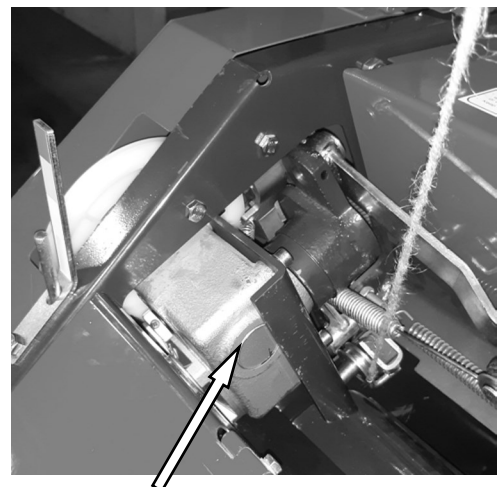
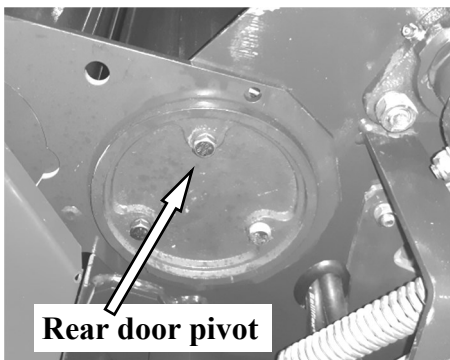

**Binding Arm Gearbox**

# Maintenance Schedule

## Lubrication Points (continued)

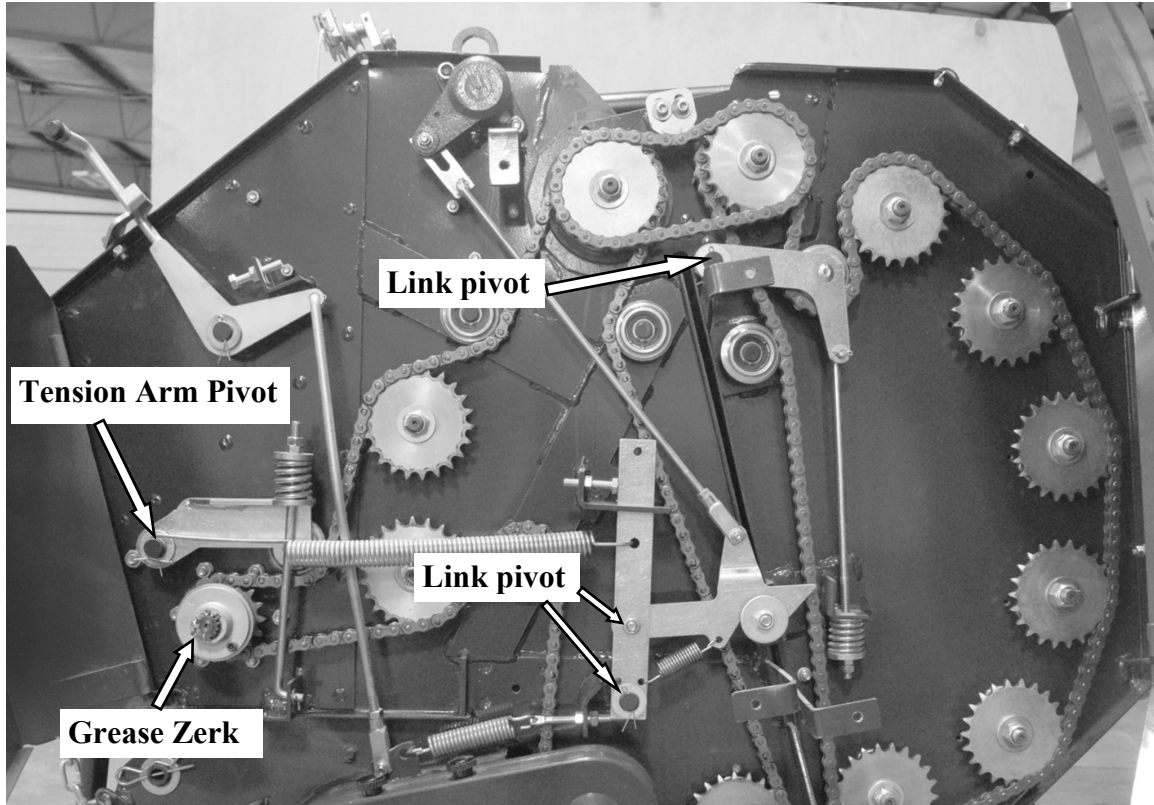

**Pivots and Roller Chain**

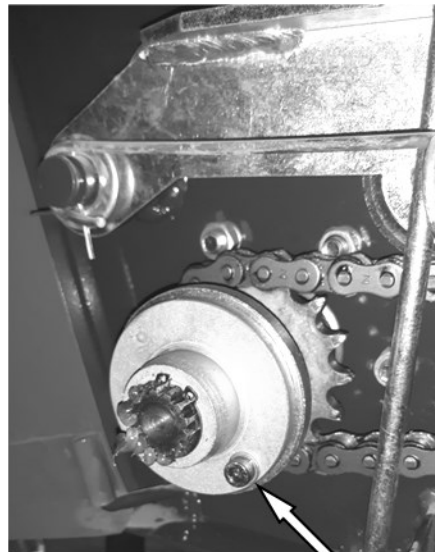

**Shear Bolt**

**NOTE: On some machines the drive pulley has two holes. If your machine has two holes, DO NOT USE TWO SHEAR BOLTS! Only one shear bolt is required to function properly. Two shear bolts will cause**

## Trouble Shooting



### Caution:

When the machine is raised for maintenance or inspection, lock the hydraulic circuit or the tractor to prevent machine falling.

Serious injury or death can occur. Always perform inspection or maintenance on solid ground, preferably concrete.

Never inspect or perform maintenance on uneven surface or soft ground. Stop the tractor engine, disengage PTO and wait for all moving parts to stop before inspection or maintenance.

Lock rear gate by closing stop valve to prevent falling when inspecting or during maintenance.

### Trouble Shooting Pick-Up

#### Trouble Shooting Pick-Up

Fault	Possible Cause	Possible Remedy
<b>Abnormal Noise</b>	Broken Twine	Tine replacement
	Broken rotor flush	Rotor flush replacement
	Winding of hay or twine	Remove winding material
	Excessive wear, cam roller bearing	Replace cam roller bearing
	Insufficient V belt tension	Adjust V belt tension or replace if belt is stretched excessively
<b>Material not picked up cleanly</b>	Wrong pick-up setting	Adjustment in accordance with "3-2-1 adjustment pick-up height from ground"
	Excessive speed	Reduce working speed
	Breakage of tine	Replace tines

# Torque Specifications

Torque Specifications for Common Bolt Sizes															
Inches		Bolt Head Identification						Metric		Bolt Head Identification					
										5.8		8.8		10.9	
Bolt size (inches)	Thread pitch	Grade 2		Grade 5		Grade 8		Class 5.8		Class 8.8		Class 10.9			
		N.m	ft-lb	N.m	ft-lb	N.m	ft-lb	N.m	ft-lb	N.m	ft-lb	N.m	ft-lb		
1/4"	20	7	5	11	8	16	12	M5	0.08	4	3	6	4	9	7
1/4"	28	8	6	13	10	19	14	M6	1	6	4	10	7	15	11
5/16"	18	15	11	24	17	33	25	M8	1.25	16	12	25	18	36	27
5/16"	24	17	13	26	19	37	27	M8	1	17	13	26	19	38	28
3/8"	16	27	20	42	31	59	44	M10	1.5	31	23	48	35	71	52
3/8"	24	31	23	47	35	67	49	M10	1.25	33	24	51	38	75	55
7/16"	14	43	32	67	49	95	70	M10	1	35	26	53	39	78	58
7/16"	20	48	36	75	55	106	78	M12	1.75	54	40	84	62	123	91
1/2"	13	66	48	102	75	144	106	M12	1.5	56	41	87	64	128	94
1/2"	20	75	55	115	85	163	120	M12	1.25	59	44	90	66	133	98
9/16"	12	95	70	147	109	208	154	M14	2	84	62	133	98	195	144
9/16"	18	106	79	164	121	232	171	M14	1.5	94	69	142	105	209	154
5/8"	11	132	97	203	150	287	212	M16	2	131	97	206	152	302	223
5/8"	18	149	110	230	170	325	240	M16	1.5	141	104	218	161	320	236
3/4"	10	233	172	361	266	509	376	M18	2.5	181	133	295	218	421	310
3/4"	16	261	192	403	297	569	420	M18	2	196	145	311	229	443	327
7/8"	9	226	167	582	430	822	606	M18	1.5	203	150	327	241	465	343
7/8"	14	249	184	642	473	906	668	M20	2.5	256	189	415	306	592	437
1"	8	339	250	873	644	1232	909	M20	1.5	288	212	454	335	646	476
1"	12	371	273	955	704	1348	995	M22	2.5	344	254	567	418	807	595
1-1/8"	7	480	354	1077	794	1746	1288	M22	1.5	381	281	613	452	873	644
1-1/8"	12	539	397	1208	891	1958	1445	M24	3	444	327	714	526	1017	750
1-1/4"	7	677	500	1519	1120	2463	1817	M24	2	488	360	769	567	1095	808
1-1/4"	12	750	553	1682	1241	2728	2012	M27	3	656	484	1050	774	1496	1103
1-3/8"	6	888	655	1992	1469	3230	2382	M27	2	719	530	1119	825	1594	1176
1-3/8"	12	1011	746	2268	1673	3677	2712	M30	3.5	906	668	1420	1047	2033	1499
1-1/2"	6	1179	869	2643	1949	4286	3161	M30	2	1000	738	1600	1180	2250	1659
1-1/2"	12	1326	978	2974	2194	4823	3557	M36	4	1534	1131	2482	1830	3535	2607

**Notes:**

This chart is an approximate estimate of torque values.

Always tighten hardware to these values unless a different torque value or tightening procedure is listed for a specific application.

Fasteners must always be replaced with the same grade as specified in the manual.

Always use the proper tool for tightening hardware: SAE for SAE hardware and Metric for Metric hardware.



# Mini Round Baler

## SRB-870 Twine Wrap



## Parts Manual

# Frame

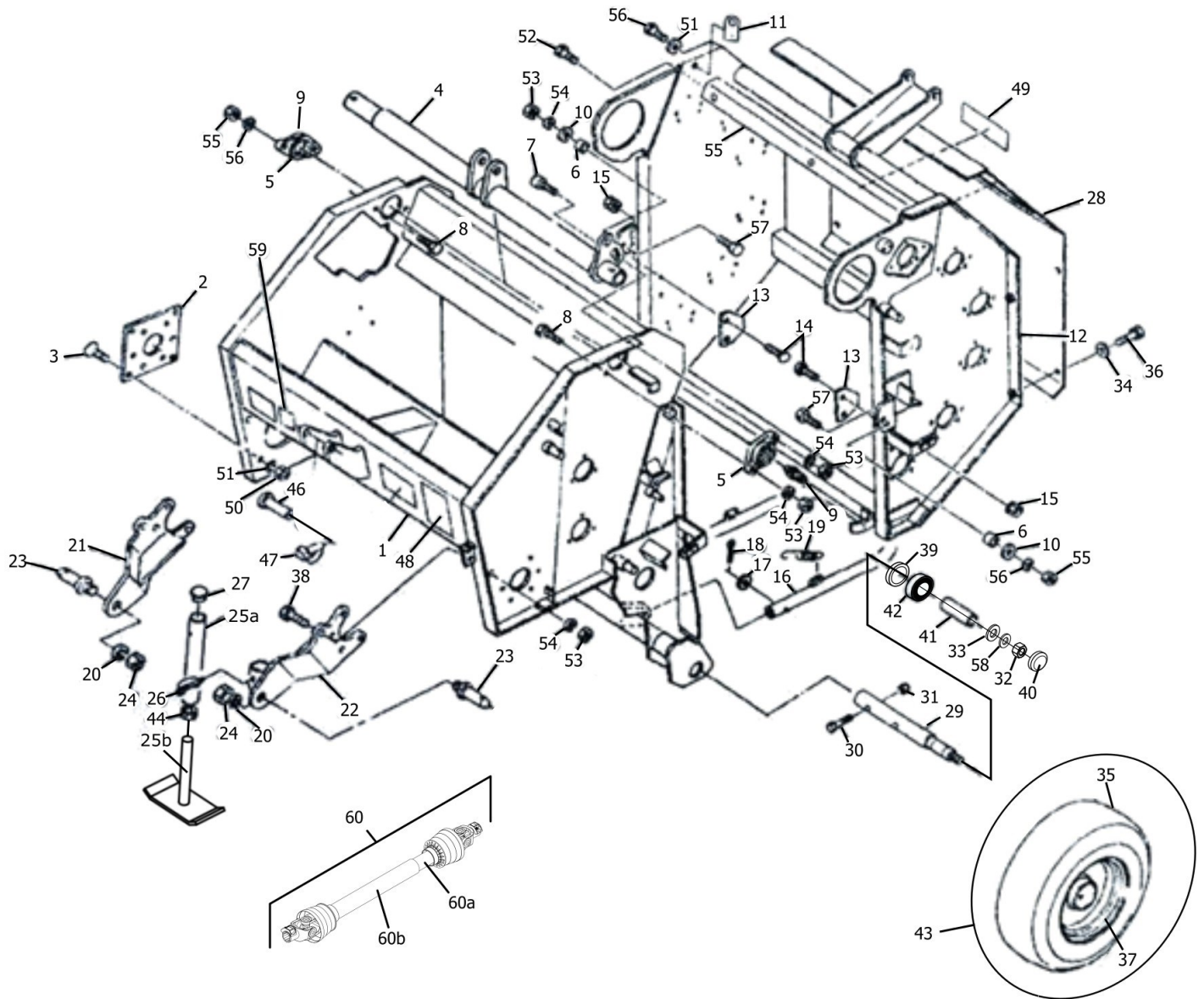

SRBW003 Baler Hatch Controller Cord (see page 11 for details)

SRBW004 Complete Buzzer Cord (see page 11 for details)

## Frame

Item	Part #	Description	Qty.
1	7006780004	Frame	1
2	079506500M	Plate	1
3	BJ10025	Flat head bolt M10x25 (10.9) hexagon socket	4
4	1334380000	Pivot pipe	1
5	0793823004	Housing	2
6	079383100M	Collar	2
7	BH12030	Cap (BOLT) M12x30 (10.9)	1
8	BM1217530	Bolt HH M12-1.75x30 (8.8)	3
9	GN0615	Grease nipple M6-1.50	2
10	FW12	Flat washer M12	2
11	122258000M	Bracket	1
12	7005700004	Gate	1
13	079385000M	Plate	2
14	055032000M	Square neck bolt M8x15	4
15	NM08125	Nut HH M08-1.25	4
16	0793861004	Ejector	1
17	FW10	Washer flat M10	1
18	PC32016	Split pin M3.2x16	1
19	064082000M	Spring (A)	2
20	LW22	Washer lock M22	2
21	1114320004	Arm (right)	1
22	1114351004	Arm (left)	1
23	000006200M	Hitch pin Cat. 1	2
24	NM2215	Nut HH M22-1.50	2
25	1114381004a	Upper tube	1
-	1114381004b	Foot	1
-	1114381004	Stand complete (stand tube, stand foot & M20 nut)	-
26	000453000M	Delta pin #9	1
27	0008510000	Cap #28.6	1
28	1194450003	Rear cover	1
29	087253100M	Shaft	2
30	BM1217570	Bolt HH M12-1.75x70 (8.8)	2
31	LNM12175	Nut lock M12-1.75	2
32	LNM1420	Nut lock M14-2.0	2
33	FW14	Washer flat M14	2
34	FW08	Washer flat M08	9
35	0812241000	Tire 16x6.50-4PR	2
36	BM0812516	Bolt HH M08-1.25x16	9

# Frame

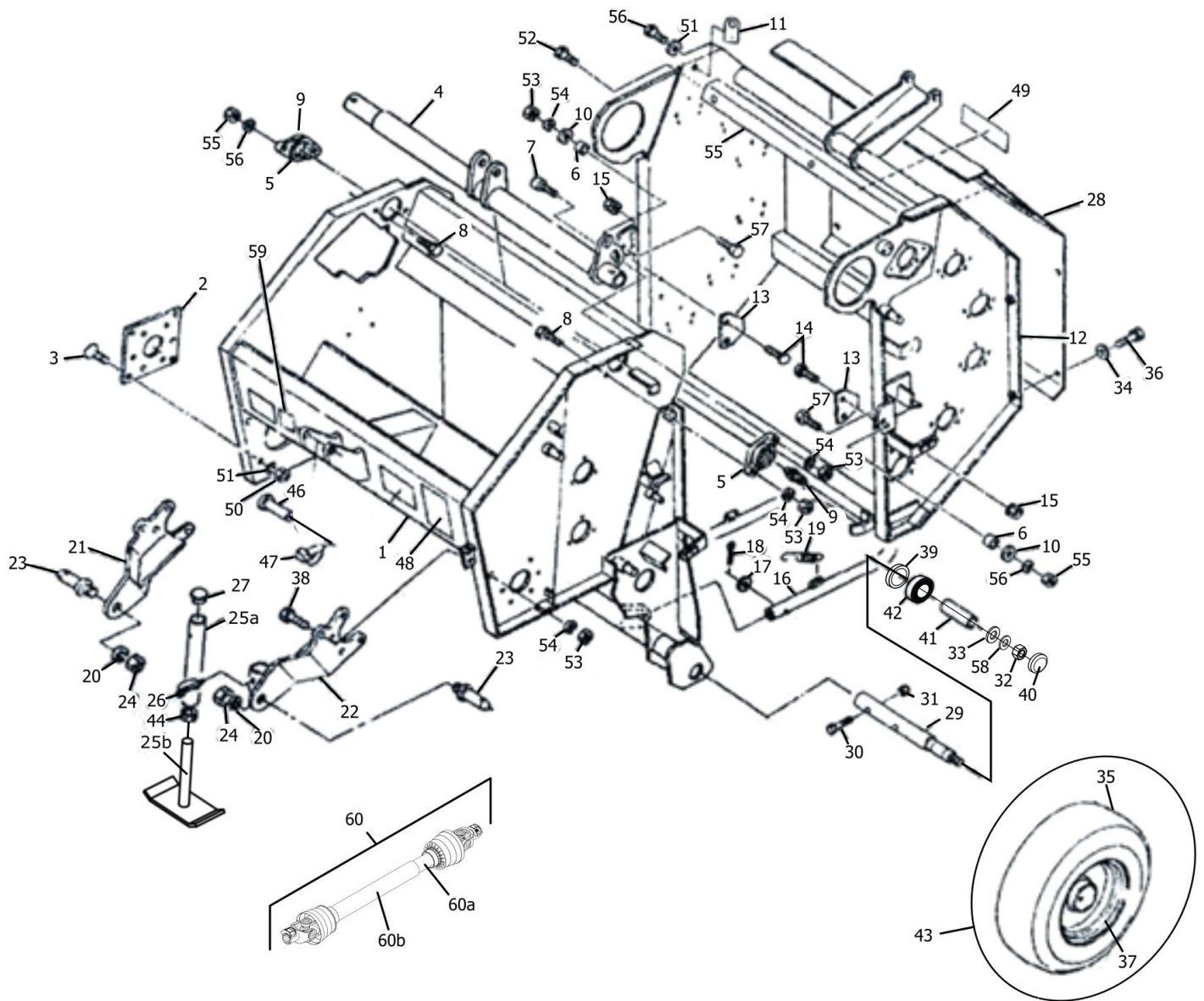

## Frame

Item	Part #	Description	Qty.
37	700513000F	Wheel 5.3751-8	2
38	BM1217555	Bolt HH M12-1.75x55 (8.8)	2
39	000532000M	Oil seal 30 x 52 x 7	2
40	000762000M	Cap	2
41	08122600000	Collar	2
42	B62052RS	Bearing #6205LLU	4
43	0009190000	Tire assembly 16x6.50-8-4PR	2
44	NM20	Nut M20 (4)	2
45			
46	700057000M	Uplink pin	1
47	000739000M	Lynch pin	1
48	70200030000	Decal warning 65	1
49	7020040000	Decal warning 75	1
50	NM1015	Nut M101.50 (8)	4
51	LW10	Washer lock M10	5
52	BM0812525	Bolt HH M08-1.25x25	2
53	NM12175	Nut HH M12-1.75	8
54	LW12	Washer lock M12	8
55	1205870004	Bracket	1
56	BM1017525	Bolt HH M10-1.75x25 (8.8)	1
57	BM1217550	Bolt HH M12-1.75x50 (8.8)	2
58	LW14	Washer lock M14	2
59	7020100000	Decal Rotary speed	1
60	YKPTO870	PTO driveline complete	1
60a	DP1074M-40	Complete Male End (IE) - Series 40 Protection	1
60b	DP1074F-40	Complete Female End (TE) - Series 40 Protection	1

# Gearbox

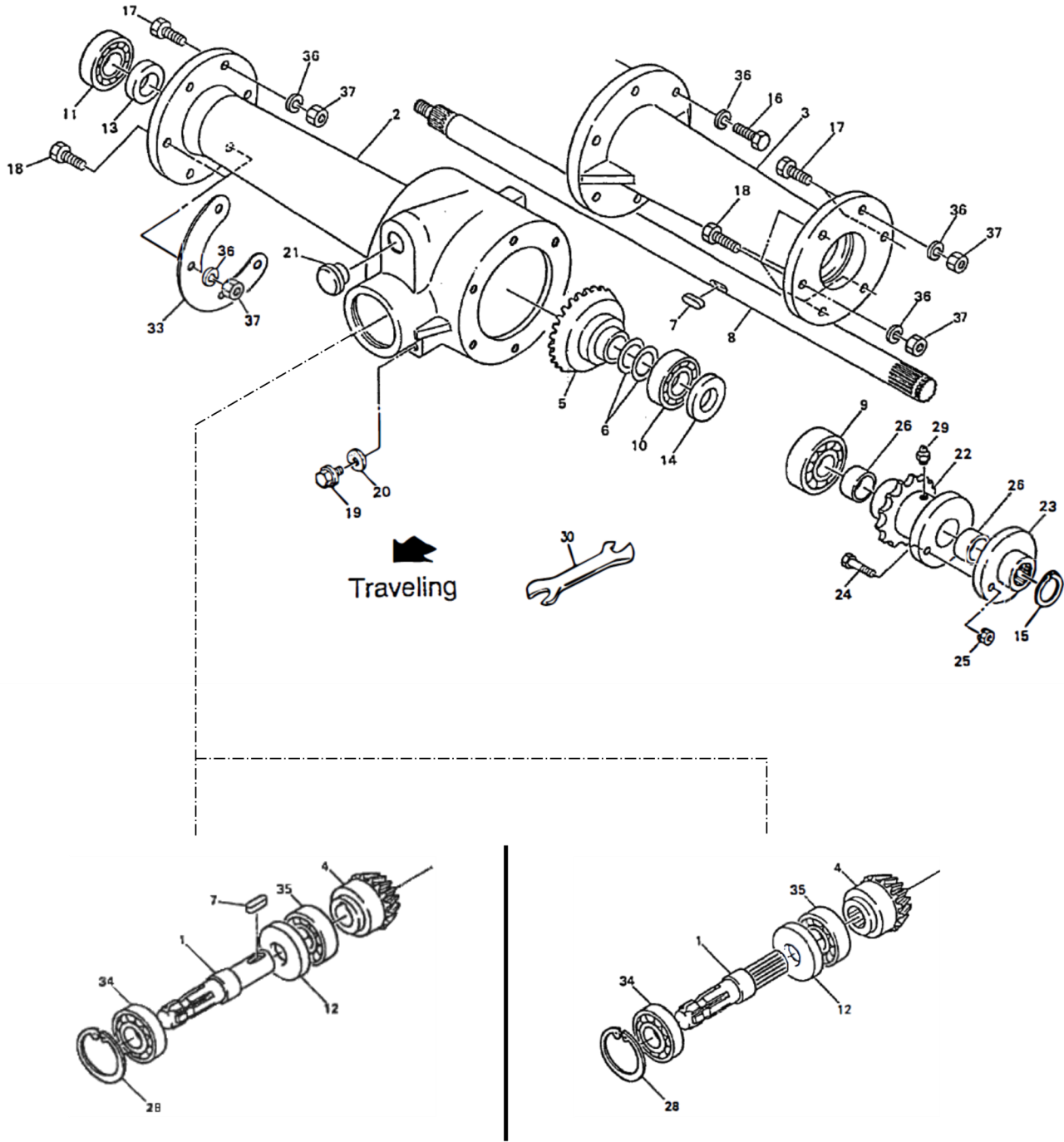

Fig.1

Fig.2

**Note:** Before ordering, determine the correct type of Input Shaft and Bevel Gear.

Fig. 1 Serial #10139 and below: Input Shaft (1) and Bevel Gear (2) uses a Key (4).

Fig. 2, Serial #10140 and above: Input Shaft (1) and Bevel Gear (2) have splines, no key.

See Parts List for part numbers.

## Gearbox

Item	Part #	Description	Qty.
1	7005870000	Shaft (PIC) w/keyway (Serial #10139 and below)	1
	7005870000N	Shaft (PIC) w/splines (Serial #10140 and above)	1
2	1114530004	Gear box	1
3	1114540004	Box frame	1
4	0740981000	Bevel gear 12T w/keyway (Serial #10139 and below)	1
	0740981000N	Bevel gear 12T w/splines (Serial #10140 and above)	1
5	0740971000	Bevel gear 22T	1
6	0556990000	Shim	-
7	KM0707025	Key 7x7x25	2
8	1225130000	Shaft	1
9	B6305	Bearing #6305-2RS	1
10	J6305	Bearing #6305	1
11	B6304RS	Bearing #6304-2RS	1
12	OS406210	Oil seal D40x62x10	1
13	OS254507	Oil seal D25x45x7	1
14	OS255208	Oil seal D25x52x8	1
15	DC025	Snap ring #25	1
16	BM101525	Bolt HH M10-1.50x25	6
17	BM101530	Bolt HH M10-1.50x30	4
18	BM101550	Bolt HH M10-1.50x50	8
19	000338000M	Plug M10	1
20	0003390000	Packing	1
21	0007170000	Oiling cap	1
22	0793232004	Sprocket 16T	1
23	0797931004	Holder, shear bolt	1
24	0812320000	Shear bolt M6x30 (including 10 pieces)	11
25	LN0610	Nut lock M06-1.00	11
26	077471000	Nylon bushing	2
27			
28	SRI-62	Snap ring #62	1
29	GN0615	Grease nipple A-M6-1.50	1
30	111458000M	Plate #4.5	1
31	B6007	Bearing #6007LLU	1
32	B6206	Bearing #6206	1
33	WSA10	Spring washer M10	18
34	NM1015	Nut HH M10-1.50	14
	SRBWB002	Central Gearbox Complete	1

# Rollers

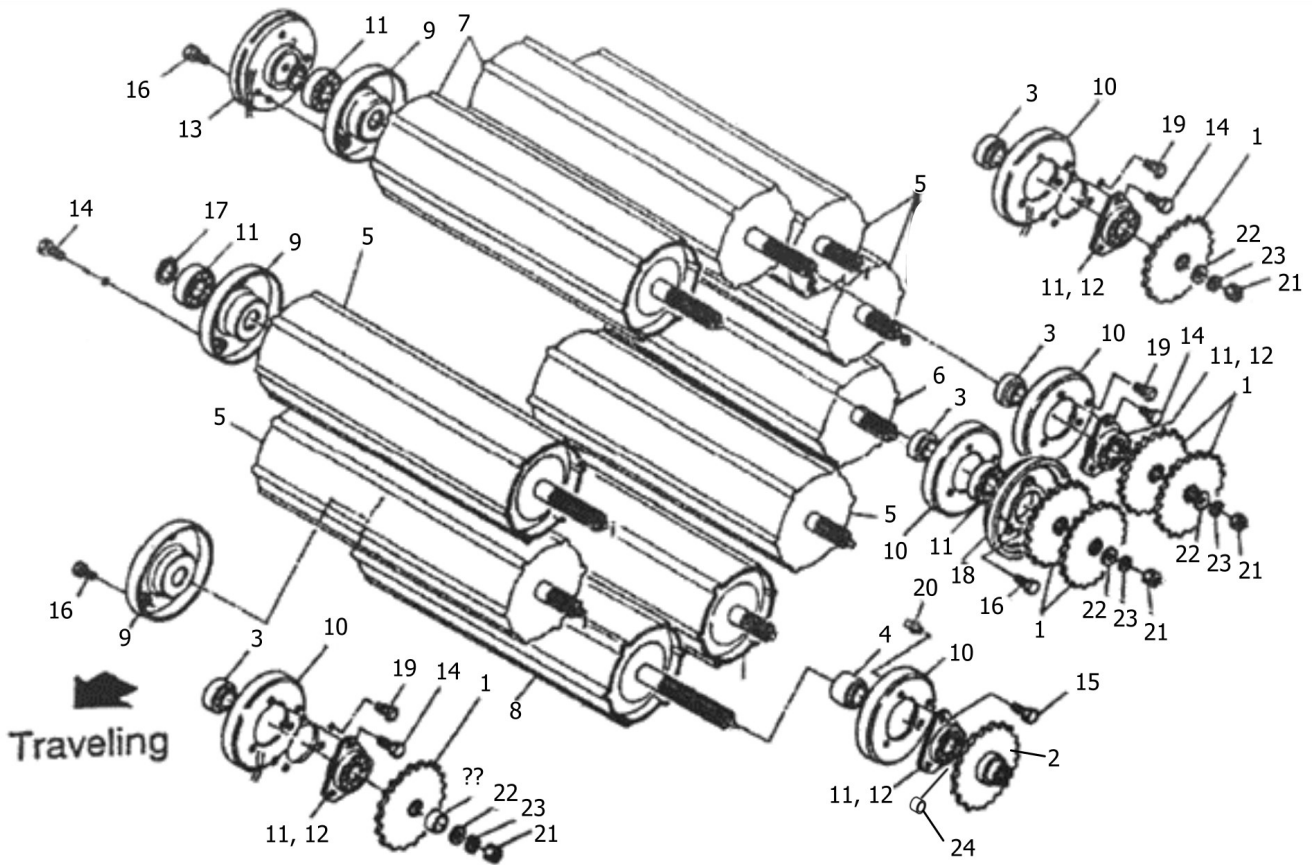

## Rollers

<b>Item</b>	<b>Part #</b>	<b>Description</b>	<b>Qty.</b>
1	079324300M	Sprocket 22T	11
2	079325300M	Sprocket 22T	1
3	079326200M	Collar (A)	9
4	079327300M	Collar (B)	1
5	0851321004	Roller (1)	5
6	0851343004	Roller (2)	1
7	0851351004	Roller (3)	3
8	0851363004	Roller (4)	1
9	079507100M	Flange	10
10	081235000M	Flange	10
11	JCS205LLU	Bearing #CS205LLU	20
12	055149300M	Bi-flange	18
13	0793472004	Housing	1
14	BM0812520	Bolt HH M8-1.25x20	48
15	BM0812525	Bolt HH M8-1.25x25	3
16	BM0812530	Bolt HH M8-1.25x30	9
17	SRE-25	Snap ring #25	10
18	0793461004	Housing	1
19	0815250000	Push rivet 6x6	18
20	0815260000	Push rivet 6x10	2
21	LNM1620	Nut lock M16-2.0	9
22	FW16	Washer flat M16	9
23	LW16	Washer lock M16	9
24	SRBW058	Bushing, flange	3

# Chain Drive

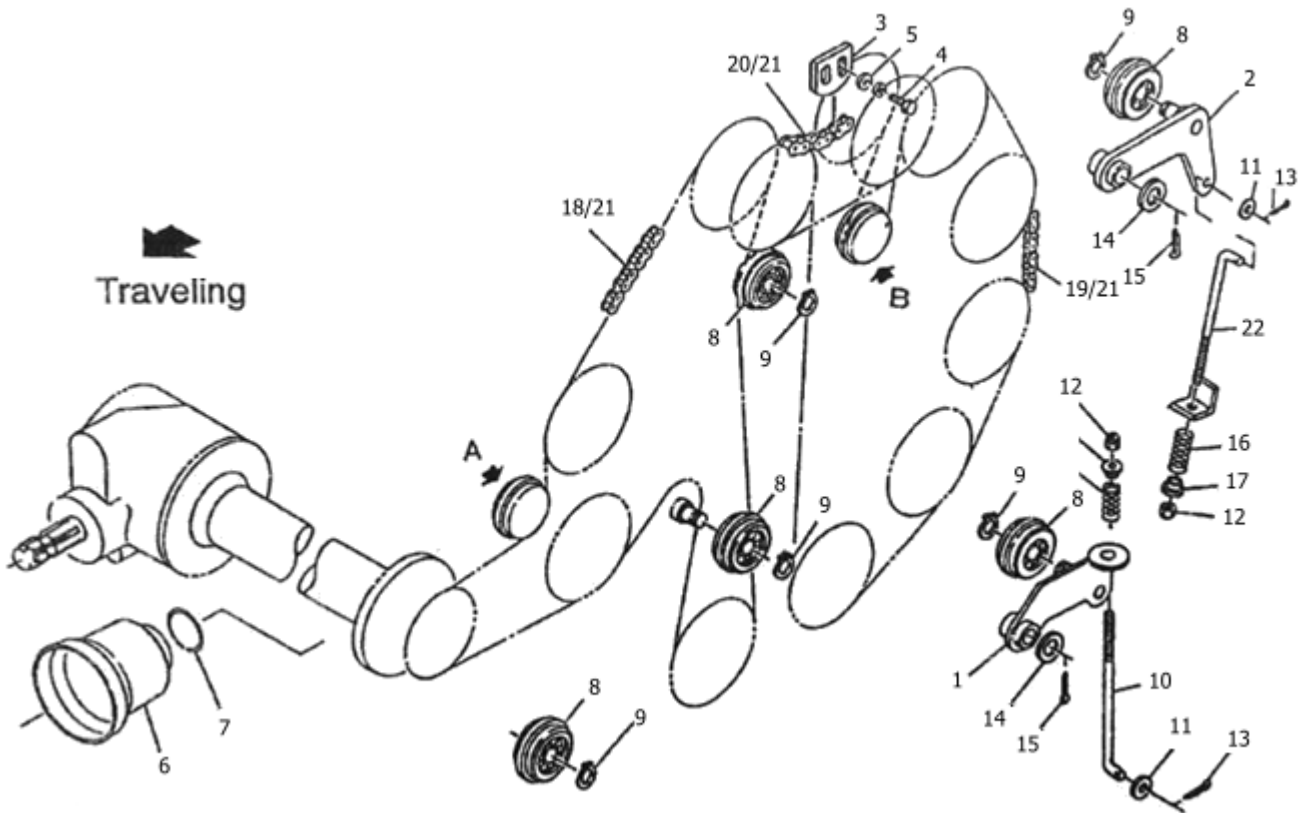

## Chain Drive

Item	Part #	Description	Qty.
1	122514000M	Tension arm (A)	1
2	081741000M	Tension arm (B)	1
3	079331200M	Tension plate	1
4	BM081025	Bolt HH M8-1.00x25	2
5	FW08	Washer flat M08	2
6	00082230000	PIC cover (1)	1
7	00082510000	Ring (S)	1
8	081267000M	Tension roller	4
9	DC017	Snap ring #17	4
10	081742000M	Rod - short	1
11	FW10	Washer flat M10	2
12	LNLM1015	Nut lock M10-1.5	2
13	PC032016	Split pin 3.2x16	2
14	FW20	Washer flat M20	2
15	CP3x35	Split pin 3.2x32	2
16	085350000M	Spring	2
17	085351000M	Collar	2
18	LASH50144	Roller chain 50x168L	1
19	LASH50126	Roller chain 50x146L	1
20	LASH50042	Roller chain 50x42L	1
21	ASH50	Connecting link #50	3
22	081742000M-1	Rod - Long	1

# Pick-up Frame Section 1

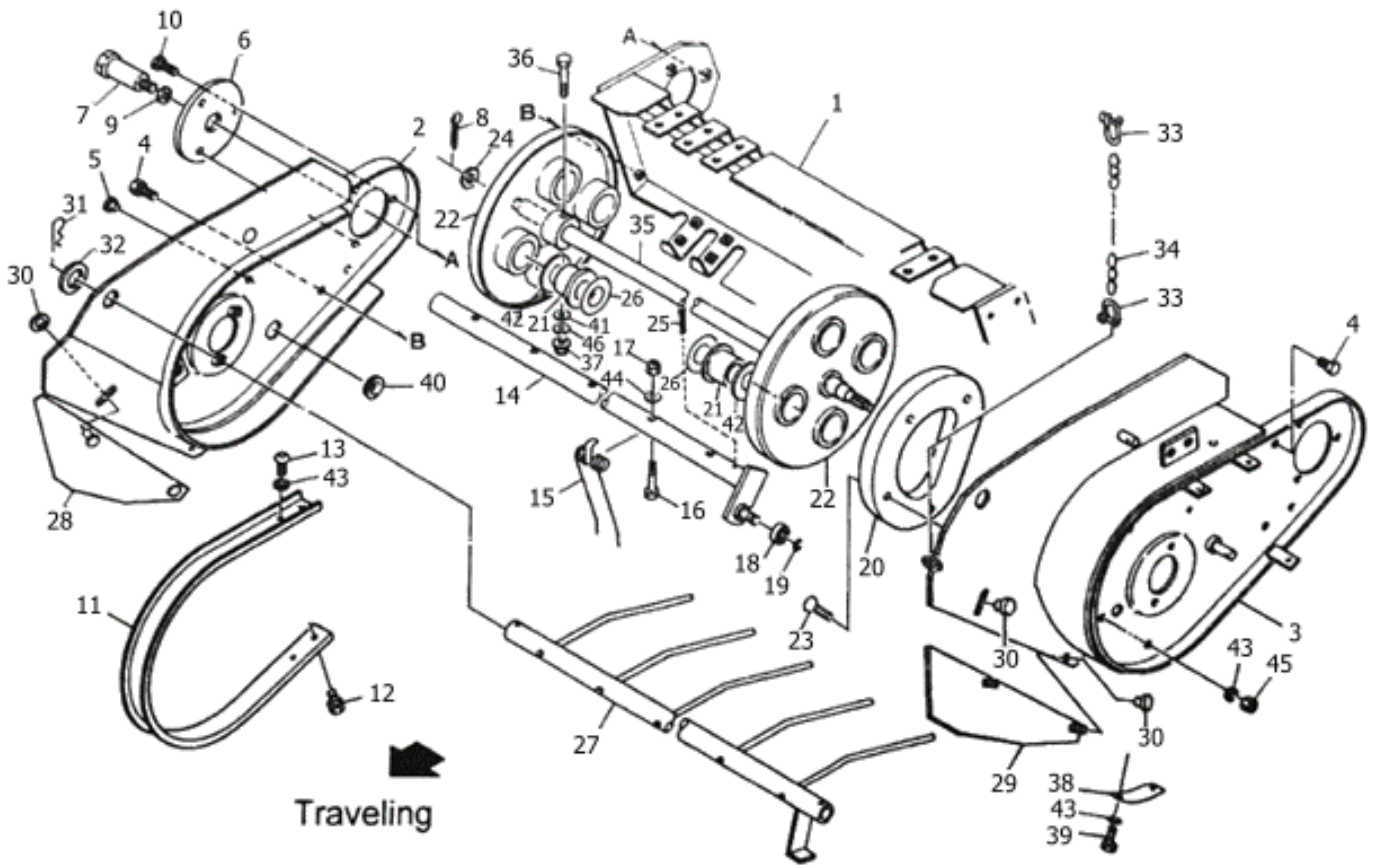

## Pick-up Frame Section 1

Item	Part #	Description	Qty.
1	1335650004	Pick-up frame	1
2	1114492004	Side plate (right)	1
3	1334510004	Side plate (left)	1
4	BM0812520	Bolt HH M8-1.25x20	5
5	7007200000	Cap #9	4
6	079308100M	Plate	1
7	079307300M	Shaft	1
8	PC050036	Split pin 5x36	1
9	LW14	Washer lock M14	1
10	BM0812525	Bolt HH M8-1.25x25	3
11	085222100M	Rotor flush	11
12	BM0812520	Bolt HH M81.25x20	22
13	RBT08020	Bolt M8x20 (10.9)	22
14	0852233004	Tine bar	4
15	0852240006	Tine	24
16	BM0812555	Bolt HH M8-1.25x55	24
17	LN08125	Nut lock M08-1.25	24
18	JSBX0126LLU	Unit bearing #SBx0126LLU	4
19	SRE-12	Snap ring #12	4
20	0792823004	Cam	1
21	0640350000	Nylon bushing	8
22	0862373004	Tine plate	2
23	BJ08020	Flat head bolt M8x12 (10.9)	4
24	057788100M	Shim	1
25	PC050056	Split pin 5x56	8
26	065487000M	Shim 35x1.2	12
27	0852270004	Crop cover	1
28	0822400004	Side cover (right, option)	1
29	0822420004	Side cover (left, option)	1
30	0442890000	Grip M8	4
31	RC3	Snap pin 19x3	2
32	060807100M	Washer	2
33	700260000M	Shackle 6-1/4	2
34	700261000M	Link chain 4x23Px32	1
35	13345200001	Shaft	1
36	BX10070	Bolt M10x70 (10.9)	2
37	LN01015	Nut lock M10-1.50	2
38	094889200M	Plate	1
39	BM0812512	Bolt HH M8-1.25x12 (7)	2
40	0591440000	Grommet	1

# Pick-up Frame Section 1

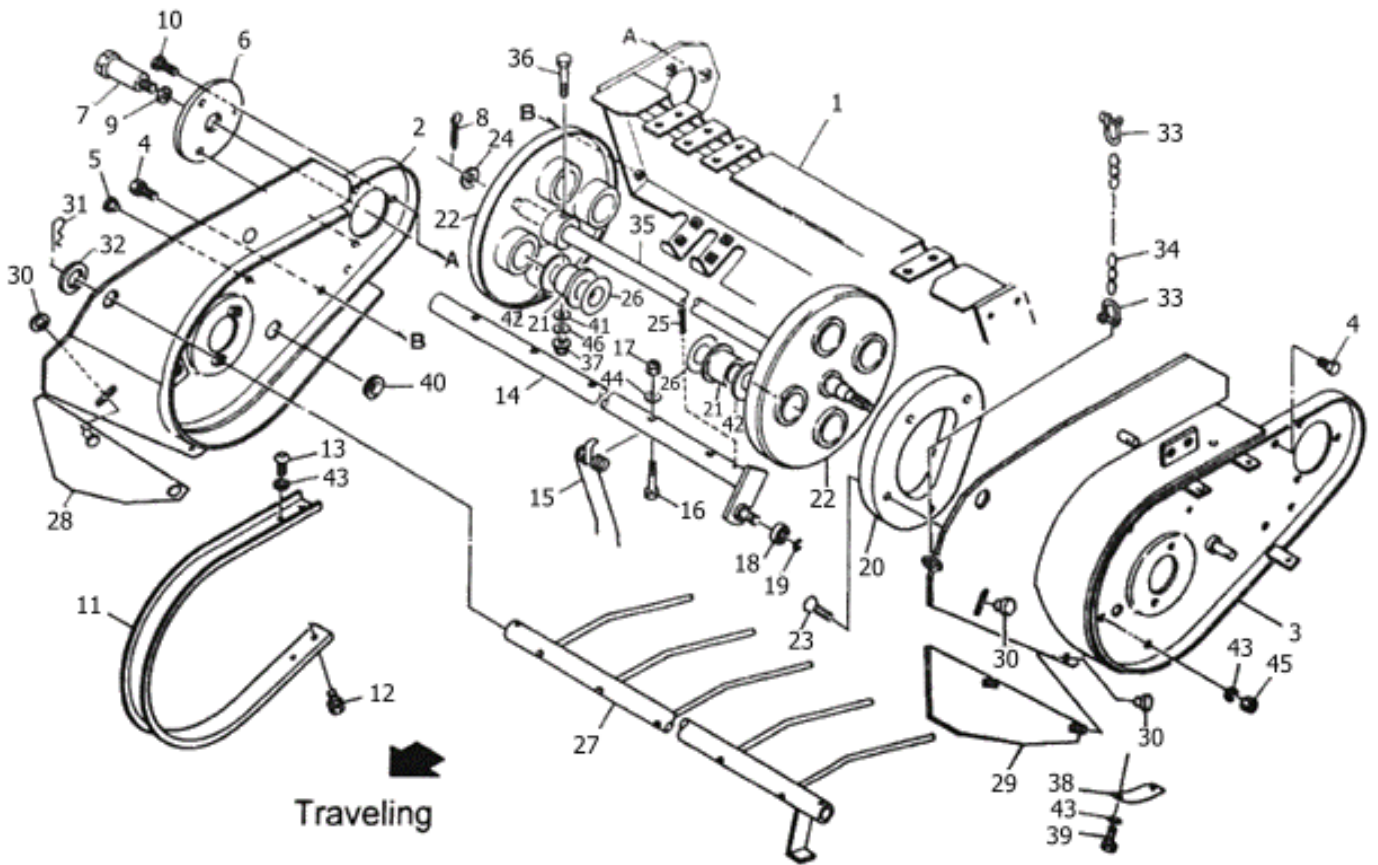

## Pick-up Frame Section 1

<b>Item</b>	<b>Part #</b>	<b>Description</b>	<b>Qty.</b>
41	FW10	Washer flat M10	2
42	1032990000	Washer 43x3.2	8
43	LW08	Washer lock M8	28
44	FW08	Washer flat M8	24
45	NM08125	Nut M8-1.25 (8)	4
46	LW10	Washer lock M10	2

# Pick-up Frame Section 2

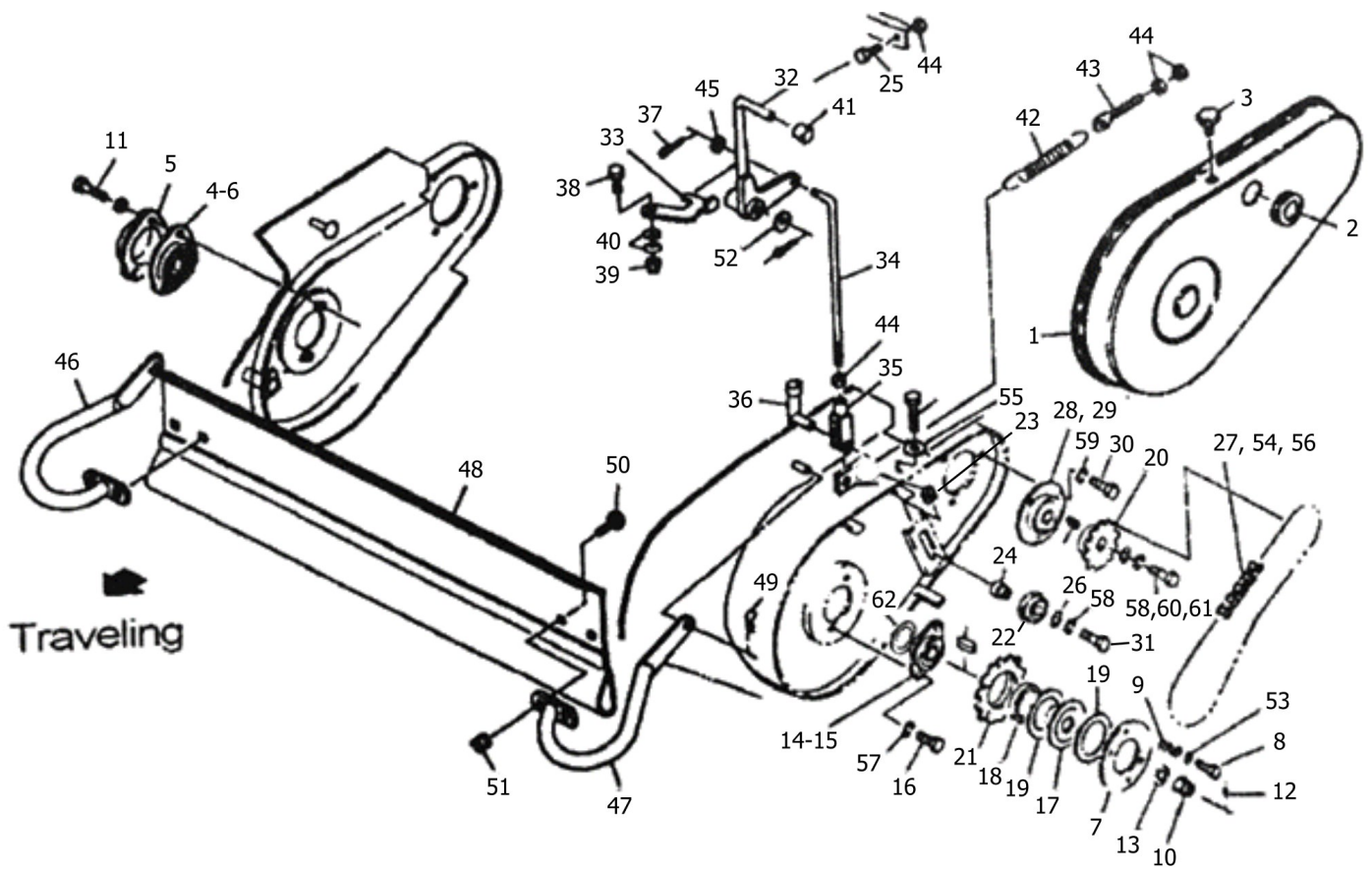

## Pick-up Frame Section 2

Item	Part #	Description	Qty.
1	7006630004	Pick-up cover	1
2	0591440000	Grommet	1
3	0006900000	Grip M8x14	3
4	JCS204LLU	Unit bearing #CS204LLU	1
5	085226100M	Flange	1
6	JPFL204G	Bi-flange PFL204	1
7	133456000M	Lock plate	1
8	BM101565	Bolt HH M10-1.50x65	4
9	043249201M	Spring 8"	4
10	NC2H20150	Notch nut M20x1.5 GB9457	1
11	BM0812525	Bolt HH M8-1.25x25 (8.8)	2
12	PC040025	Split pin 4x25	1
13	FW20	Washer flat M20	1
14	117957000M	Bi-flange PFL205	2
15	JCS205LLU	Bearing CS205-2RS	1
16	BM101520	Bolt HH M10-1.50x20	2
17	133454000M	Boss 17x1.6	1
18	0709092000	Bushing 3.2x32	1
19	0432480010	Facing plate M12 (8)	2
20	133453000M	Sprocket RS50x18T	1
21	133455000M	Sprocket RS50x32T	1
22	081267000M	Tension roller	1
23	080925000M	Nut	1
24	082660000M	Collar	1
25	BM101540	Bolt HH M10-1.50x40 (8.8)	1
26	FW12	Washer flat M12	1
27	LA50059	Chain 10A-59x1	1
28	JPF206G	Bi-flange PF206	2
29	JCS206LLU	Bearing CS206-2RS	1
30	BM101520	Bolt HH M10-1.50x20 (8.8)	3
31	BM1217545	Bolt HH M12-1.75x45 (8.8)	1
32	10541000M	Lever CP	1
33	087493000M	Lock plate	1
34	122518000M	Rod	1
35	079422000M	Fork end 10x40	1
36	079423000M	Pin 10x40	1
37	PC032016	Split pin 3.2x16	1
38	BM101530	Bolt HH M10-1.50x30 (8.8)	1
39	LN10	Nut lock M10	1
40	WCL10	Conical spring washer M10	2

# Pick-up Frame Section 2

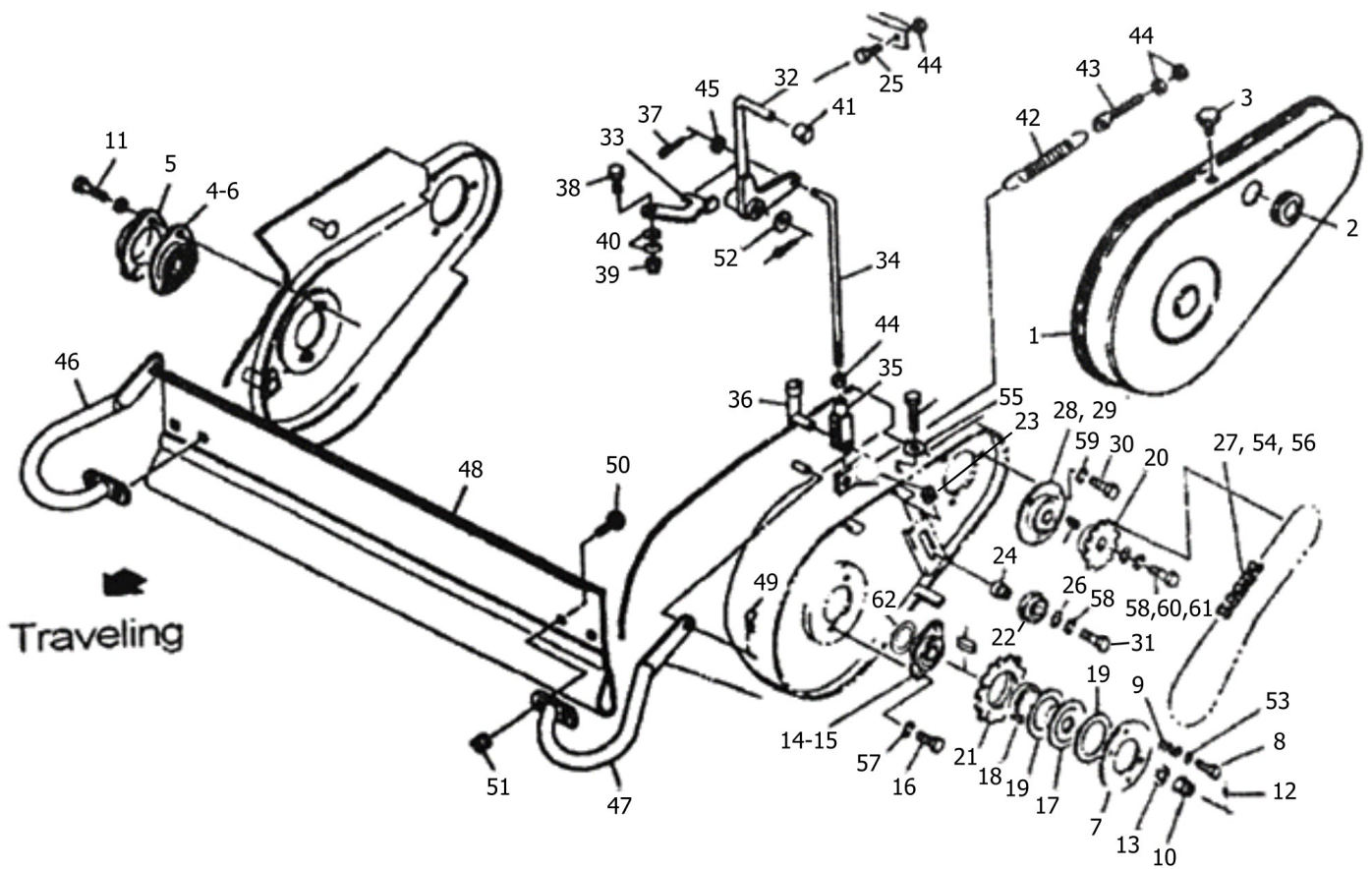

## Pick-up Frame Section 2

Item	Part #	Description	Qty.
41	0007220000	Grip 12	1
42	063275000M	Spring H	2
43	063276000M	Adjustment bolt M10	2
44	NM1015	Nut HH M101.50 (8)	6
45	FW10	Washer flat M10	1
46	0793033004	Stay (right) CP (option)	1
47	0793053004	Stay (left) CP (option)	1
48	0793064004	Cover shield (option)	1
49	000085200M	Snap pin 8x1.6 (option)	2
50	055032000M	Square neck bolt M8x15 (option)	4
51	NSP08	Spring nut (option)	4
52	FW20	Washer flat M20	1
53	FW10	Washer flat M10	4
54	AA050	Connection link 10A	1
56	AD050	Link 10A	1
57	LW10	Washer lock M10	3
58	LW12	Washer M12	2
59	LW10	Washer lock M10	3
60	LNM1420	Nut lock M14-2.00	1
61	FW14	Washer flat M14	1
62	096074000M	Washer 25x35x1.2	1

# Linkage

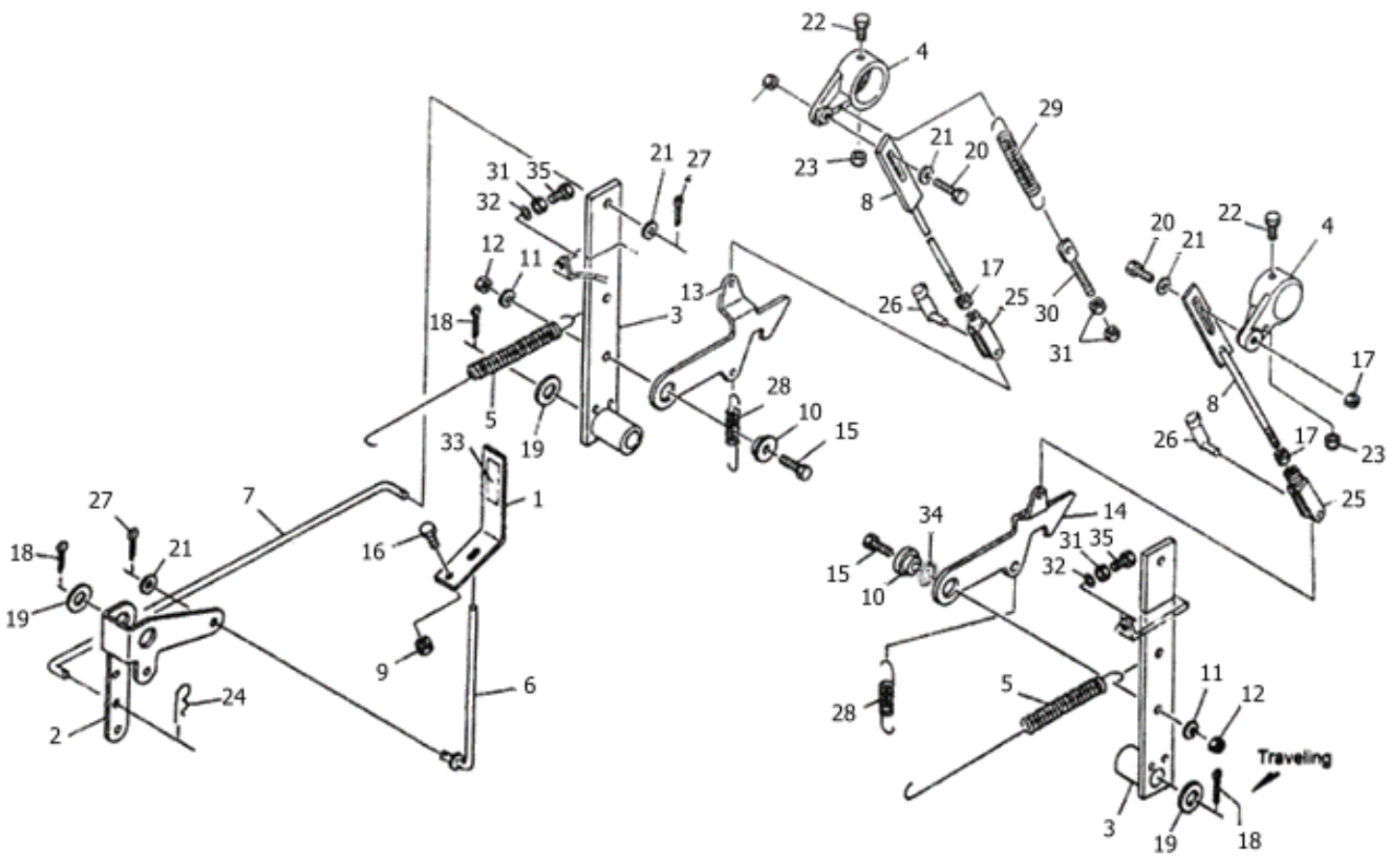

## Linkage

Item	Part #	Description	Qty.
1	1225190004	Plate 1	1
2	122520100M	Bracket	1
3	079364300M	Lever	2
4	0793652004	Bracket	2
5	079366100M	Spring (H)	2
6	079367000M	Rod	1
7	079368100M	Rod	1
8	079359000M	Release rod	2
9	NM08125	Nut HH M08-1.25	1
10	079335100M	Collar	2
11	LW10	Washer lock M10	2
12	LNM10	Nut lock M10	2
13	079373100M	Stopper (right)	1
14	079374100M	Stopper (left)	1
15	BM101535	Bolt HH M10-1.50x35	2
16	BM101520	Bolt HH M10-1.50x20	1
17	NSZ08	Nut M8 (8)	4
18	CP3x35	Split pin 3.2x32	3
19	FW20	Washer M20	3
20	BM0812525	Bolt HH M8-1.25x25	2
21	FW08	Washer flat M08	4
22	BM0812575	Bolt HH M08-1.25x75	2
23	LNM08125	Nut lock M08-1.25	2
24	PC032106	Snap pin 3.2x16	1
25	079424000M	Fork end 8x32	2
26	079425000M	Pin 8x32	2
27	PC032016	Split pin 3.2x16	2
28	074132000M	Spring 2.3x18x68	2
29	079375100M	Spring (H)	1
30	063276000M	Bolt M10 adjustment	1
31	NM1015	Nut HH M10-1.50	4
32	LW10	Washer lock M10	2
33	0792650000	Mark	1
34	1149870000	Shim 10.5x0.27	-
35	BM101535	Bolt HH M10-1.50x35	2

# Sheet Metal

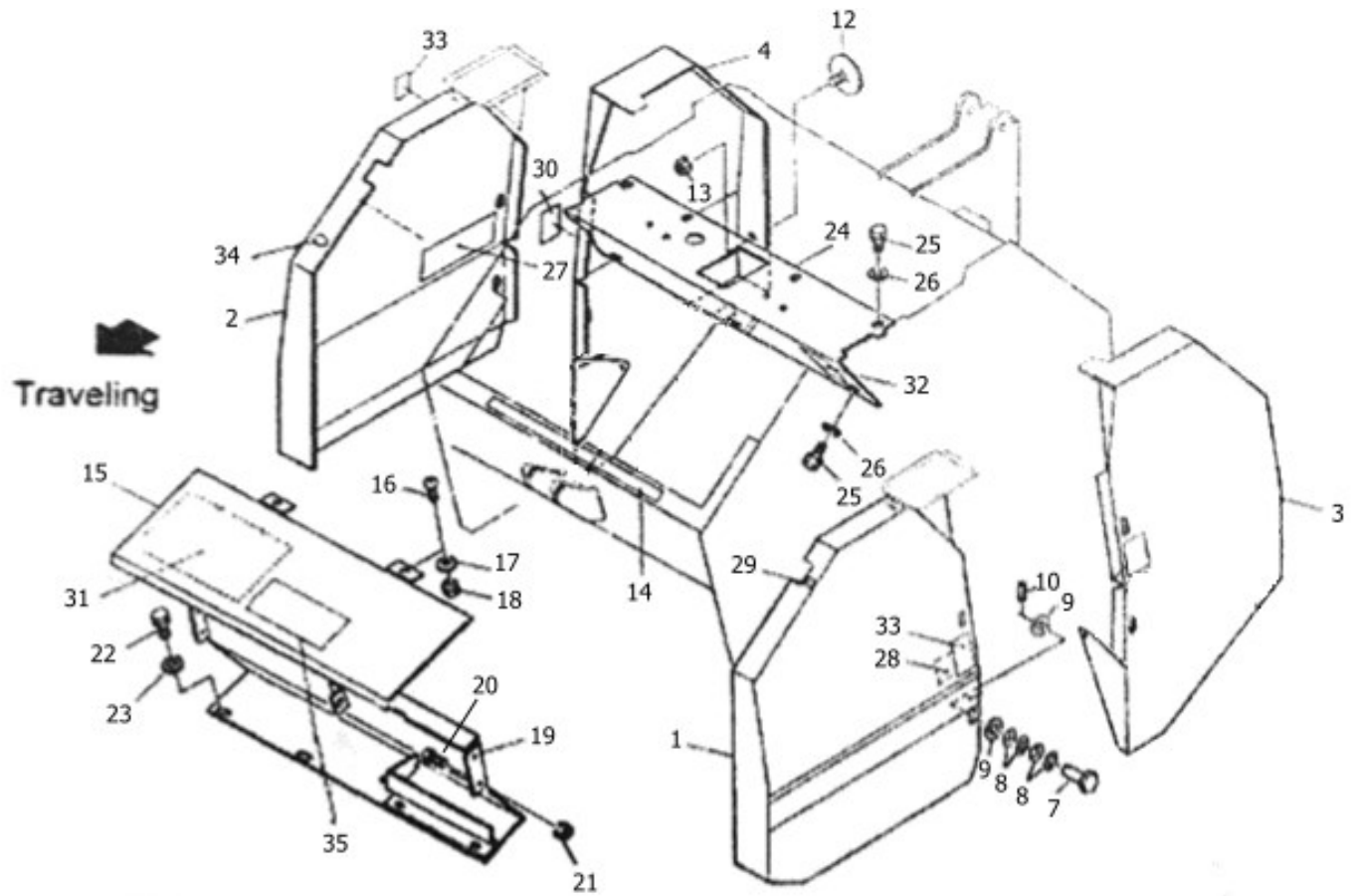

## Sheet Metal

Item	Part #	Description	Qty.
1	1251290003	Cover (left)	1
2	1251300003	Cover (right)	1
3	1229681003	Gate cover (left)	1
4	1229711003	Gate cover (right)	1
5			
6			
7	0796583000	Grip #50	8
8	079659100M	Coned disc spring	32
9	FW08	Washer M08	16
10	PS040016	Spring pin 4x16	8
11			
12	0009311000	Reflector R-80CL (with ref. no. 13)	2
13	NSP05	Spring nut M5	2
14	0793782000	Rubber magnet	1
15	1232600003	Twin cover	1
16	CP06012	Cross-recessed screw	2
17	FW06	Washer flat M6	2
18	LN06	Nut lock M06	2
19	0794495004	Twin cover (rear)	1
20	BM0812520	Bolt HH M08-1.25x20	4
21	LN08	Nut lock M08	4
22	BM0812520	Bolt HH M081.25x20	4
23	FW08	Washer flat M08	4
24	1225521003	Top cover	1
25	BM0812520	Bolt HH M081.25x20	8
26	FW08	Washer flat M08	8
27	7020090000	Label; 11	1
28	7020080000	Label; 10	1
29	7020060000	Label; 8	1
30	7020000000	Label; 3	2
31	7019970000	Mark	1
32	7019990000	Label; 2	1
33	7019980000	Label; 1	2
34	7019920000	Mark	1
35	7020010000	Label; 4	1

# Hydraulic Section

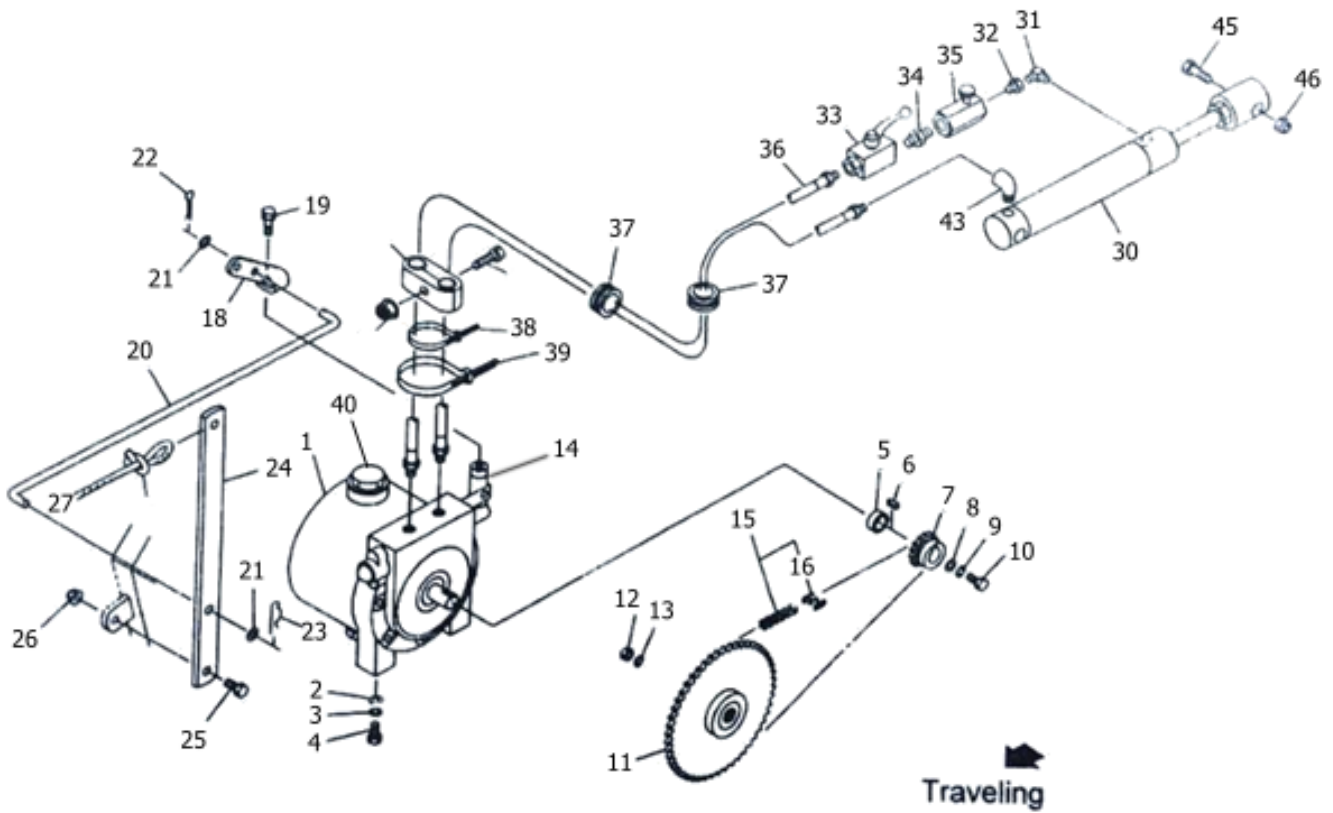

## Hydraulic Section

Item	Part #	Description	Qty.
1	1226130000	Power package 95R	1
2	075290100M	Washer #10	2
3	LW10	Washer M10	2
4	BM1012525	Bolt HH M10-1.25x25	2
5	122614100M	Collar 14x6	1
6	KFD05050200	Key 5x5x20	1
7	122615000M	Sprocket 40x9T	1
8	FW06	Washer flat M06	1
9	LW06	Washer lock M06	1
10	BM061016	Bolt HH M06x16	1
11	1248668000M	Sprocket 40x43T	1
12	LNM1420	Nut lock M14-2.00	1
13	FW14	Washer flat M14	1
14	SRBW005	Power package solenoid	1
15	LA40056	Roller chain	1
16	AA040	Connecting link #40	1
17			
18	122617100M	Lever	1
19	BM08125616	Bolt HH M08-1.25x16	1
20	122618000M	Rod	1
21	FW08	Washer flat M08	2
22	PC032016	Split pin 3.2x16	1
23	000085200M	Snap pin 8x1.6	1
24	122619000M	Lever	1
25	BM0812525	Bolt HH M08-1.25x25	1
26	LNM08125	Nut HH M08-1.25	1
27	0858621000	Rope	1
28			
29			
30	122370006	Cylinder CSH35x210x375	1
31	700268000M	Hose elbow G1/4xR1/4	1
32	700167000M	Hose swivel (male) G1/4xR1/4	1
33	0009280000	Stop valve #1/4	1
34	700269000M	Nipple PT1/4	1
35	1125310000	Valve #1/4	1
36	7001660000	Oil pressure hose 1/4x1000 S1-S902	2
37	7000520000	Grommet Ø35	2
38	ILT100	Band 2.5x100	3
39	ILT250	Band 4.8x251	1
40	1226130000C	Cap - power package	1

# Hydraulic Section

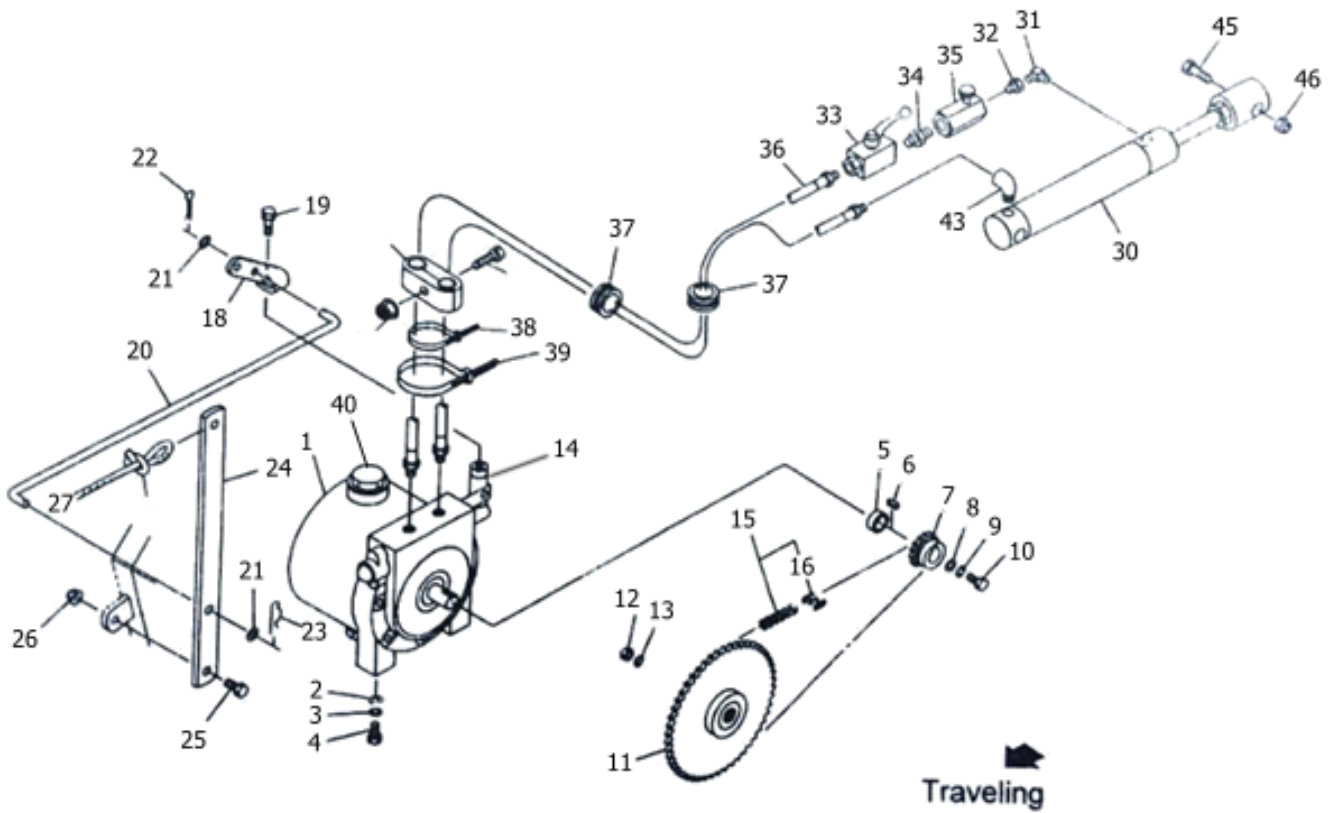

## Hydraulic Section

Item	Part #	Description	Qty.
41			
42			
43	700167000M	Hose swivel (male) G14xR1/4	4
44	700265000M	Elbow G1/4	2
45	BM162080	Bolt HH M16-2.00x80 (4.6)	2
46	LN16	Nut lock M16-2.00	2

# Binding Base Section1

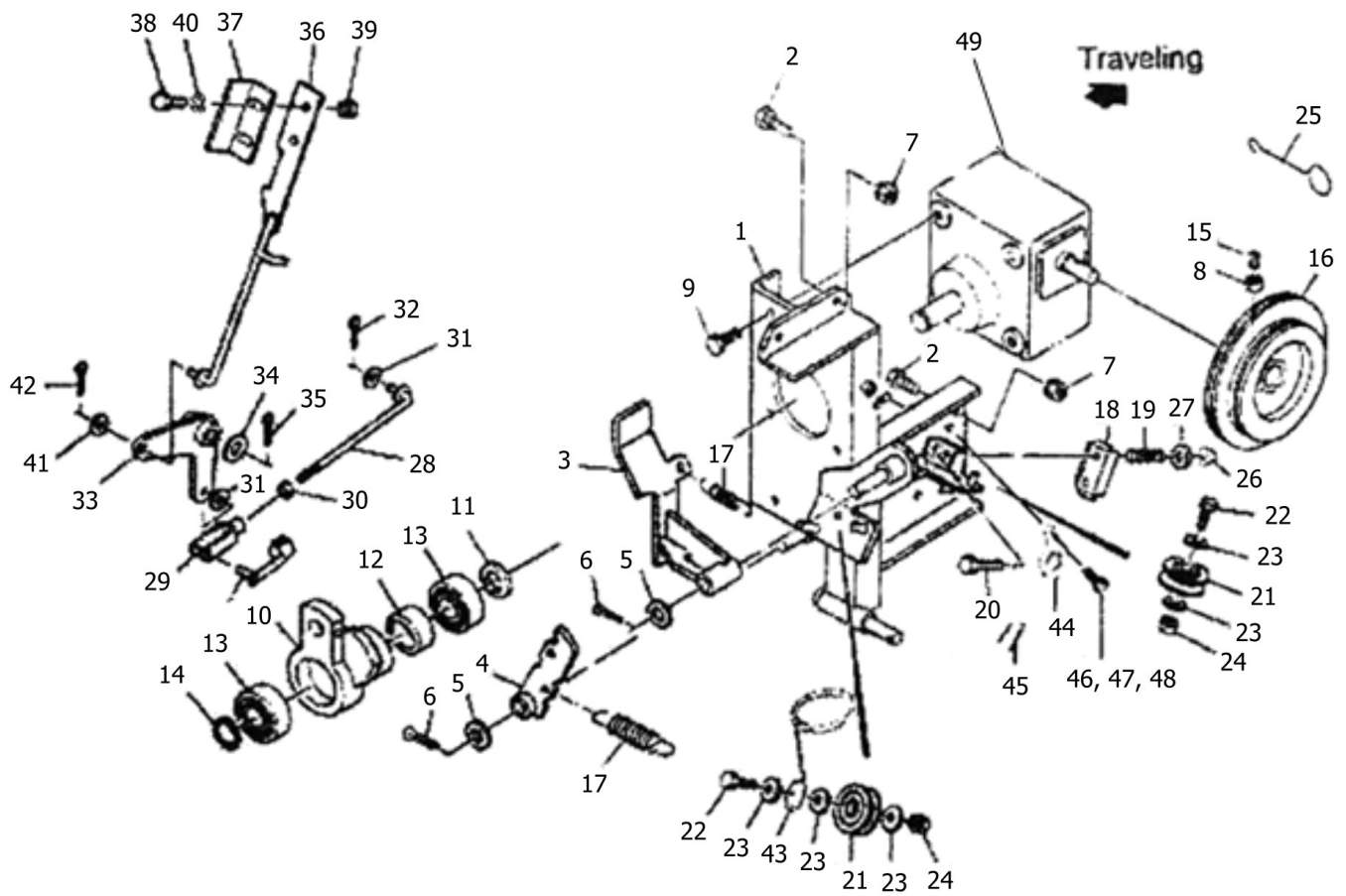

## Binding Base Section1

Item	Part #	Description	Qty.
1	0812277004	Binding base (1)	1
2	BM0812520	Bolt HH M08-1.25x20	6
3	079471200M	Latch	1
4	079472100M	Clutch bar	1
5	FW12	Washer flat M12	2
6	PC032016	Split pin 3.2s16	2
7	LN08125	Nut lock M08	6
8	NM08125	Nut HH M08-1.25	1
9	BM0812520	Bolt HH M08-1.25x20	4
10	0809760004	Arm	1
11	081222000M	Collar	1
12	JHF2520	One-way clutch HF2520	1
13	J6005LLU	Bearing #60005LLU	2
14	SRE-25	Snap Ring #25	1
15	TRK08020	Set screw M8x20 (10.9)	1
16	1019510000	Twine pulley	1
17	077412000M	Spring (H)	1
18	079495000M	Tension plate	1
19	013290101M	Spring	2
20	BM061050	Bolt HH M06-1.00x50	2
21	079496100M	Guide roll	2
22	BM0812530	Bolt HH M08-1.25x30	2
23	LW08	Washer lock M08	4
24	LN08125	Nut lock M08-1.25	2
25	079469100M	Twine threader	1
26	LN0610	Nut lock M06-1.00	2
27	FW06	Washer flat M06	2
28	105411000M	Rod	1
29	079424000M	Fork end 8x32	1
30	NM08125	Nut HH M08	1
31	FW08	Washer flat M08	2
32	PC032016	Split pin 3.2x16	1
33	079371300M	Link	1
34	FW12	Washer flat M12	1
35	PC032016	Split pin 3.2x16	1
36	079372100M	Control bar	1
37	079500100M	Angle	1
38	BM061020	Bolt HH M06x20	2
39	LN0610	Washer lock M06-1.00	2
40	FW06	Washer flat M06	2

# Binding Base Section1

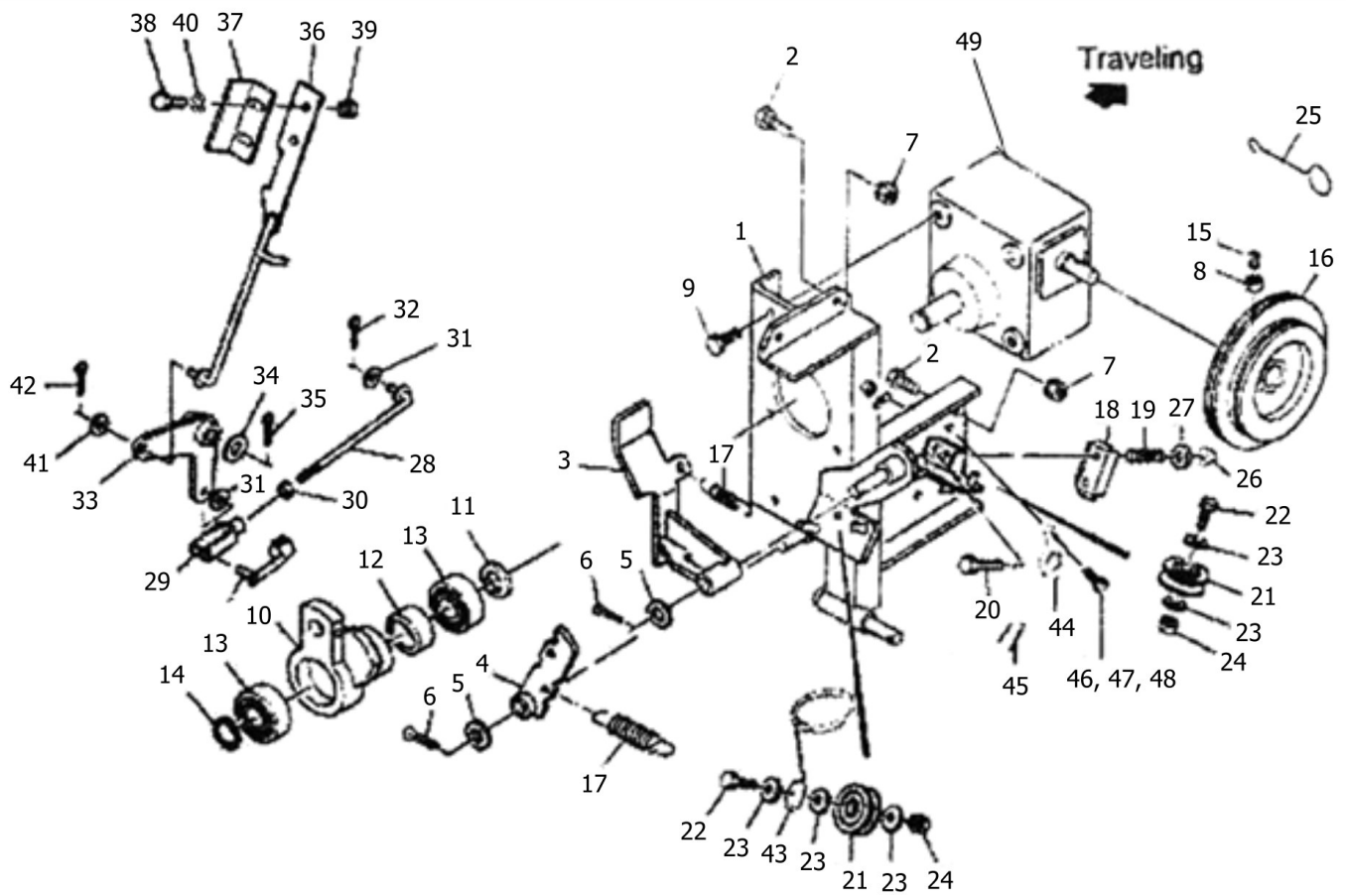

## Binding Base Section1

Item	Part #	Description	Qty.
41	FW08	Washer flat M08	1
42	PC032016	Split pin 3.2x16	1
43	126418000M	Twine guide	1
44	7001470000	Buzzer	1
45	7001490000	Power line	1
46	BM061020	Bolt HH M06x20	1
47	LN0610	Nut lock M06-1.00	1
48	LW06	Washer lock M06	1
49	SRBWB001	Worm drive gearbox	1

# Binding Base Section2

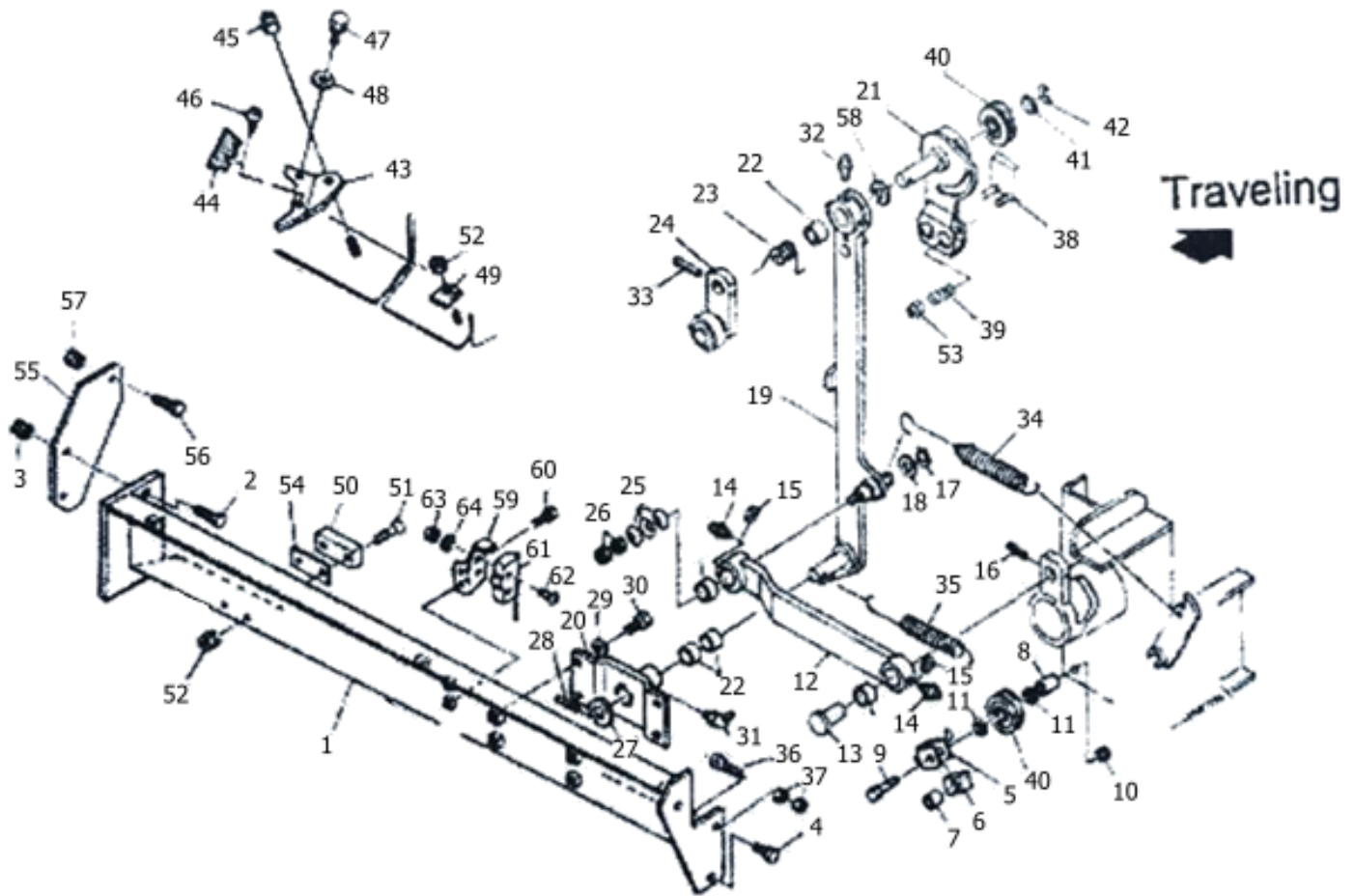

## Binding Base Section2

Item	Part #	Description	Qty.
1	1200800004	Binding base (2)	1
2	BM0812520	Bolt HH M08-1.25x20	2
3	LN08125	Nut lock M08-1.25	2
4	BM0812520	Bolt HH M08-1.25x20	2
5	079473300M	Cushion base	1
6	0794741000	Cushion rubber	1
7	0194751000	Collar	1
8	079466200M	Collar	1
9	BM0812580	Bolt HH M08-1.25x80	1
10	LN08125	Nut lock M08-1.25	1
11	FW08	Washer flat M08	2
12	079483400M	Crank bar	1
13	079484400M	Pin	1
14	GN0615	Grease nipple A-M6	2
15	FW06	Washer flat M06	2
16	PS060036	Spring pin 6x36	1
17	SRE-15	Snap ring #15	1
18	FW16	Washer flat M16	1
19	120085000M	Arm (1)	1
20	080102700M	Arm support	1
21	120090000M	Arm (2)	1
22	0774093000	Bush	5
23	120094000M	Spring	1
24	120095000M	Arm (3)	1
25	079659100M	Coned disc spring	3
26	LN08125	Nut lock M08-1.25	2
27	061847000M	Spanner nut	1
28	PS050032	Star washer	1
29	FW08	Washer flat M08	4
30	BM0812520	Bolt HH M08-1.25x20	4
31	GN0615	Grease nipple B-M6	1
32	GN0615	Grease nipple A-M6	1
33	PS060036	Spring pin 6x36	1
34	080893000M	Spring (H)	1
35	0794892006	Spring (H)	1
36	080103100M	Bolt M8	1
37	NM08125	Nut HH M08-1.25	1
38	120098000M	Tension plate	2
39	077377100M	Spring (A)	1
40	079496100M	Guide roll	1

# Binding Base Section2

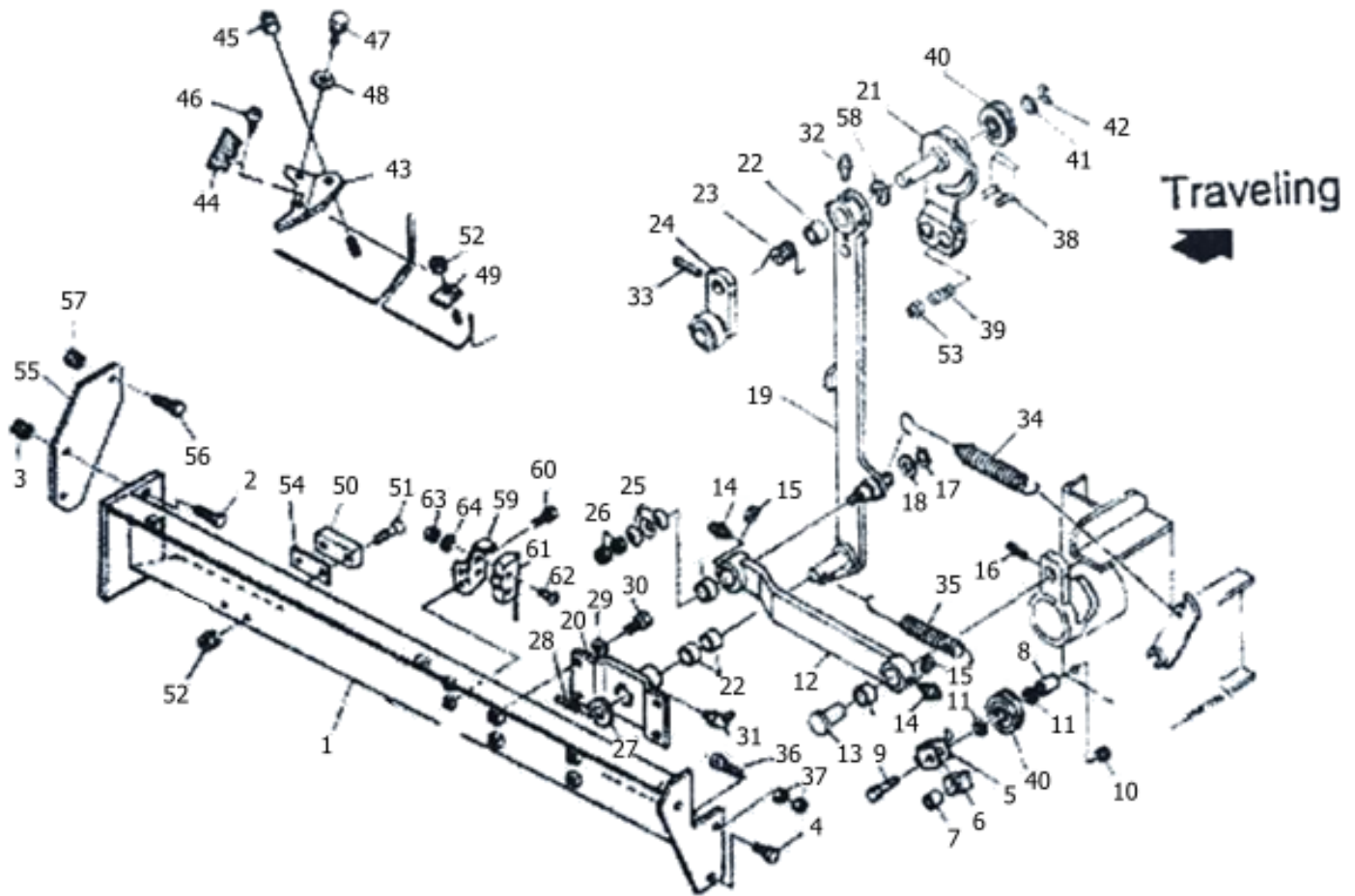

## Binding Base Section2

Item	Part #	Description	Qty.
41	FW08	Washer flat M08	2
42	LNM08125	Nut HH M08-1.25	1
43	079497100M	Knife plate	1
44	1020460000	Knife	1
45	NNF08	Flange nylon nut M8	1
46	TPA03006	Tapping screw A 3x6	1
47	BM0812520	Bolt HH M08-1.25x20	1
48	FW08	Washer HH M08	1
49	0794981000	Cushion rubber	1
50	1200990000	Resin rubber	1
51	BJ08035	Flat head bolt M8x35 (10.9)	2
52	LNM08125	Nut lock M08-1.25	3
53	LNM0610	Nut lock M06-1.00	1
54	122289000M	Shim	1
55	1225480004	Spacer	1
56	BM0812516	Bolt HH M08-1.25x16	1
57	LNM08125	Nut lock M08-1.25	1
58	FW16	Washer flat M16	1
61	080104300M	Angle	1
62	BM0812520	Bolt HH M08-1.25x20	1
63	0801051000	Switch	1
64	CP04030	Cross-recessed screw M4x30	2
65	NP04	Spring nut M4	2
66	WRA04	Washer M4	2
-	7001480000	Cable	1
-	7001470000	Cable	1
-	7000230000	Buzzer	1
-	BM061020	Bolt HH M06-1.00x20	2
-	FW06	Washer flat M06	2
-	LNM0610	Nut HH M06-1.00	2
-	0801070000	Cable clamp	1
-	7001490000	Power cable	1

# Warranty

## LIMITED WARRANTY

Belco Resources Equipment warrants to the original purchaser of any new piece of machinery from Belco Resources Equipment, purchased from an authorized Belco Resources Equipment dealer, that the equipment be free from defects in material and workmanship for a period of one (1) year for non-commercial, state, and municipalities' use, ninety (90) days for commercial use from date of retail sale. Warranty for rental purposes is thirty (30) days. The obligation of Belco Resources Equipment to the purchaser under this warranty is limited to the repair or replacement of defective parts.

Replacement or repair parts installed in the equipment covered by this limited warranty are warranted for ninety (90) days from the date of purchase of such part or to the expiration of the applicable new equipment warranty period, whichever occurs later. Warranted parts shall be provided at no cost to the user at an authorized Belco Resources Equipment dealer during regular working hours. Belco Resources Equipment reserves the right to inspect any equipment or parts, which are claimed to have been defective in material or workmanship.

This limited warranty does not apply to and excludes wear items such as shear pins, tires, tubes knives, blades or other wear items. Oil or grease is not covered by this warranty.

All obligations of Belco Resources Equipment under this limited warranty shall be terminated if:

- Proper service is not performed on the machine.

- The machine is modified or altered in any way.

- The machine is being used or has been used for purposes other than those for which the machine was intended.

## DISCLAIMER OF IMPLIED WARRANTIES & CONSEQUENTIAL DAMAGES

Belco Resources Equipment obligation under this limited warranty, to the extent allowed by law, is in lieu of all warranties, implied or expressed, including implied warranties of merchantability and fitness for a particular purpose and any liability for incidental and consequential damages with respect to the sale or use of the items warranted. Such incidental and consequential damages shall include but not be limited to: transportation charges other than normal freight charges; cost of installation other than cost approved by Belco Resources Equipment; duty; taxes; charges for normal service or adjustment; loss of crops or any other loss of income; rental of substitute equipment, expenses due to loss, damage, detention or delay in the delivery.

## REGISTRATION

The online Warranty Registration must be completed in order to qualify for coverage on this Limited Warranty. Visit [br-equipment.com](http://br-equipment.com), click on "Warranty Registration" and completely fill out the form to register the new piece of equipment.

**Page left blank intentionally**

**Page left blank intentionally**

**Page left blank intentionally**



401 Jeffreys Road  
Rocky Mount, NC 27804  
[www.tarrivermfg.com](http://www.tarrivermfg.com)

Tel: 252-822-7140  
Fax: 252-787-5855  
[Sales@tarrivermfg.com](mailto:Sales@tarrivermfg.com)