



No Till Drill

SAYA-505 & 507



Operator's Manual

SAYA-505, Serial #41243 & above

SAYA-507, Serial #62119 & above

Page left blank intentionally

TO THE DEALER:

Assembly and proper installation of this product is the responsibility of the Tar River dealer. Read manual instructions and safety rules. Make sure all items on the Dealer's Pre-Delivery and Delivery Check Lists in the Owner's/Operator's Manual are completed before releasing equipment to the owner.

TO THE OWNER:

Read this manual before operating your Tar River equipment. The information presented will prepare you to do a better and safer job. Keep this manual handy for ready reference. Require all operators to read this manual carefully and become acquainted with all the adjustment and operating procedures before attempting to operate. Replacement manuals can be obtained from your selling dealer. The equipment you have purchased has been carefully engineered and manufactured to provide dependable and satisfactory use. Like all mechanical products, it will require cleaning and upkeep. Lubricate the machine as specified. Observe all safety information in this manual and safety decals on the equipment. For service, your authorized Tar River dealer has trained mechanics, genuine Tar River service parts, and the necessary tools and equipment to handle all your needs. Use only genuine Tar River service parts. Substitute parts will void the warranty and may not meet standards required for safe and satisfactory operation.

Record your machine model and serial number in the space provide below. Your dealer will need this information to give you prompt, efficient service.

Model Number: _____

Serial Number: _____

Date Purchased: _____

TO THE DEALER: Part 1 of 2

Assembly and proper installation of this product is the responsibility of the Belco Resources Dealer. Read manual instructions and safety rules. Make sure all items on the Dealer's Pre-Delivery List and Owners Check List in the Owner's/Operator's Manual are completed before releasing equipment to the owner.



NOTE: The machine must be inspected thoroughly by the dealer prior to delivery of machine to owner. Place a check mark in the box beside each item checked. Contact Belco Resources Equipment of any damages, issues or shortages to the machine.

Pre-Delivery Checklist - Dealer

- Gearbox oil level
- Check all fluids, hydraulic, gear oil, etc.
- Grease fittings properly lubricated
- Guards, shields, attachments securely fastened
- All hardware tightened
- Condition and tension of V-belts (if applicable)
- Blades properly installed, blade hardware tightened to proper torque specifications
- PTO attached to the machine (if applicable)
- All decals are clean, legible and in proper location
- Operator's Manual on machine

Model #: _____ Serial #: _____

Inspected by (Initials): _____ Date: _____



TO THE DEALER: Part 2 of 2

Dealer is to review the following items to the owner. Place a check mark in the box beside each item reviewed.

Checklist - Owner

- Correct attachment of machine to tractor
- Safe operation of the machine
- Importance of regular lubrication, maintenance and inspection
- Troubleshooting
- Replacing broken or worn parts (importance of using only OEM parts)
- Servicing the machine
- Storage
- Warranty
- Encourage owner to read and understand the Operator’s Manual before operating the machine
- Encourage owner to fill out the “Warranty Registration”, online warranty@br-equipment.com

Purchase Date: _____ **Delivery Date:** _____

Model #: _____ **Serial #:** _____

Dealer Signature _____ **Date:** _____

Customer Signature _____ **Date:** _____

TO THE OWNER:

Read this manual before operating your Belco Resources equipment. The information presented will prepare you to do a better and safer job. Keep this manual handy for ready reference. Require all operators to read this manual carefully and become acquainted with all the adjustment and operating procedures before attempting to operate. Replacement manuals can be obtained from your selling dealer. The equipment you have purchased has been carefully engineered and manufactured to provide dependable and satisfactory use. Like all mechanical products, it will require cleaning and upkeep. Lubricate the machine as specified. Observe all safety information in this manual and safety decals on the equipment. For service, your authorized Belco Resources dealer has trained mechanics, genuine Belco Resources service parts, and the necessary tools and equipment to handle all your needs. Use only genuine Belco Resources service parts. Substitute parts will void the warranty and may not meet standards required for safe and satisfactory operation.

Table of Contents

Introduction	7
Technical Specifications	7
Safety	8
Safety Signal Words	8
General Safety Guidelines	9
Safety Decal Care	9
Before Operation	10
During Operation	11
Highway And Transport Operations	12-13
Assembly	14-16
Operating Instructions.....	17-20
Adjusting Disc Alignment.....	21
Optional Cast Iron Roller Instructions.....	22-25
Lubrication and Maintenance	26-27
Setting Application Rates.....	28
Application Rates	29
Torque Specifications	30
Parts Breakdown	31-55
Warranty	56

Introduction

Thank you for purchasing your SAYA No-Till Drill. The SAYA is designed to be used in **LIGHT DUTY** no-till or prepared seeding conditions. It is important to properly maintain and keep in place all safety guards and shields that came with you machine.

These seeders can seed corn, beans, oats, wheat, etc. The two boxes are equipped with closeable slides for each row. The seeder is equipped with 2 separate boxes. Each is made with a stainless steel box and nylon/plastic seed rollers to disperse seeds effectively and accurately.

Technical Specifications

- Suitable for drilling and fertilizing corn, beans, oats, etc. in level or gently rolling fields.
- Spring load coulters to increase seed/ground contact.
- The double disc coulters create an opening to fertilize and seed easily in tilled soil.
- The depth of seeding can be adjusted. Seeding quantity can be adjusted.
- The seeder can plant seeds, fertilize roll and drag all at the same time.

Model	SAYA-505	SAYA-507
Weight	1036 lbs.	1400 lbs.
Req. HP	Minimum 30 HP	Minimum 35 HP
Seeding Rows	7	10
Row Spacing	7 1/2"	7 1/2"
Seed/Fertilizer Rate	See Seed Rate Chart page 20	See Seed Rate Chart page 20
Sowing Depth	3/4" - 2"	3/4" - 2"
Working width	55"	75"
Cat. hitch	1 & 2	1 & 2
Double disc openers	7 sets	10 sets
Front cup/rear cups	7	10
Hopper Capacity - front	4.00	5.50
Hopper Capacity - rear	3.00	4.50

Important Safety Information

Safety

It is important that you read the entire manual and to become familiar with this product before you begin using it. This product is designed for certain applications only. The manufacturer cannot be responsible for issues arising from modification. We strongly recommend this product not be modified and /or used for any application other than that for which it is designed. If you have any questions relative to a particular application, DO NOT use the product until you have first contacted us to determine if it can or should be performed on the product.

Read and understand this manual and all safety signs before operating and maintaining . Review the safety instructions and precautions annually.

Safety Signal Words

TAKE NOTE! This safety alert symbol found though out this manual is used to call you attention to instructions involving you personal safety and the safety of others. Failure to follow these instructions can result in injury or death.



**This symbol means:
Attention!
Become alert!
Your safety is involved!**

Note the use of the signal words, DANGER, WARNING and CAUTION with the safety messages. The appropriate signal word for each has been selected using the following guidelines:



DANGER: Indicates an imminently hazardous situation that, if not avoided, will result in death or serious injury. This signal word is to be limited to the most extreme situations typically for machine components which, for functional purposes, cannot be guarded.



WARNING: Indicates a potentially hazardous situation that, if not avoided, could result in death or serious injury, and includes hazards that are exposed when guards are removed. It may also be used to alert against unsafe practices.



CAUTION: Indicates a potentially hazardous situation that, if not avoided, may result in minor or moderate injury. It may also be used to alert against unsafe practices.

Important Safety Information

General Safety Guidelines

Safety of the operator is one of the main concerns in designing and developing a new piece of equipment. Designers and manufacturers build in as many safety features as possible. However, every year many accidents occur which could have been avoided by a few seconds of thought and a more careful approach to handling equipment. You, the operator, can avoid many accidents by observing the following precautions in this section. To avoid personal injury, study the following precautions and insist those working with you, or for you, follow them.

Replace any DANGER, WARNING, CAUTION or instruction safety decal that is not readable or is missing. Location of such decals are indicated in this manual. Do not attempt to operate this equipment under the influence of drugs or alcohol.

Review the safety instructions with all users annually.

This equipment is dangerous to children and persons unfamiliar with its operation. The operator should be a responsible adult familiar with farm machinery and trained in this equipment's operations. **Do not allow persons to operate or assemble this machine until they have read this manual and have developed a thorough understanding of the safety precautions and of how it works.**

To prevent injury of death, use a tractor equipped with a Roll Over Protection System (ROPS). Do not paint over, remove or deface any signs or warning decals on your equipment. Observe all safety signs and practice the instructions on them.

Never exceed the limits of a piece of machinery. If its ability to do a job, or to do so safely, is in question - **Don't try it!**



Safety Decal Care

- Keep safety signs clean and legible at all times.
- Replace safety signs that are missing or have become illegible.
- Replaced parts that displayed a safety sign should also display the current safety sign
- Safety signs are available from your Distributor or Dealer Parts Department or the factory.

Important Safety Information

How to install Safety Signs:

- Be sure that the installation area is clean and dry.
- Decide on the exact position before you remove the backing paper.
- Remove the smallest portion of the split backing paper.
- Align the decal over the specified area and carefully press the small portion with the exposed sticky backing in place.
- Slowly peel back the remaining paper and carefully smooth the remaining portion of the decal in place.
- Small air pockets can be pierced with a pin and smoothed out using the piece of decal backing paper.



Before Operation

- Carefully study and understand this manual.
- Do not wear loose-fitting clothing, which may catch in moving parts.
- Always wear protective clothing and substantial shoes.
- Assure that all tires are inflated evenly.
- Give the machine a visual inspection for any loose bolts, worn parts or cracked welds, and make necessary repairs. Follow the maintenance safety instructions included with this manual.
- Be sure that there are no tools lying on or in the equipment.
- Do not use the machine until you are sure that the area is clear, especially of children and animals.
- Don't hurry the learning process or take the machine for granted. Ease into it and become familiar with your new equipment.
- Practice operation of your equipment and its attachments. Completely familiarize yourself and other operators with its operation before using.
- Use a tractor equipped with a Roll Over Protection System (ROPS) and fasten your seat belt prior to starting engine.
- The manufacturer does not recommend usage of tractor with ROPS removed.
- Move tractor wheels to the widest recommended settings to increase stability.
- Securely attach to towing unit. Use a high strength, appropriately sized hitch pin with a mechanical retainer and attach safety chain.
- Do not allow anyone to stand between the tongue or hitch and the towing vehicle when backing up to the equipment.
- Do not use the machine until you are sure that the area is clear, especially of children and animals.

Important Safety Information



During Operation

- Children should not be allowed on the product.
- Clear the area of small children and bystanders before moving the machine.
- If using a towing unit, securely attach machine by using a hardened 3/4" pin, a metal retainer, and safety chains if required. Shift towing unit to a lower gear before going down steep downgrades, thus using the engine as a retarding force. Keep towing vehicle in gear at all times. Slow down for corners and rough terrain.
- Make sure you are in compliance with all local and state regulations regarding transporting equipment on public roads and highways. Lights and slow moving signs must be clean and visible by overtaking or oncoming traffic when machine is transported.
- Beware of bystanders, **particularly children!** Always look around to make sure that it is safe to start the engine of the towing vehicle or move the machine. This is particularly important with higher noise levels and quiet cabs, as you may not hear people shouting.
- **NO PASSENGERS ALLOWED!** Do not carry passengers anywhere on, or in, the tractor or equipment, except as required for operation.
- Keep hands and clothing clear of moving parts.
- Do not clean, lubricate or adjust your equipment while it is moving.
- When halting operation, even periodically, set the tractor or towing vehicle brakes, disengage the PTO, shut off the engine and **remove the ignition key.**
- Be especially observant of the operating area and terrain. Watch for holes, rocks or hidden hazards. Always inspect the area prior to operation.
- **DO NOT** operate near the edge of drop-offs or banks.
- **DO NOT** operate on steep slopes as overturns may result.
- Operate up and down (not across) intermediate slopes. Avoid sudden starts and stops.



WARNING: Never backup with the machine on the ground! This will cause damage to the machine. Always lift the machine high enough to clear the ground before backing up.

Important Safety Information



Highway and Transport Operations

- Adopt safe driving practices.
- Keep the brake pedals latched together at all times. **Never use independent braking with machine in tow as loss of control and/or upset of machine can result.**
- Always drive at a safe speed relative to local conditions and ensure that your speed is low enough for an emergency stop to be safe and secure. Keep speed at a minimum.
- Reduce speed prior to turns to avoid the risk of overturning.
- Avoid sudden uphill turns on steep slopes.
- Always keep the tractor or towing vehicle in gear to provide engine braking when going downhill. Do not coast.
- Do not drink and drive!
- Comply with state and local laws governing highway safety and movement of farm machinery on public roads.
- Use approved accessory lighting flags and necessary warning devices to protect operators of other vehicles on the highway during daylight and nighttime transport. Various safety lights and devices are available from your dealer.
- The use of flashing amber lights is acceptable in most localities. However, some localities prohibit their use. Local laws should be checked for all highway and marking requirements.
- When driving the tractor and equipment on the road or highway under 40 kph (20 mph) at night or during the day, use the amber warning lights and a slow moving vehicle (SMV) identification emblem.
- Plan your route to avoid heavy traffic.
- Be a safe and courteous driver. Always yield to oncoming traffic in all situations, including narrow bridges, intersections, etc.
- Be observant of bridge loading ratings. Do not cross bridges rated at lower than the gross weight at which you are operating.
- Watch for obstructions overhead and to the side while transporting.
- Always operate in a position to provide maximum visibility at all times. Make allowances for increased length and weight of the equipment when making turns, stopping the machine, etc.
- Pick the most level route when transporting across fields. Avoid the edges of ditches or gullies and steep hillsides.
- Be extra careful when working in inclines.

Important Safety Information



Highway and Transport Operations

- Maneuver the tractor or towing vehicle at safe speeds.
- Avoid overhead wires or other obstacles. Contact with overhead lines could cause serious injury or death.
- Avoid loose fill, rocks and holes, they can be dangerous for equipment operation or movement.
- Allow for machine length when making turns,
- Operate the towing vehicle from the operator's seat only.
- Never stand alongside of machine with engine running or attempt to start engine and/or operate machine while standing alongside of machine.
- Never leave running equipment attachments unattended.
- As a precaution, always recheck the hardware on equipment following every 100 hours of operation. Correct all problems. Follow the maintenance safety procedures.

Assembly

Step 1:

Carefully uncrate and remove all parts. Ensure the double disc openers and coulters are inline and set at their proper 7 1/2" spacing.

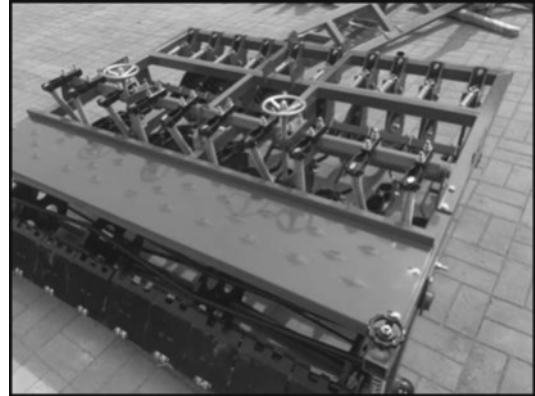

Step 2:

Mount hopper box with the lid opening facing the front of the machine. **DO NOT TIGHTEN THE BOLTS AT THIS TIME!**

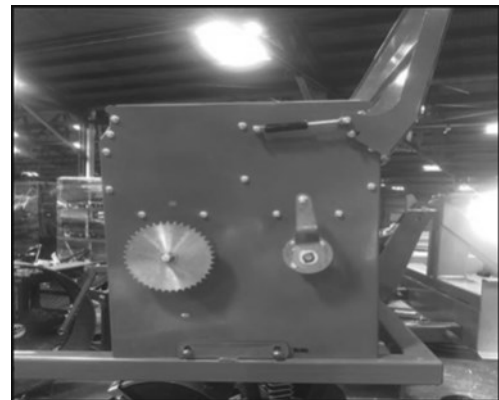

Step 3:

Install the short sprocket shaft, sprocket and chain. The 11 tooth sprocket goes on the left and 12 tooth sprocket on the right.



Step 4:

Lightly push the seed box forward to tighten the chain. Use an allen wrench to tighten the drive sprocket after ensuring the chain is straight. Tighten bolts left loose in Step 2. Install chain shields.

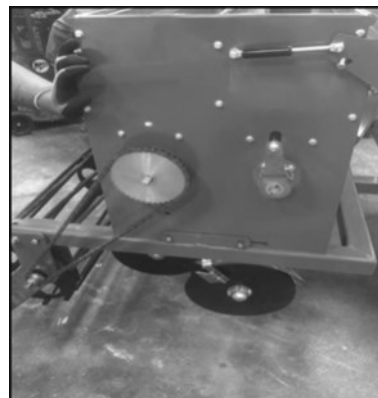

Assembly

Step 5:

Install seed cup funnels and hoses to seed cups.

Slide the wire clamp onto the Fertilizer/seed tube close to the first rib as shown, Fig. A.

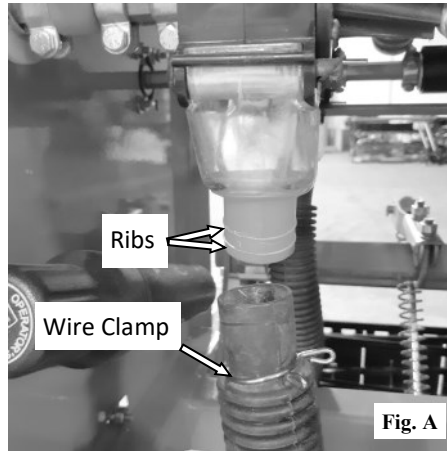

Slide the Fertilizer/seed tube past the ribs on the seed cup funnel until the seed tube end contacts the bottom of the seed cup funnel. Squeeze the wire clamp and slide it up to approximately 1/4"-1/2" from the end of Fertilizer/seed tube, Fig. B.

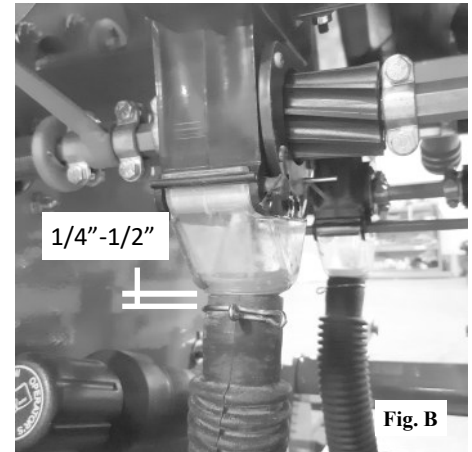

Insert the smaller end of the Fertilizer/seed tube into the seed drill casting retainer clip. To prevent the Fertilizer/seed tube from pulling out, make sure that three ribs are inside the retainer clip, Fig. C.

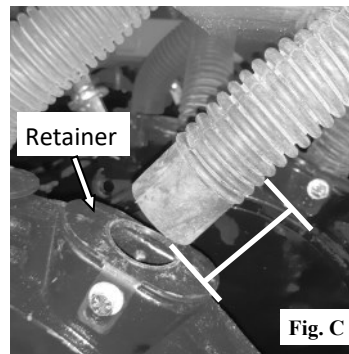

It is easier to insert the Fertilizer/seed tube by folding the end of the seed tube as shown, Fig. D.



Installed Fertilizer/seed tube, Fig. E.

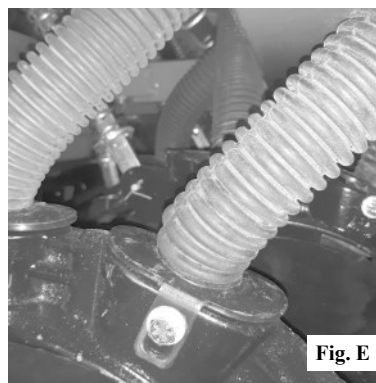

Assembly

Step 6:

Install A frame on inside of mounts.



Step 7:

The Seed Rate Handle is turned in for “Transport” purposes. Before operating the machine, remove the nut from the handle, flip the handle to face away from the seeder, thread nut on handle and tighten before making adjustments to the seeder.



Handle in Transport Position

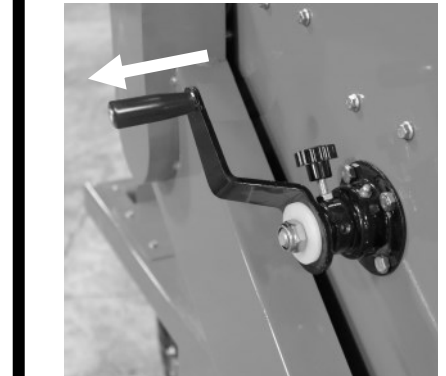

Handle in Work Position

Operating Instructions

Before beginning work:

- Be sure all the seed cups completely close and open the same, so all cups are putting out the exact amount of seed. If they are not in sync, one cup will put out more than others.
- Ensure when completely closed, the seeding gears are not protruding from the outside the cup.
- Adjust the clamps to ensure all cups close and open completely and uniformly.

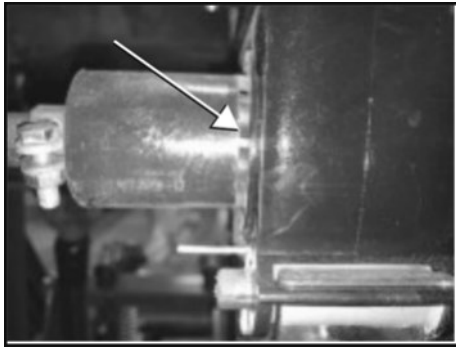

NOT FLUSH—GEARS PROTRUDING

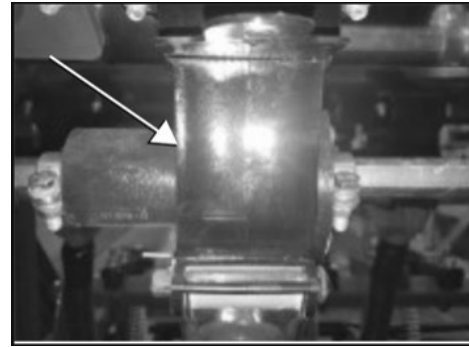

FLUSH—GEARS NOT PROTRUDING

To adjust seed output:

The Seed cups on the SAYA may come with either of two different style of seed cups or a combination of both. Typically the front Seed box section is equipped with a LARGE SEED CUP and the rear section typically has the LEGUME SEED BOX.

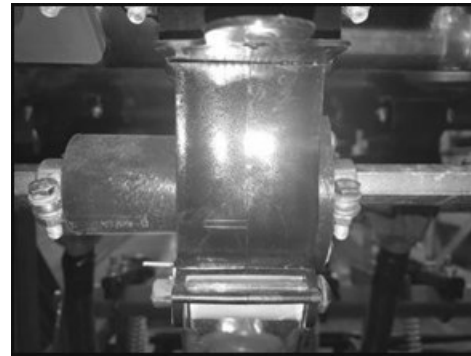

The LARGE SEED front section is usually driven with an 11-26 Gear ratio, while the back LEGUME SEED section is being reduced to put out less with a 12-40 Gear Ratio.



Large seed cup box - front



Legume seed cup box - rear

Operating Instructions

Seeding/Fertilizing rate adjustment handle:

To adjust the seed/fertilizer rate, loosen the Locking Knob before attempting to adjust the feed rate. Note that the Locking Knob sits in a groove on the Adjustment Handle. Loosen the Locking Knob to the point where it clears the threads of the Adjustment Handle. When tightening the Locking Knob, be sure it sits in the groove or the threads can be damaged. See the Decal located on the machine near the Adjustment Handle for more information. The seed/fertilize rate depends on the seed/fertilizer you want to plant, please refer to your seed/fertilizer supplier's chart to get the proper seed/fertilize rate.

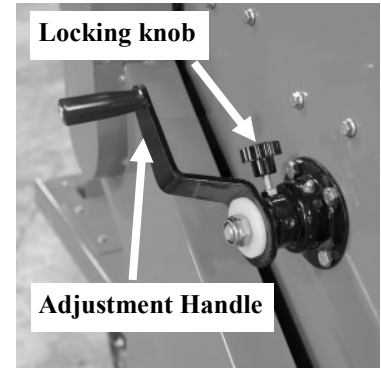

Before adjusting the seed rate, return the rate on the Scale to zero by cranking the Adjustment Handle, then check and make sure all seeding/fertilizing wheels are fully closed on all seeding/ fertilizing boxes. (SEE BEFORE BEGINNING section) If not, you need to loosen the clips on both sides of the seeding/fertilizing wheel and push the wheel into the box. Tighten the clips. When the seeding/ fertilizing box is closed and the meter indicates "0". Adjust fertilizing rate by cranking the Adjustment Handle. The meter has 8 numbers from 0-8, from zero to Maximum.

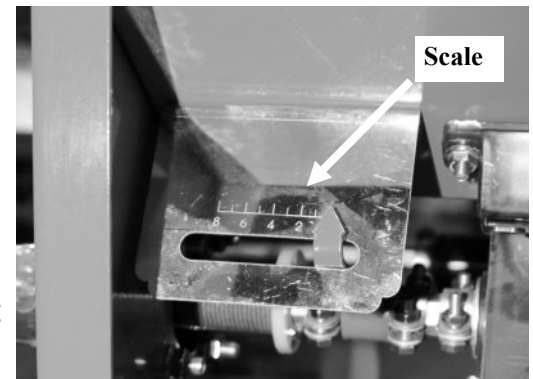

Weight, size, relative humidity, and moisture content can affect seeding rates. Users can adjust the position of the seed/fertilizer "TONGUE" and lock in different positions by moving the cotter pin to meet the different seeding/fertilizing size. The smaller the seed, the higher up the "TONGUE" should be positioned. For larger seed, the "TONGUE" should be opened more.

Positioning holes

Tongue and positioning holes



Important: Tighten Locking Knob on Adjustment Handle before operating.

Operating Instructions

Seed cup shutoff:

Depending on the crop being planted, it may be necessary to not disburse from all of the seed cups. This is easily done by simply sliding the “Seed shut off flap” in and out.

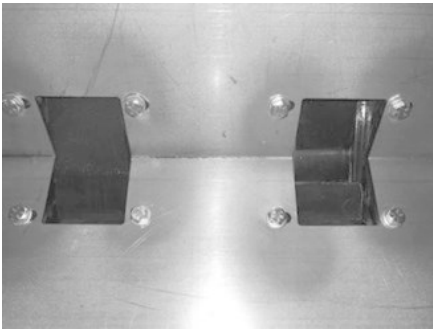

Closed

Open

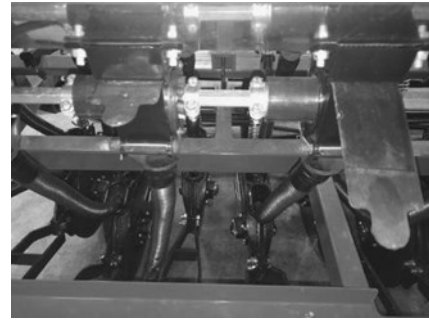

Closed

Open

Rear Roller Adjustment

Turning Rear Roller Adjustment Wheel counter-clockwise will lower the roller to engage the ground. **Note: Adjusting too low will raise the disc openers and lessen the depth.** Turning the knob clockwise will raise the rear roller wheel.

The rear roller should be adjusted so that there is enough contact with the ground to drive the machine.

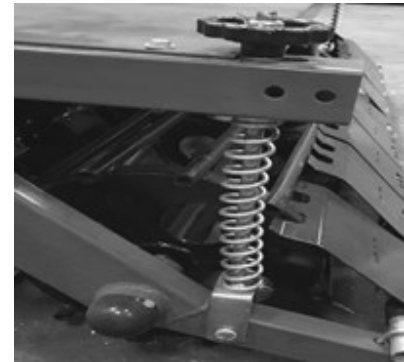

Seed depth - Torsion Bar Wheel

Turning the Torsion Bar Wheel counter-clockwise will increase spring tension on the individual discs to apply additional pressure on the seed wheels, allowing deeper ground penetration.

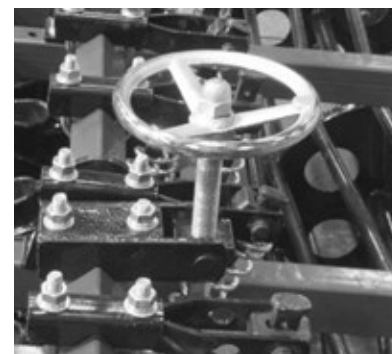

Operating Instructions

Seed depth - Disc Support Bar

The top link on the tractor hitch should be properly adjusted to carry the machine level in an operating position. During operation, the tractor lift must be fully lowered to allow the machine to follow the contour of the ground.

Additional pressure can be added by moving the curved clip into another hole on the Disc Support Bar.

The machine is totally ground driven so proceed with a speed that is most comfortable and safe for existing conditions. Be sure to stop forward motion before lifting the machine off the ground. This practice will stop rollers from “free spinning” and therefore eliminate the unwanted application when turning around. Never operate the machine in reverse.



Important: The machine comes equipped with additional weight platforms to help penetrate harder soils. Do not overload!

Additional weight platform



Warning: Never backup with the machine on the ground! This will cause damage to the machine. Always lift the machine high enough to clear the ground before backing up.

Adjusting Disc Alignment

Disc Alignment:

The Disc Support Bracket must be in the correct orientation prior to operating the machine. The corners of the Disc Support Bar must be in the 12 O'clock, 3 O'clock, 6 O'clock & 9 O'clock positions. The Disc Support Bracket will be parallel to the ground, **Fig. "A"**.

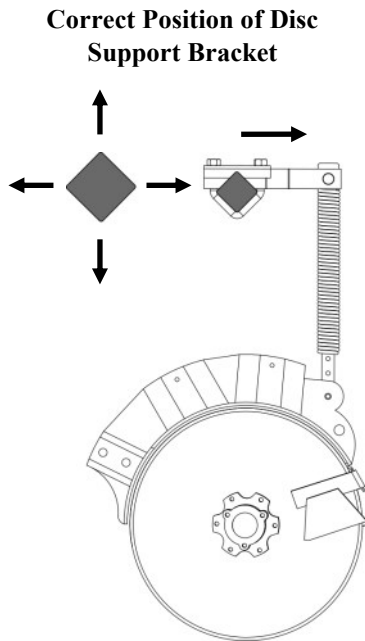

Fig. "A"

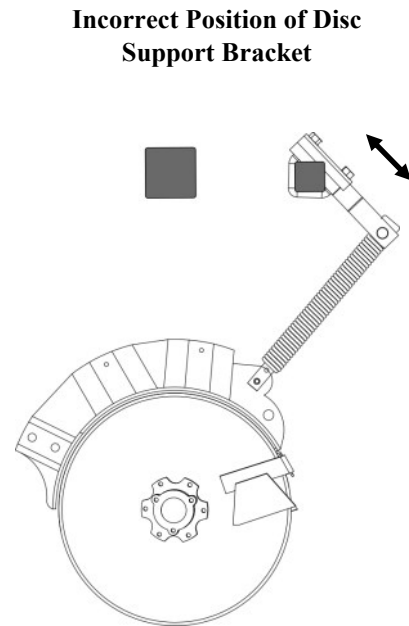

Fig. "B"

If the Disc Support Bracket is not parallel to the ground, as shown in **Fig "B"**, disconnect the Disc Support Brackets and Torsion Bar Clamp, **Fig "C"**.

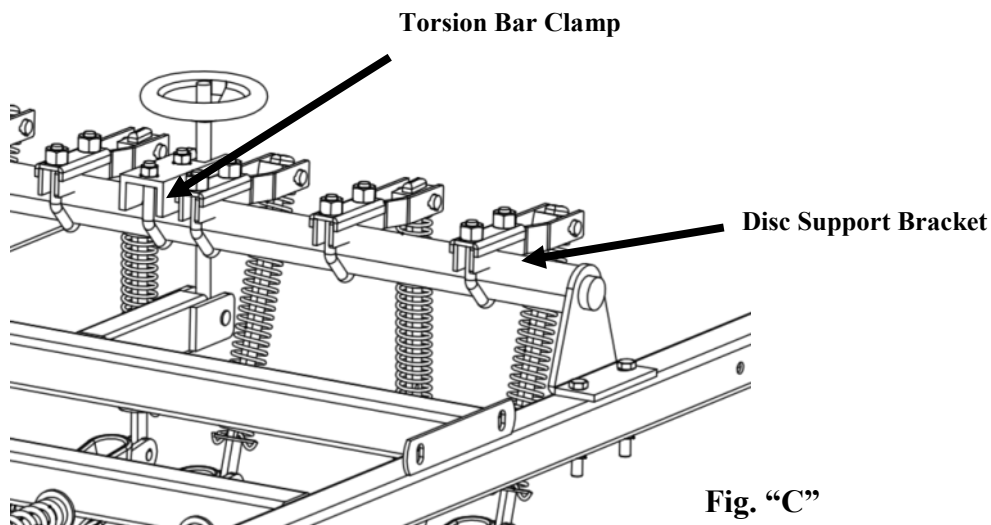
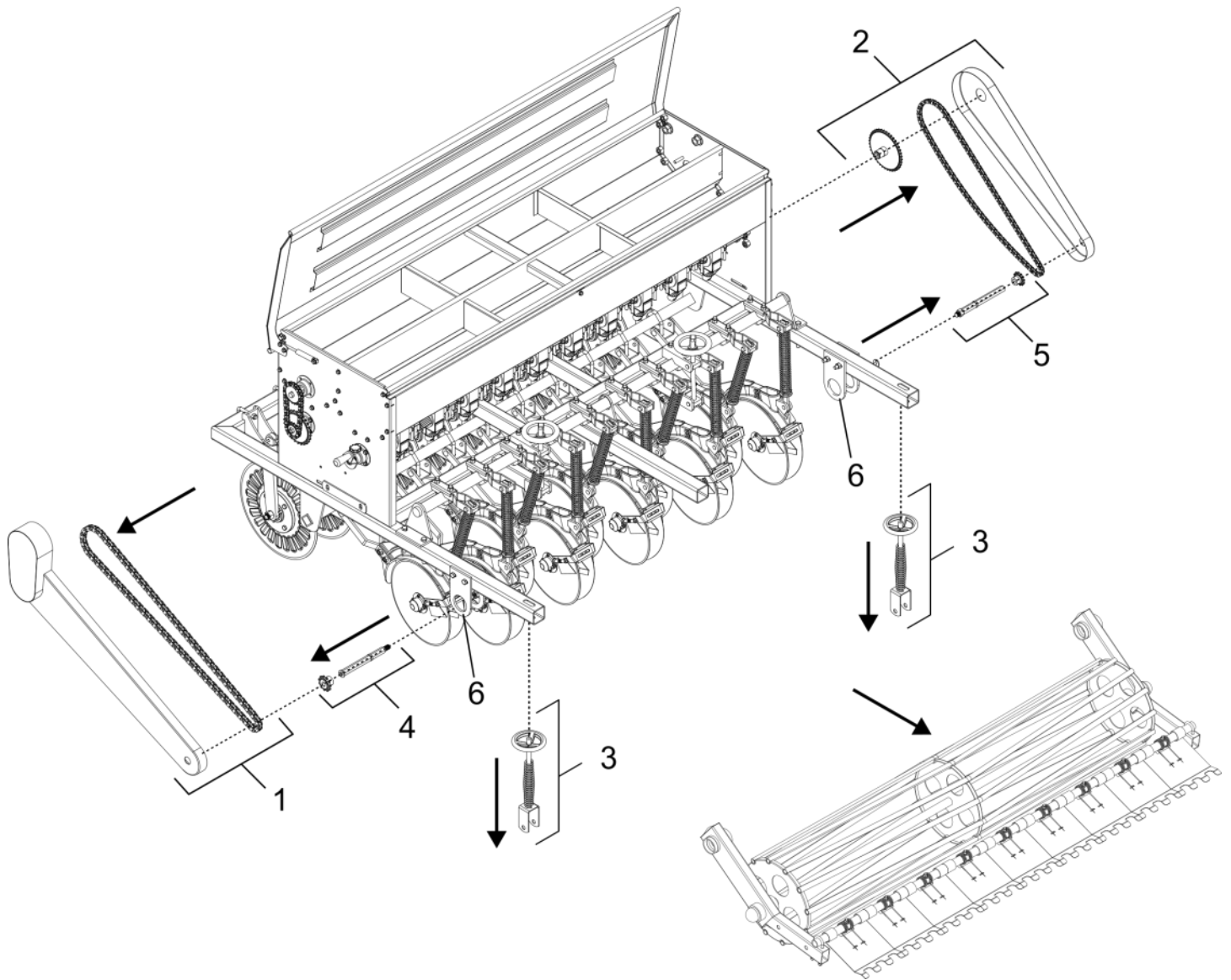

Fig. "C"

Optional Cast Iron Roller Instructions



Optional Cast Iron Roller Instructions



WARNING! Prior to removing parts from the machine or installing the Optional Cast Iron Roller, take all necessary precautions to ensure the safety of the installer(s). Wear necessary PPE (personal protection equipment). It is advised to perform the work on a hard, level surface, such as a concrete shop floor or other hard appropriate surface. Never allow bystanders in work area or between the tractor and machine. If the machine is attached to a tractor, shut off the engine, remove key, set parking brake and block the wheels of the tractor to prevent movement. Serious injury or death can occur!

Removal of Original SAYA-505/507 Parts.

Note: Original parts removed from the machine should be stored in dry location in case the Cast Iron Roller Kit is removed at any point and the Original Roller is re-installed.

Step 1. Remove LH Roller Chain Cover and LH Roller Chain.

Step 2. Remove RH Roller Chain Cover, RH Roller Chain and 40 Tooth Chain Sprocket.

Step 3. Remove one of the Downforce Adjustment Assemblies by first removing the Locking Nut and Roller Downforce Adjustment Wheel. Next remove the M16x70 Shoulder Pin and Cotter Pin from the lower part of the assembly. The Downforce Adjustment Assembly can then be slide out from the SAYA Frame. Repeat for the other side.

Step 4. Remove LH Drive Sprocket and Small Sprocket Shaft from the LH Roller Arm. These parts must be removed prior to removing Roller Assembly. *(Note: The Small Sprocket Shaft is re-used for the Cast Iron Roller Install).*

Step 5. Remove RH Drive Sprocket and Small Sprocket Shaft from the RH Roller Arm. These parts must be removed prior to removing Roller Assembly. *(Note: The Small Sprocket Shaft is re-used for the Cast Iron Roller Install).*

Step 6. Loosen (*do not remove*) Bracket Roller Arm Brackets securing the Roller Assembly to the Frame. At this point in time, the Roller Assembly can be removed from the machine.

Optional Cast Iron Roller Instructions

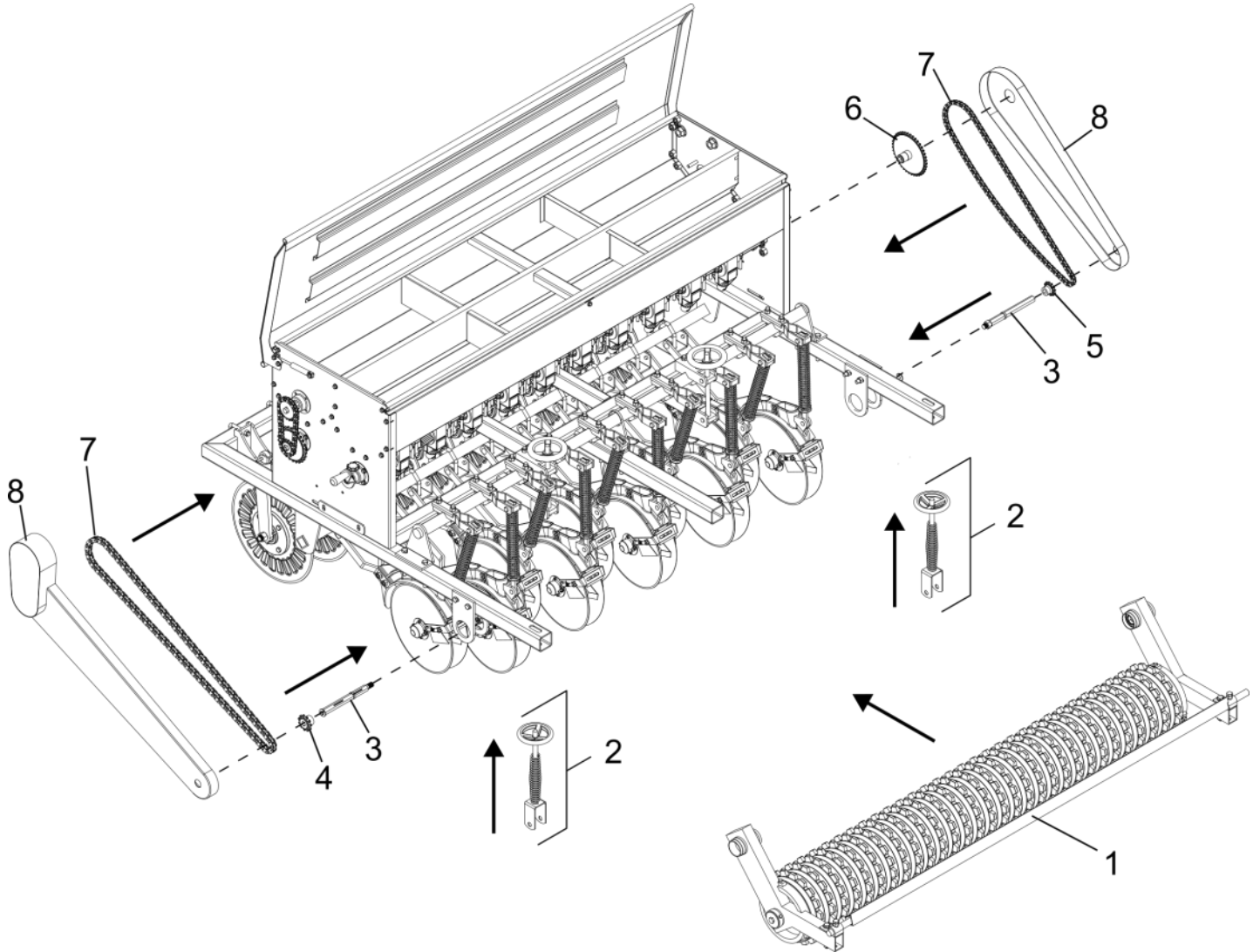

Optional Cast Iron Roller Instructions

Installation of Cast Iron Roller SAYA-505/507

Note: Do not tighten hardware until all parts are in place and aligned.

Step 1. Move the Cast Iron Roller Assembly in place, lining up the Roller Arms with the Roller Arm Brackets. Leave Roller Arm Brackets loose for now.

Step 2. Attach the Downforce Adjustment Assemblies (original part) to the SAYA Frame and Roller Arms.

Step 3. Insert (1) Small Sprocket Shaft (original part) in the each of the Roller Arms.

Step 4. On the LH Roller Arm, slide Sprocket *SA4114 9Tooth, #50 Chain on the Small Sprocket Shaft. Do not tighten at this time.

Step 5. On the RH Roller Arm, slide Sprocket *SA4112 10Tooth, #40 Chain on the Small Sprocket Shaft. Do not tighten at this time.

Step 6. Attach *SA4108 Sprocket, 45T to the RH side of the machine.

Step 7. Attach #50 Roller Chain to the LH side of the machine and #40 Roller Chain to the RH side of the machine. Note: Both LH and RH chains have to be extended due to larger sprockets. Extra links, half links and master links are included in the Cast Iron Roller Kit. Once Sprockets, Chain are in alignment, lock down Sprockets.

Step 8. Replace the LH and RH Roller Chain Covers.

Step 9. Tighten all hardware to proper torque specs. A torque chart is included in the SAYA Operator's Manual.

***Parts included in Cast Iron Roller Kit**

Lubrication and Maintenance

Important: It is important to thoroughly clean the seeder after use. Failure to do so can cause irreparable damage to the seed cups and drive system. Grease and turn the Seed adjustment handle to ensure grease lubricates the threads.

There are a few ways to clean out the hoppers:

- Each hopper is equipped with a cleanout spout in the front of each hopper.
- The rear hopper is equipped with a quick release lever located under the center of the hopper. By pulling down the lever, all the hopper tongues will open and cause the seed/fertilizer to drop out of each of the seed cups.
- Each seed cup can be emptied individually by pulling the cotter pin on the side of the cup and dropping down the hopper tongue.

1 Hour Check all fasteners and hardware including set screws in sprockets and bearing collars and re-tighten as necessary.

8 Hours Grease bearings on roller and apply grease to torsion bar wheel mechanism.

As needed: Remove any crop residue, grasses, weeds, or debris wrapped around shaft discs or rollers. This can cause bearings to overheat and lead to premature failure.

Always: Protect the machine from weather. NEVER leave fertilizer in hopper. Do not leave seed in hopper for more than 24 hours. Remove all fertilizer and seeds from hopper. Thoroughly clean hoppers and lubricate all drive chains before storage.

Changing Discs

Important: When replacing the discs, it is extremely important to remember that one of the disc hubs has left hand threads and the other right hand threads. The threads can be stripped if removed improperly. Left side hub, turn Clockwise to loosen and turn counter-clockwise to tighten. Right side hub, turn counter-clockwise to loosen and clockwise to tighten.

Step 1: Remove the dust cap.

Step 2: Remove the external scraper dust cap.

Step 3: Remove hub nuts.

Step 4: Unscrew the hub from the disc support.

Step 5: Replace the discs and reassemble.

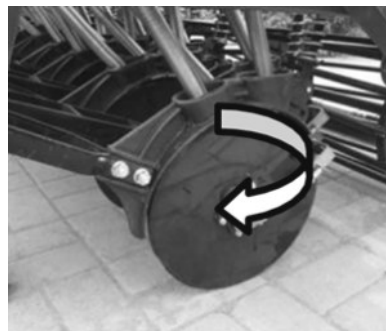

Important: When replacing the discs, it is extremely important to remember that the left disc hub has reverse (LH) threads. The right disc hub has normal (RH) threads. If turned incorrectly, they can strip.

Lubrication and Maintenance



Warning! When removing/replacing SA4027 Stud, disc assembly LH / SA4028 Stud, disc assembly RH, note that the LH & RH studs have different thread patterns! Using the wrong stud will cause damage to the stud and or the seed drill casting!

Instructions for Removing/Replacing Disc Studs

SA4027 Stud, disc assembly LH has LH threads on both ends of the stud. *SA4028 Stud, disc assembly RH* has RH threads on both ends of the stud. These parts are **not interchangeable!** The LH stud must be used on the LH side of the Seed drill casting. The RH stud must be used on the RH side of the Seed drill casting.

Removing Disc Assembly studs:

LH - Facing the LH side of the Disc Assembly, turn the nut on the stud in a clockwise rotation.

RH - Facing the RH side of the Disc Assembly, turn the nut on the stud in a counter-clockwise rotation.

Re-attaching Disc Assembly studs:

LH - Facing the LH side of the Disc Assembly, turn the nut on the stud in a counter-clockwise rotation.

RH - Facing the RH side of the Disc Assembly, turn the nut on the stud in a clockwise rotation.

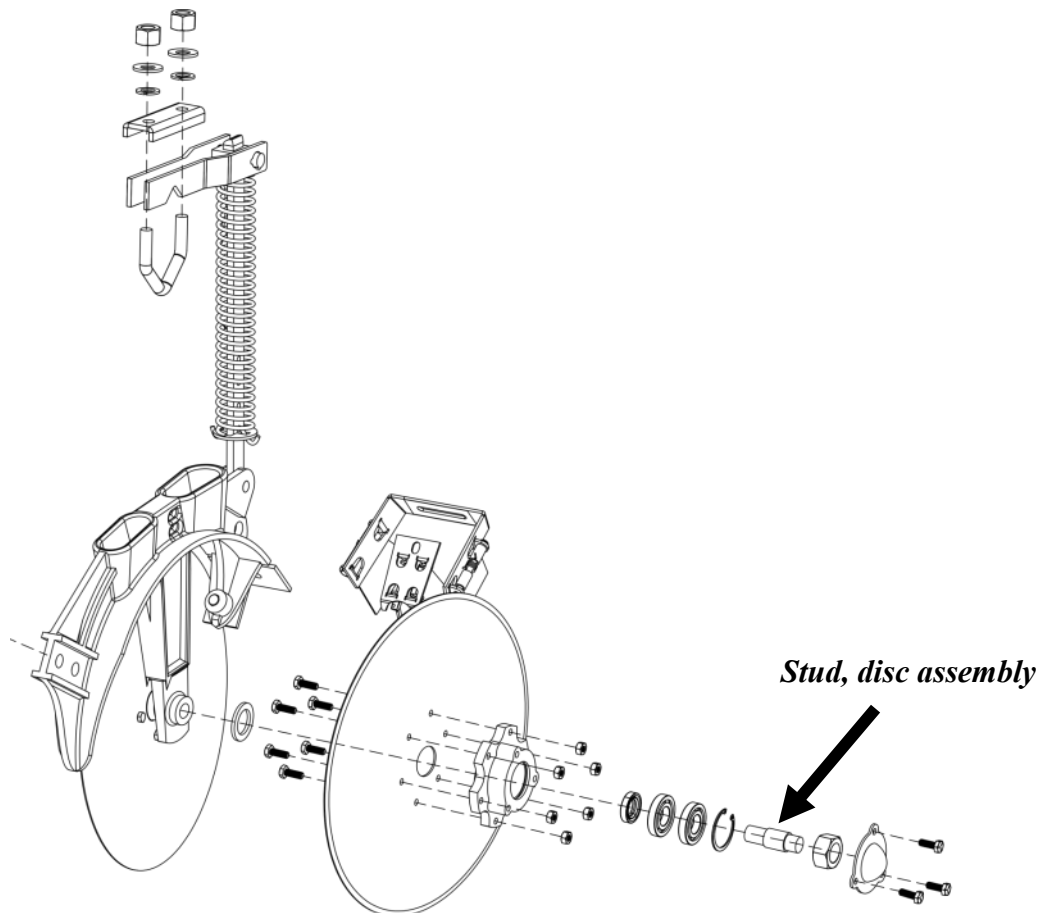

Setting Application Rates

The most accurate way to set application rates is to drive a predetermined distance and physically catch the seeds dispensed. To do this, remove at least one drop hose and tie a plastic bag onto bottom of seed cup. Travel a determined distance and then weigh the seeds in the bag. Multiply the amount collected by the number of cups on your machine. Refer to the following example to properly calibrate your machine.

To determine area covered calculate the following:

Disc spacing x number of discs (7 or 10), (convert to ft.) x distance traveled / by the sq. ft. in an acre.
 Ex. 10 discs with a 7.5" spacing = 75" (6.25 ft.) x 100 ft. traveled = 625 sq. ft. covered.
 $625 / 43,560 \text{ sq. ft. in acre} = .0143$ (1.43% of acre covered.)

If you collect 1 oz. of seed from a single seed cup on the #3 setting after driving 100 ft. (1.43% of an acre), you are putting out 43.70 lbs. per acre.

1 oz. (amount collected) x number of seed cups (7 or 10)
 Ex. 10 seed cups = 10 oz. total output by machine. Distance traveled = 100 ft. (1.43% of acre)
 $1 \text{ oz} / 16 \text{ oz (16 oz in 1 lb.)} = .0625 / .0143 = 4.37 \times 10 \text{ disc} = 43.70 \text{ lbs. per acre}$

NOTE: The tables and rate charts are guidelines only! They are designed to be an aid as a starting point. You must do your own calibration as many factors cause rates to change. Variations in seed/ granular size, density, moisture, seed treatment, and the amount of machine overlap will affect the final application rate.

See next page for "Application Rate Charts".



Application Rate Charts

LARGE SEED CUP 11-26 Gear Ratio

Cup Setting	1/2	1	2	3	4	5
Chufa				40	50	
Oats				65		125
Wheat				60	90	120
Lawn Mixtures					100	130
Fescue					114	138
Rye			72			
Pelletized Lime		50				
Shut off every other seed cup						
Sunflower 15" row				22	32	
Soybeans 15" row			50			
Shut off every other 2 seed cups						
Corn 22.5" row				20	35	

Approximate Pounds Per Acre

25.5 rotations of the drive roller = 100 Feet

SMALL SEED CUP 12-40 Gear Ratio

Cup Setting	1/2	1	2	3	4	5
<u>Clover/Brassica/Rape</u>	6					
Sorghum/Millet		15		30		
Alfalfa			20			
Buckwheat				50		
Timothy Grass		(1.5 = 10)	15			
Kentucky Blue Grass				30	40	
Radish		10				
Turnips		11				
Rye		7				
Chicory		5				
Alfalfa/Chicory(Food Plot Mix)		10.5				

Approximate Pounds Per Acre

25.5 rotations of the drive roller = 100 Feet

Torque Specifications

Torque Specifications for Common Bolt Sizes															
Inches		Bolt Head Identification						Metric		Bolt Head Identification					
										5.8		8.8		10.9	
Bolt size (inches)	Thread pitch	Grade 2		Grade 5		Grade 8		Class 5.8		Class 8.8		Class 10.9			
		N.m	ft-lb	N.m	ft-lb	N.m	ft-lb	N.m	ft-lb	N.m	ft-lb	N.m	ft-lb		
1/4"	20	7	5	11	8	16	12	M5	0.08	4	3	6	4	9	7
1/4"	28	8	6	13	10	19	14	M6	1	6	4	10	7	15	11
5/16"	18	15	11	24	17	33	25	M8	1.25	16	12	25	18	36	27
5/16"	24	17	13	26	19	37	27	M8	1	17	13	26	19	38	28
3/8"	16	27	20	42	31	59	44	M10	1.5	31	23	48	35	71	52
3/8"	24	31	23	47	35	67	49	M10	1.25	33	24	51	38	75	55
7/16"	14	43	32	67	49	95	70	M10	1	35	26	53	39	78	58
7/16"	20	48	36	75	55	106	78	M12	1.75	54	40	84	62	123	91
1/2"	13	66	48	102	75	144	106	M12	1.5	56	41	87	64	128	94
1/2"	20	75	55	115	85	163	120	M12	1.25	59	44	90	66	133	98
9/16"	12	95	70	147	109	208	154	M14	2	84	62	133	98	195	144
9/16"	18	106	79	164	121	232	171	M14	1.5	94	69	142	105	209	154
5/8"	11	132	97	203	150	287	212	M16	2	131	97	206	152	302	223
5/8"	18	149	110	230	170	325	240	M16	1.5	141	104	218	161	320	236
3/4"	10	233	172	361	266	509	376	M18	2.5	181	133	295	218	421	310
3/4"	16	261	192	403	297	569	420	M18	2	196	145	311	229	443	327
7/8"	9	226	167	582	430	822	606	M18	1.5	203	150	327	241	465	343
7/8"	14	249	184	642	473	906	668	M20	2.5	256	189	415	306	592	437
1"	8	339	250	873	644	1232	909	M20	1.5	288	212	454	335	646	476
1"	12	371	273	955	704	1348	995	M22	2.5	344	254	567	418	807	595
1-1/8"	7	480	354	1077	794	1746	1288	M22	1.5	381	281	613	452	873	644
1-1/8"	12	539	397	1208	891	1958	1445	M24	3	444	327	714	526	1017	750
1-1/4"	7	677	500	1519	1120	2463	1817	M24	2	488	360	769	567	1095	808
1-1/4"	12	750	553	1682	1241	2728	2012	M27	3	656	484	1050	774	1496	1103
1-3/8"	6	888	655	1992	1469	3230	2382	M27	2	719	530	1119	825	1594	1176
1-3/8"	12	1011	746	2268	1673	3677	2712	M30	3.5	906	668	1420	1047	2033	1499
1-1/2"	6	1179	869	2643	1949	4286	3161	M30	2	1000	738	1600	1180	2250	1659
1-1/2"	12	1326	978	2974	2194	4823	3557	M36	4	1534	1131	2482	1830	3535	2607

Notes:

This chart is an approximate estimate of torque values.

Always tighten hardware to these values unless a different torque value or tightening procedure is listed for a specific application.

Fasteners must always be replaced with the same grade as specified in the manual.

Always use the proper tool for tightening hardware: SAE for SAE hardware and Metric for Metric hardware.

Make sure that fastener threads are clean and that you properly start thread engagement.



No Till Drill

SAYA-505 & 507



Parts Manual

SAYA-505, Serial #41243 & above

SAYA-507, Serial #62119 & above

Hopper Assembly

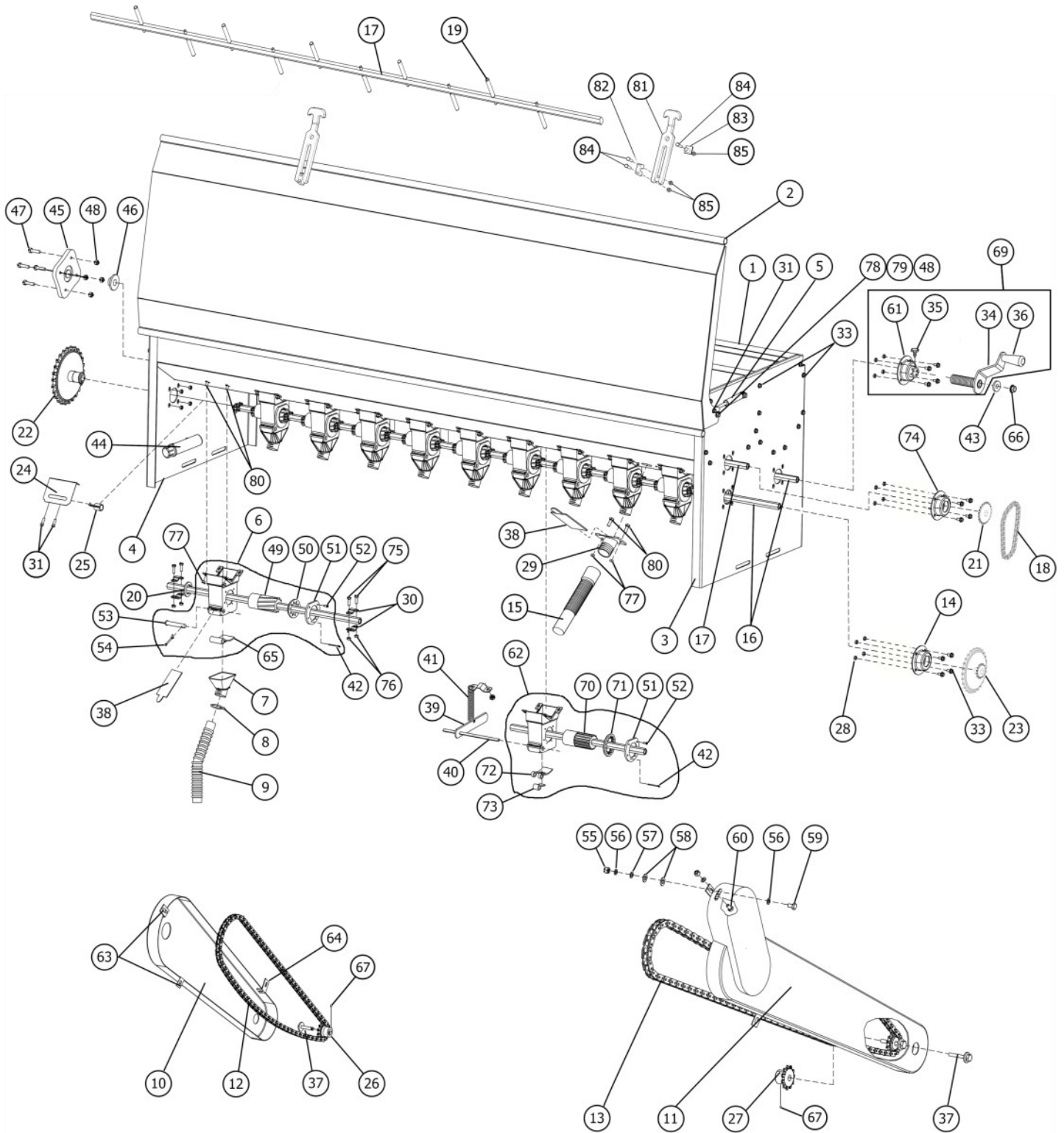

Hopper Assembly

Item	Part #	Description	Qty.
1	SA1003-55	Hopper complete with lid and seed cups - SAYA-505	1
	SA1003-78	Hopper complete with lid and seed cups - SAYA-507	1
2	SA1001-55	Hopper lid; SAYA-505	1
	SA1001-78	Hopper lid; SAYA-507	1
3	SA1004	Hopper end plate, LH	1
4	SA1005	Hopper end plate, RH	1
5	DL5003	Lid piston	2
6	DL7001-L	Seed cup distribution box complete large seed (<i>Refer to Note 2, Page 37</i>)	-
7	DL7006	Seed cup funnel	-
8	SA9005	Tube wire clamps	-
9	SA3002	Fertilizer/seed tube	-
10	SA10005	Right chain cover	1
11	SA10004	Left chain cover	1
12	SA3004B	Chain (#40) rear hopper, 127 links	1
13	SA3004A	Chain (#50) front hopper, 126 links	1
14	DL1005	Flange assembly w/bearing	2
15	DL7008	Waste tube	-
16	SA10001-55	Hex seed box shaft; SAYA-505	2
	SA10001-78	Hex seed box shaft; SAYA-507	2
17	SA9010-55	Agitator rod, SAYA-505	1
	SA9010-78	Agitator rod, SAYA-507	1
18	SA3003	Chain, agitator	1
19	SA9011	Fingers & nuts, agitator	-
20	FW18	Washer flat M18	20
21	SA9012	Drive sprocket, agitator 20T	1
22	DL2003	Drive sprocket Z40	1
23	SA4032	Double sprocket 14T/26T	1
24	DL7004A	Rate adjustment face plate (front) (<i>Refer to Note 1, Page 37</i>)	1
	DL7004B	Rate adjustment face plate (rear) (<i>Refer to Note 1, Page 37</i>)	1
25	DL7005	Counter pointer	2
26	DL3005A	Drive sprocket Z12	1
27	DL5005B	Drive sprocket Z11	1
28	LN0610	Lock nut M06x1.0	252
29	DL1006	Cleanout spout	2
30	DL7002	Distribution box clamp	-
31	BM061016	Bolt HH M06-1.0x16	2
32	BM0812535	Bolt HH M08-1.25x35	4
33	BM061012	Bolt HH M06-1.0x12	131

Hopper Assembly

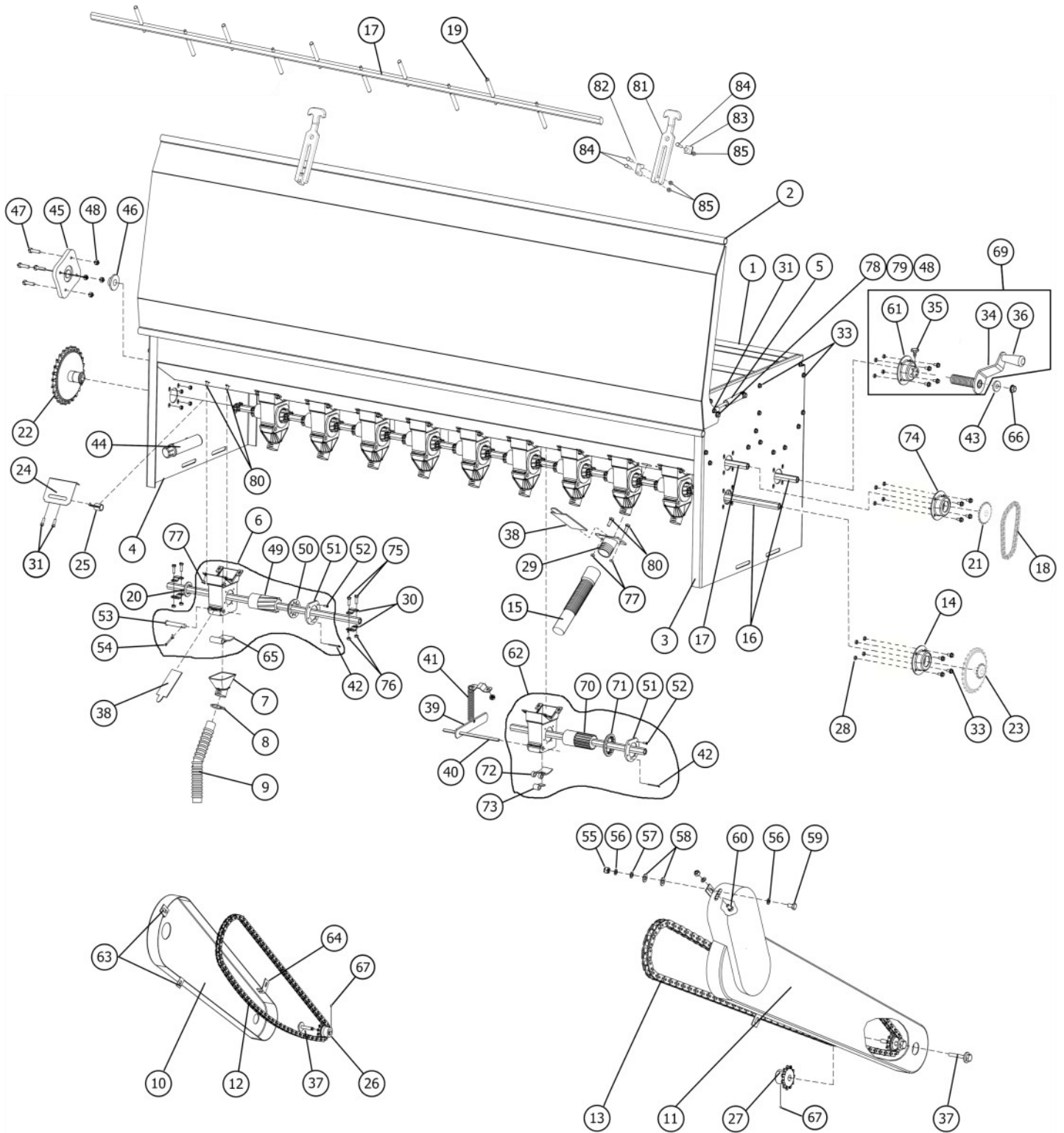

Hopper Assembly

Item	Part #	Description	Qty.
34	SA2005	Handle assembly	2
35	SA2005K	Locking knob	2
36	SA5005K	Spinning adjustment handle with hardware	1
37	BM0812540	Bolt M08-1.25x40	2
38	DL7007	Waste/Seed/Fertilizer shut off flap	-
39	DL5006	Handle, clean out	1
40	SA4056	Clean out rod, SAYA-505	1
	DL4006	Clean out rod, SAYA-507	1
41	DL5007	Spring, clean out	1
42	CP3x70	Cotter pin M3x70	-
43	SA8009	Plastic washer, agitator handle	2
44	MH20000	Manual holder	1
45	SA9009	Mount, agitator	1
46	SA9007	Bushing, agitator	1
47	BM0812530	Bolt HH M08-1.25x30	4
48	NM08125	Nut HH M08-1.25	4
49	SA4012	Seed box shaft, spiral spline (front seed box)	10
50	SA4014	Shaft guide, seed cup - spiral spline	-
51	SA4015	Shaft guide retainer, seed cup	-
52	SA4021	Sheet metal screw	-
53	SA4019	Clevis, composite M10x60	-
54	CP2.5x20	Cotter pin M2x20	-
55	LNLM1015	Nut self-locking M10x1.50	6
56	LW10	Washer lock M10	4
57	FW10	Washer flat M10	8
58	SA4018	Washer rubber 2mm x 10 mm x 25 mm	8
59	BM101525	Bolt HH M10-1.50x20	4
60	BM101515	Bolt HH M10-1.50x15	6
61	SA4020	Handle flange	2
62	DL7001-S	Seed cup distribution box, small seed (<i>Refer to Note 2, Page 37</i>)	-
63	SA4016	Chain guard bracket, short (attach chain guard to hopper)	4
64	SA4017	Chain guard bracket, long (attach chain guard to rear frame)	2
65	SA4022	Flap, seed cup	-
66	LNLM1420	Self-locking nut M14-2.0	2
67	MSTSC0816	Set screw M8-1.25x16	2
68			
69	DL2005	Handle complete	2
70	SA4013	Seed box shaft, straight spline (rear seed box)	-
71	SA4029	Shaft guide, seed cup - straight spline	-

Hopper Assembly

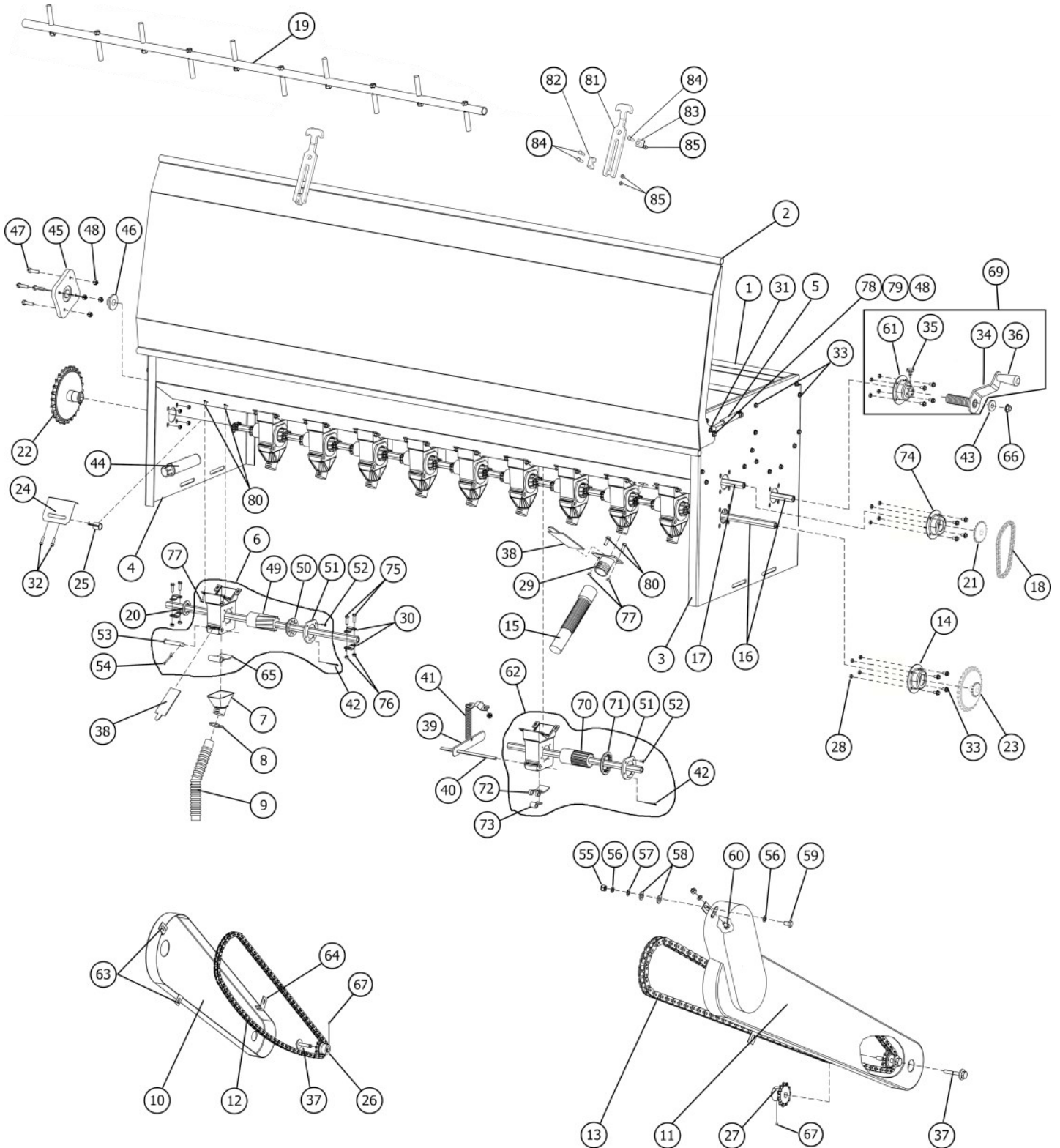

Hopper Assembly

Item	Part #	Description	Qty.
72	SA4030	Flap outer	10
73	SA4031	Flap inner	10
74	SA4033	Agitator flange assembly w/bearing	1
75	BM061020	Bolt HH M06-1.0x20	-
76	NM0610	Nut HH M06-1.0	-
77	FNM0610	Flange nut HH M06-1.0	-
78	BM0812540	Bolt HH M08-1.25x40	2
79	FNM08125	Flange nut HH M08-1.25	2
80	FBM061016	Flange bolt HH M06-1.0x16	-
81	SA4063	Hopper lid strap	2
82	SA4064	Hopper lid strap retainer	2
83	SA4065	Hopper lid strap latch	2
84	BM040725	Bolt HH M04-0.7x25	6
85	FNM0407	Flange nut M04-0.7	6

Note 1

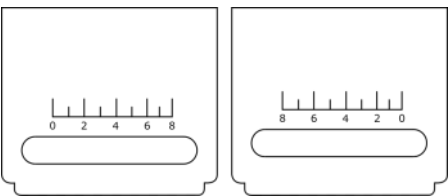

LH (rear)

RH (front)

Note: The Rate adjustment plates are not the same. LH plate faces the rear of the machine. The RH plate faces the front of the machine.

Note 2

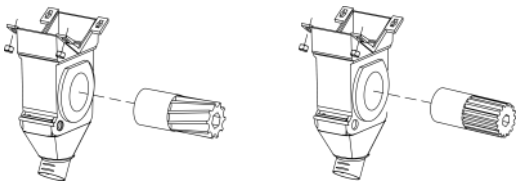

Front cup box

Rear cup box

Note: Front and rear seed cup boxes can be identified by examining the shafts. The front seed cup box has spiral splines while the rear has straight splines.

Frame Assembly

Item	Part #	Description	Qty.
1	SA4001-55	Frame; SAYA-505	1
	SA4001-78	Frame; SAYA-507	1
2	SA5001	Torsion lateral bracket	2
3	SA5002	Torsion bar center support	1
4	SA5000-55	Torsion bar; SAYA-505	1
	SA5000-78	Torsion bar; SAYA-507	1
5	SA5003	Torsion bar clamp bracket	2
6	SA4239	Spacer nylon 5x39x62	7/10
7	SA7001F	Disc assembly complete, front	7/10
8	SRI-60	Snap ring internal M60	14/20
9	SA7006	Seed drill casting, front	7/10
11	SA6002	Disc support bracket short, front	7/10
12	SA6004	Disc, single	14/20
13	B60042RS	Bearing 6004 2RS (2 per side)	28/40
14	SA6005	Disc support bearing (bearing only)	14/20
15	SA6009	Bearing grease cap	14/20
16	SA7003	V-bolt M12x1.75	7/10
17	BM1217550	Bolt HH M12-1.75x50	28/40
18	NM12175	Nut HH M12-1.75	28/40
19	SA7002	Disc spring for disc assembly	7/10
20	DL6007	External scraper	7/10
21	DL6006	Internal scraper	7/10
22	SA6011	Scraper mount bracket	7/10
23	BM0812520	Bolt HH M08-1.25x20	-
24	FNM08125	Flanged nut M08-1.25	-
25	DL11012	Flap 7.25"(SAYA-505; 1 pc / SAYA-507; 3 pcs) See Note, page 42	-
	DL11012A	Flap 8.25"(SAYA-505; 5 pcs / SAYA-507; 6 pcs) See Note, page 42	-
	SA4174	Flap w/slots 7.25"(SAYA-505; 1 pc / SAYA-507; 3 pcs) See Note, page 42	-
	SA4175	Flap w/slots 8.25"(SAYA-505; 1 pc / SAYA-507; 3 pcs) See Note, page 42	-
25A	DL11009	Spring, flap (NTGD-55; 6 pcs / NTGD-78; 9 pcs)	-
26	FW08	Flat washer M08	1
27	BM0812550PT	Bolt HH M08-1.25x50 partial thread	1
28	SA9006-55	Scraper board rod; SAYA-505	2
	SA9006-78	Scraper board rod; SAYA-507	2
29	DL8009	Adjustment rod shoulder pin M16x70	4
30	BM2025110	Bolt top hitch M20-2.5x110	4
31	DL8002-15	Roller downforce rod 380mm (15.00") (Check length prior to ordering)	2
	SA4061-16	Roller downforce rod 406mm (16.00") (Check length prior to ordering)	2
32	DL8004-11	Roller downforce rod spring 280mm (11.00")(Check length prior to ordering)	2
	SA1117-12.5	Roller downforce rod spring 318mm (12.50")(Check length prior to ordering)	2
33	DL8001	Roller downforce adjustment wheel	2
34	LNM1620	Self-Locking Nut M16 X 2.0 GALV	2

Frame Assembly

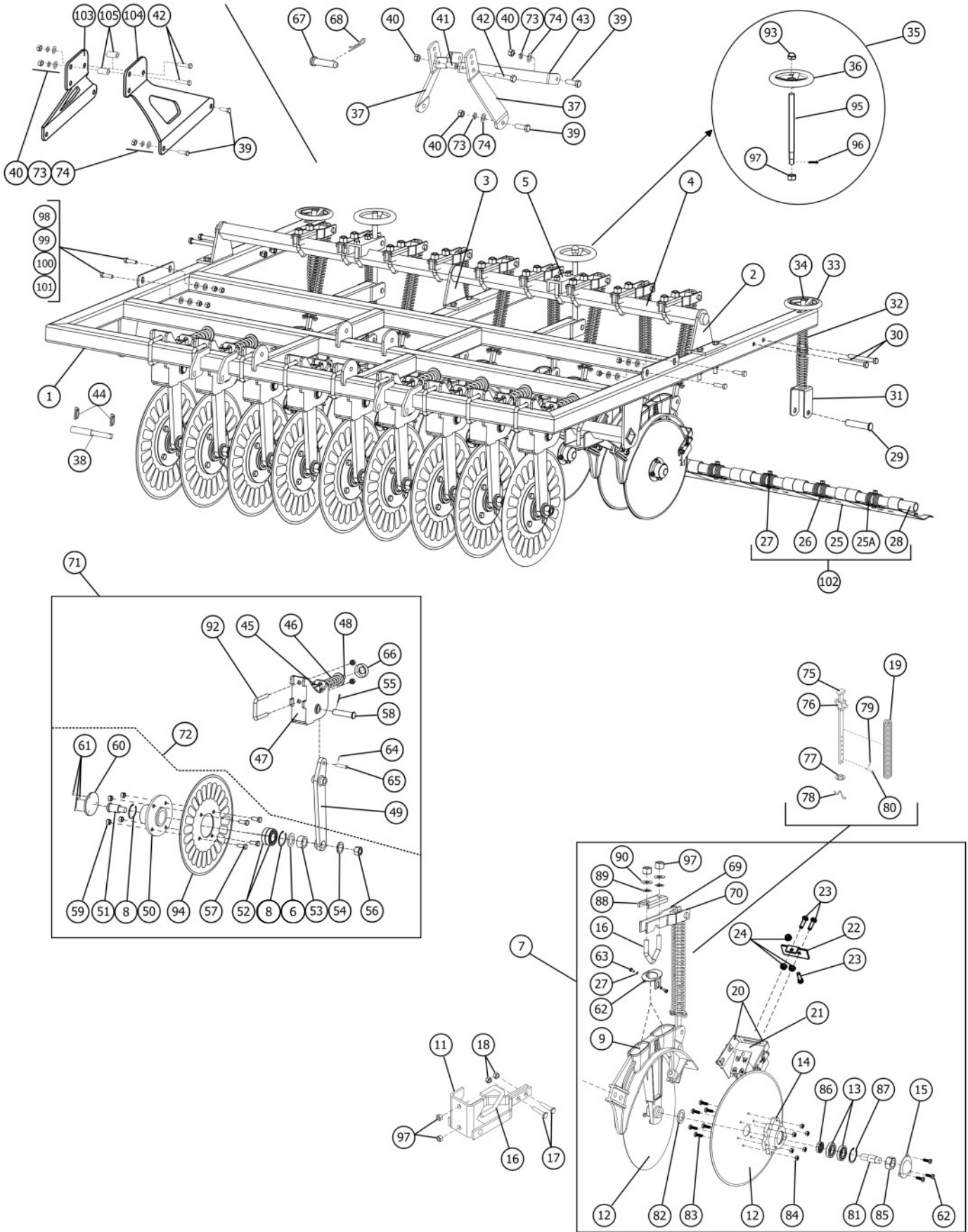

Frame Assembly

Item	Part #	Description	Qty.
35	SA4060	Adjustment shaft complete	2
36	SA9002	Adjustment shaft wheel	2
37	SA4009	A-frame vertical; SAYA-505&507	2
38	SA4059	Step pin Cat1/Cat2	2
39	BM182550	Bolt HH M18-2.5x50	4
40	NM1825	Nut M18-2.5	4
41	SA4006	A-frame spacer	1
42	BM1825110	Bolt HH M18-2.5x110	-
43	SA4003B	A-frame horizontal	2
44	LYNPN10	Lynch pin - M10	4
45	SA8005	Coulter spring arm	10
46	SA8004	Coulter spring	10
47	SA8001	Coulter support bracket	10
48	LNM1620	Self locking nut M16-2.0	10
49	SA8000	Coulter support arm	10
50	SA8003	Coulter bearing housing	10
51	SA8011	Special bolt	10
52	B62062RS	Bearing	20
53	SA9008	Spacer M30x42x9	7-10
54	FW20	Flat washer M20	7-10
55	CP5x40	Cotter pin M5x40	7-10
56	LNM2025	Nut lock M20-2.5	7-10
57	BM1217535	Bolt HH M12-1.75x35	40
58	SA8010	Lower hitch pin 20x90	40
59	LNM12175	Nut lock M12-1.75	40
60	SA9013	Cover	10
61	BM061012	Bolt HH M06-1.0x12	-
62	SA3001	Seed tube retainer	20
63	BM0812510	Bolt HH M08-1.25x10	40
64	CP3x35	Cotter pin M3x35	10
65	SA4010	Clevis pin M10x35	10
66	SA4008	Cap	10
67	SA4005	Pin	1
68	SA4011	R-clip M4	3
69	SA7004	Top coulter support bracket, left	1
70	SA7004R	Top coulter support bracket, right	1
71	SA8008R	Coulter Disc Assembly with Arm - Right	-
	SA8008L	Coulter Disc Assembly with Arm - Left	-
72	SA8007	Coulter disc w/o arm - SAYA	-
73	LW18	Washer lock M18	4
74	FW18	Washer flat M18	4
75	SA4023	Damper rod	-
76	SA4024	Damper guide	-

Frame Assembly

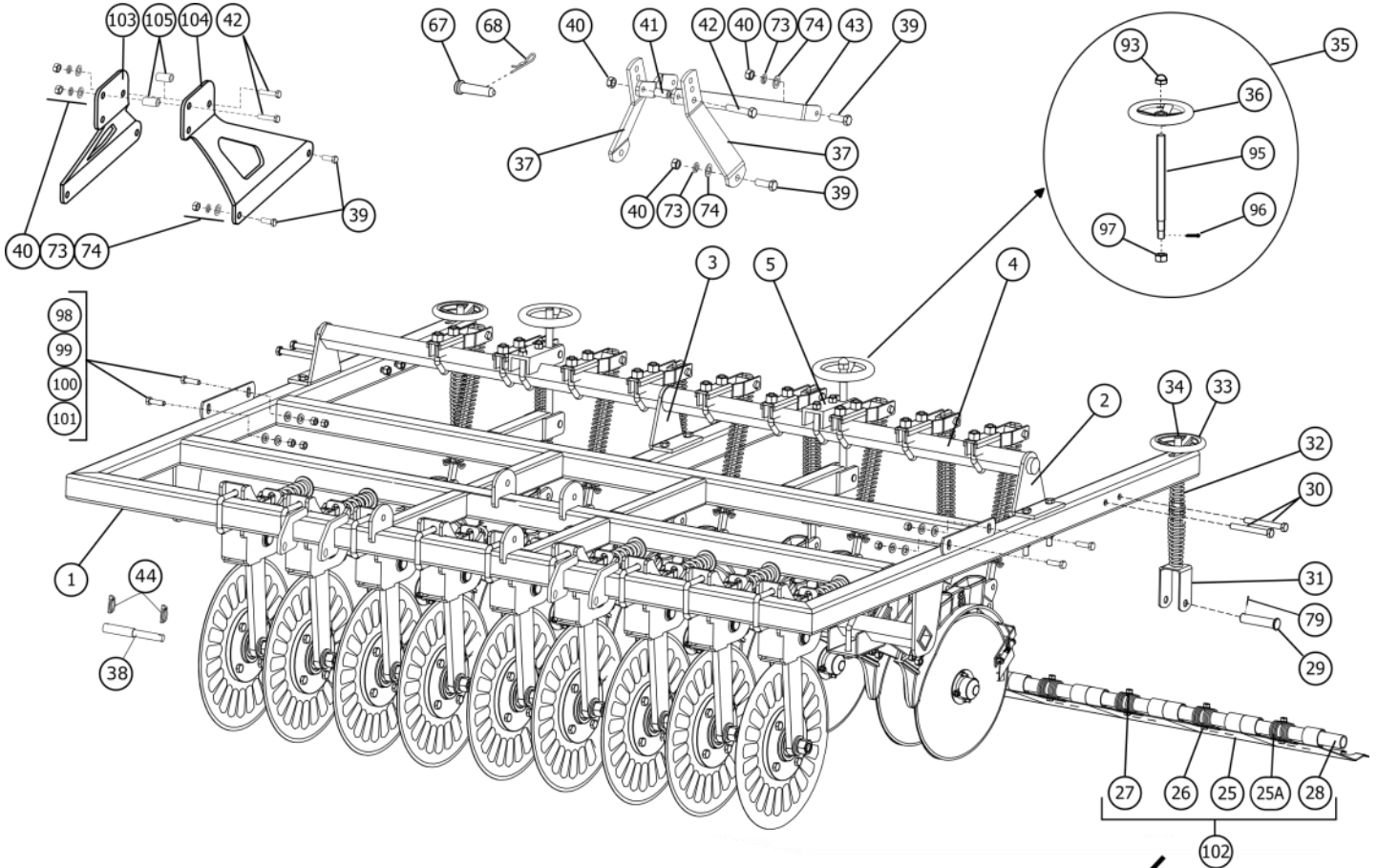

NOTE: There are two versions of the Scraper Board Flaps.
Prior to ordering replacement Flaps or Scraper Board Complete,
check the version of the machine.

Old Style

DL11012 →

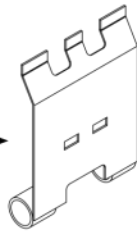

DL11012A →

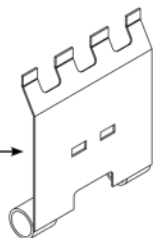

New Style w/Slots

SA4174 →

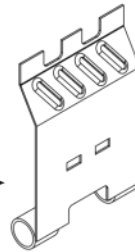

SA4175 →

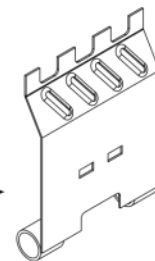

Frame Assembly

Item	Part #	Description	Qty.
77	SA4025	Star washer	-
78	SA4026	Retainer clip	-
79	CP3x25	Cotter pin M3x25	-
80	SA6010	Pin, clevis M6x40	-
81	SA4027	Stud LH, disc assembly *WARNING! See Page 21 before removing/replacing Studs	20
	SA4028	Stud RH, disc assembly *WARNING! See Page 21 before removing/replacing Studs	20
82	FW16	Washer flat M16	40
83	BM061025	Bolt HH M06-1.0x25	240
84	NM0610	Nut HH M06-1.0	240
85	TNM1620L	Thin hex nut M16-2.0 LH thread (for SA4027 LH stud only)	20
	TNM1620R	Thin hex nut M16-2.0 RH thread (for SA4028 RH stud only)	20
86	OS203207	Oil seal - M20x32x7	40
87	SRI-45	Snap ring - internal - M45	40
88	SA6003	Disc support	-
89	LW12	Lock washer M12	-
90	FW12	Flat washer M12	-
91	NM12175	Nut HH M12-1.75	-
92	SA8006	U-bolt	-
93	DNM1620	Dome (Cap) Nut - M16 x 2.0 GALV	2
94	SA8002	Coulter disc	-
95	SA4062	Adjustment shaft 467mm	2
96	CP2.5x20	Cotter pin	2
97	NM1420	Nut HH M14-2.0	2
98	CBM101530	Bolt carriage M10-1.5x30 (attach hopper to frame)	4
99	LFW10	Large flat washer M10 (attach hopper to frame)	4
100	LW10	Washer lock M10 (attach hopper to frame)	4
101	NM1015	Nut HH M10-1.5 (attach hopper to frame)	8
*102	SA4054	Scraper board complete - SAYA-505 (flaps, springs, rod, hardware)	1
	SA4055	Scraper board complete - SAYA-505 (flaps, springs, rod, hardware)	1
	SA4176	Scraper board complete, w/slotted flaps - SAYA-505 (flaps, springs, rod, hardware)	1
	SA4177	Scraper board complete, w/slotted flaps - SAYA-507, 907 (flaps, springs, rod, hardware)	1
103	SA4097	Hitch plate RH (SAYA505 Serial #50001+ / SAYA507 Serial # 70031+)	1
104	SA4098	Hitch plate LH (SAYA505 Serial #50001+ / SAYA507 Serial # 70031+)	1
105	SA4099	Spacer 27mm ODx20mm IDx45mm long (SAYA505 Serial #50001+ / SAYA507 Serial # 70031+)	2

***Refer to NOTE on Page 42 prior to ordering Item 102.**

Roller Assembly

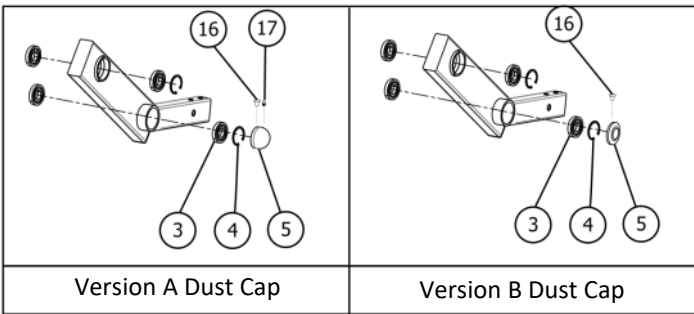
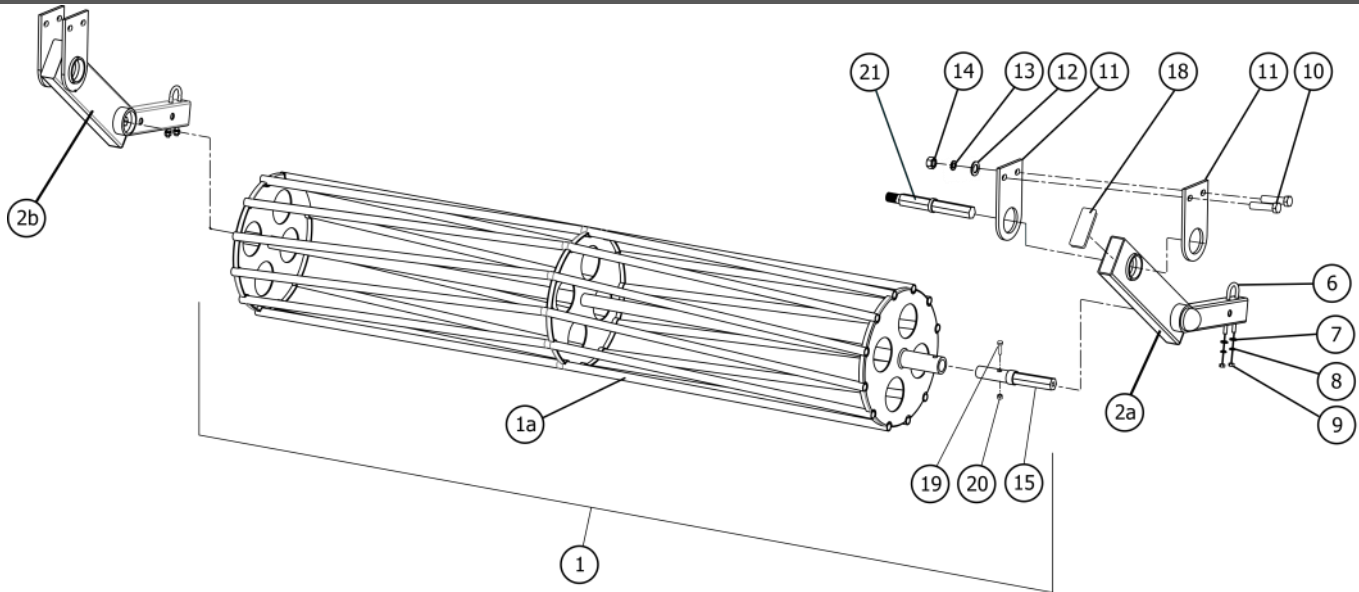

NOTE 1: The spindle on the Version ‘A’ roller is welded to the roller cage and can not be replaced. The Version ‘B’ spindle inserts in to the end of the roller cage and is held on with a bolt and nut. If for any reason the Version ‘A’ roller needs replacing, the Version ‘B’ roller complete (Item 1) is interchangeable.

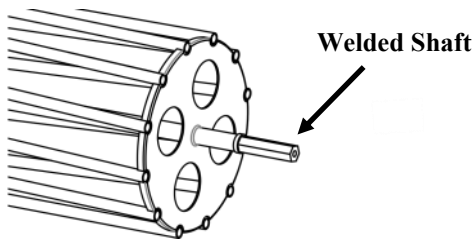

Version A

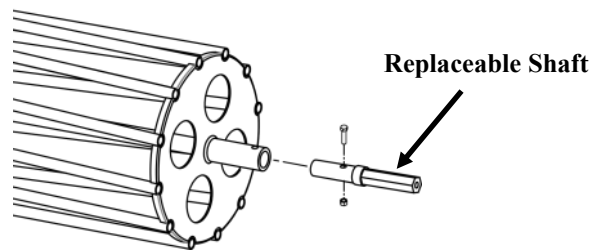

Version B

NOTE 2: If for any reason the roller arm needs replacing, please check the image below to determine your version, along with the serial number. These parts are not interchangeable.

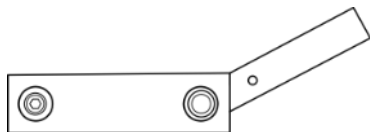

Version A

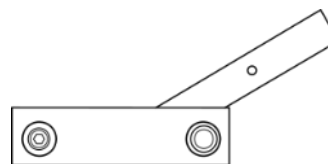

Version B

Roller Assembly

Item	Part #	Description	Qty.
1	SA9001-55	Drive roller complete; SAYA-505	1
	SA9001-78	Drive roller complete; SAYA-507	1
1a	SA4067	Drive roller; SAYA-505 (ROLLER ONLY - spindle, hardware not included)	1
	SA4068	Drive roller; SAYA-507 (ROLLER ONLY - spindle, hardware not included)	1
2a	DL8008L	Roller arm, LH Version A	1
	SA4100	Roller arm, LH Version B	1
2b	DL8008R	Roller arm, RH Version A	1
	SA4101	Roller arm, RH Version B	1
3	SA4051	Bearing special *(NOTE: THIS IS NOT A STANDARD 6006 2RS BEARING)	8
4	SRI-55	Snap ring, internal M55	4
5	DL10012B	Roller dust cap	2
6	DL11013	U-bolt M10 - 1.5 x 140	2
7	FW10	Flat washer M10	6
8	LW10	Lock washer M10	4
9	NM1015	Nut HH M10-1.5	4
10	BM12175110	Bolt HH M12-1.75 x 110	4
11	DL8003	Bracket roller arm	4
12	FW12	Flat washer M12	4
13	LW12	Lock washer M12	4
14	NM12175	Nut HH M12-1.75	4
15	SA4066	Roller spindle	2
16	BM061010	Bolt HH M6-1.00x10	2
17	GN0615	Grease fitting M6-1.00	2
18	SA4050	Cap, roller arm	2
19	BM101550	Bolt HH M10-1.5x50	2
20	LN1015	Nut locking M10-1.50	2
21	DL8005	Small sprocket shaft (includes flat washer, lock washer, nut, cotter pin)	2

Optional Cast Iron Roller SAYA-505

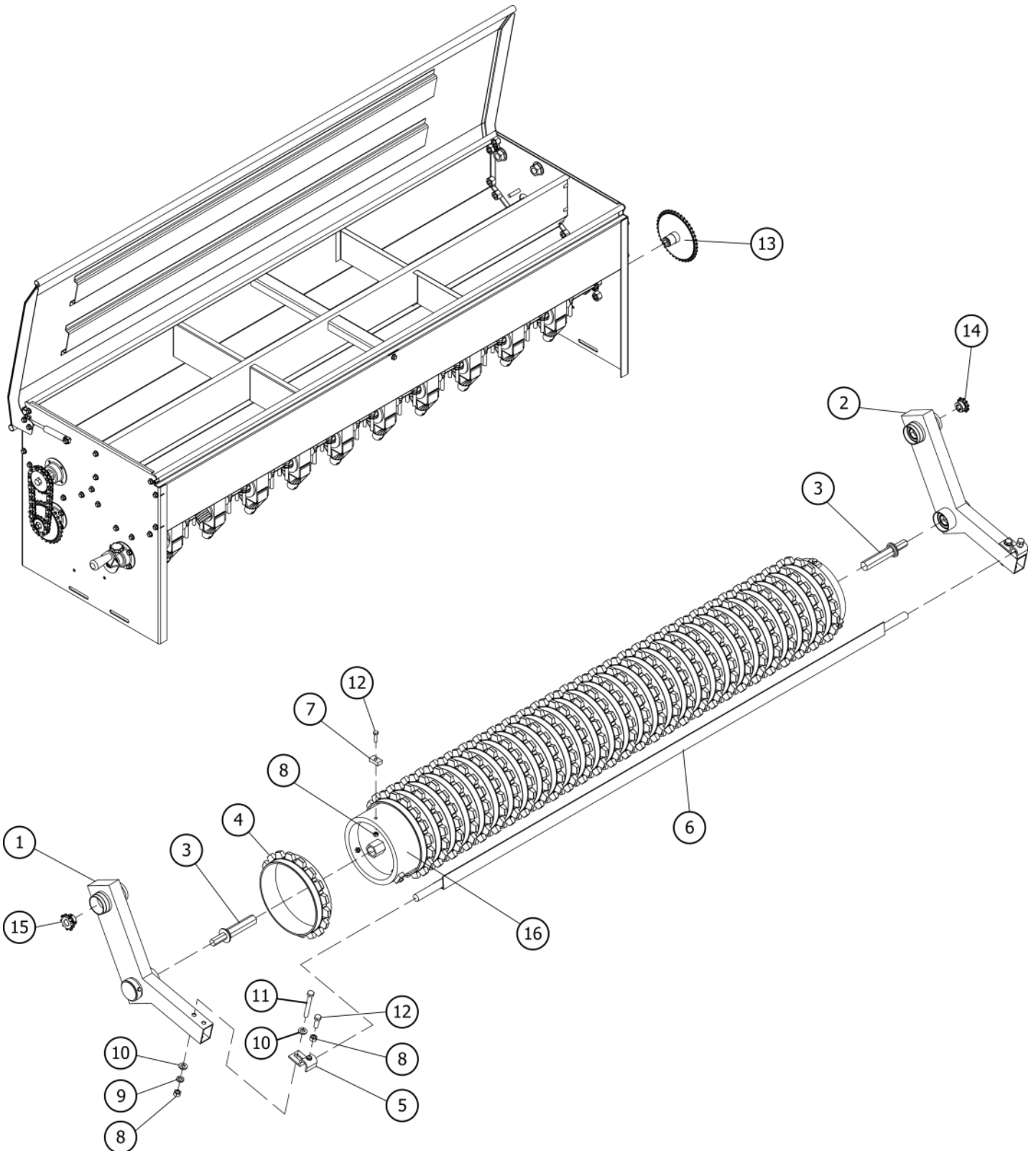

Optional Cast Iron Roller SAYA-505

Item	Part #	Description	Qty.
1	SA4102	Roller arm, LH - cast iron roller	1
2	SA4103	Roller arm, RH - cast iron roller	1
3	SA4104	Roller spindle - cast iron roller	2
4	SB100675	Cast iron cultipacker ring	-
5	SA4105	Rear support mount	2
6	SA4119	Rear support, SAYA-505 - cast iron roller	1
7	SA4107	Ring retaining tab	6
8	NM12175	Nut HH M12-1.75	10
9	LW12	Washer lock M12	2
10	FW12	Washer flat M12	4
11	BM1217590	Bolt- M12 x 175 x 90 Partial thread 8.8 - GALV	2
12	BM1217535	Bolt HH M12-1.75x35 Galv. 8.8	8
13	SA4108	Sprocket, front hopper 45T - cast iron roller	1
14	SA4112	Sprocket, drive 10T - cast iron roller	1
15	SA4114	Sprocket, drive 9T - cast iron roller	1
16	SA4120	Roller weldment, SAYA-505 - cast iron roller	1
17	ASH40	Half link, #40 roller chain (not shown)	2
18	40CHCONN	Master link, #40 roller chain (not shown)	2
19	ASH50	Half link, #50 roller chain (not shown)	2
20	50CHCONN	Master link, #50 roller chain (not shown)	2
-	SAYA-CR05	Cast Iron Roller Complete SAYA-505 (Includes all items 1-20)	-

Note: There are two additional sprockets included in the SAYA-CR07 Cast Iron Roller Complete. The Single 33T sprocket and Double 16T x 14T sprocket are not intended for use on the SAYA-505/507 machine.

See Pages 22-25 in Operator's Section for Installation Instructions.

Optional Cast Iron Roller SAYA-507

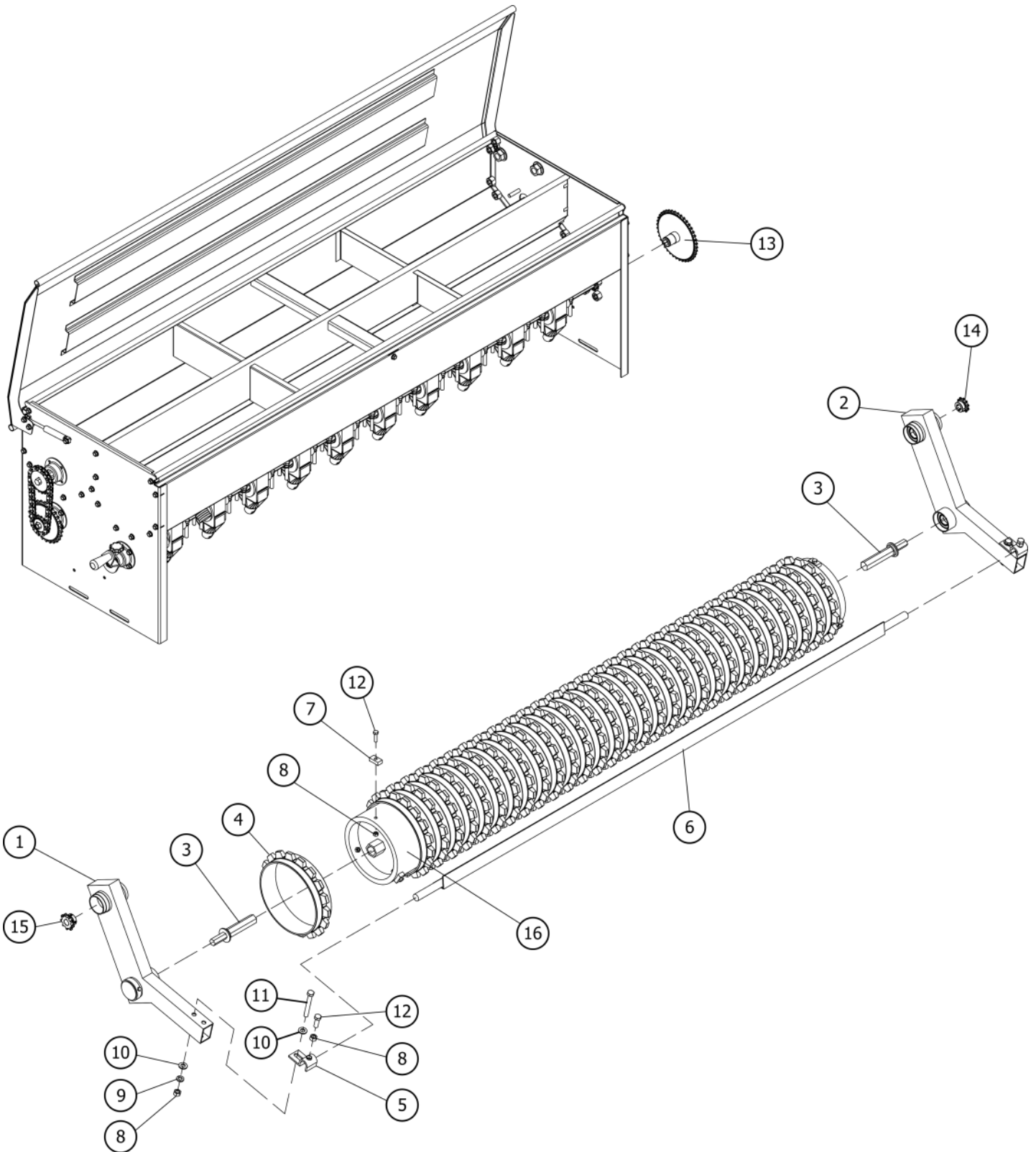

Optional Cast Iron Roller SAYA-507

Item	Part #	Description	Qty.
1	SA4102	Roller arm, LH - cast iron roller	1
2	SA4103	Roller arm, RH - cast iron roller	1
3	SA4104	Roller spindle - cast iron roller	2
4	SB100675	Cast iron cultipacker ring	30
5	SA4105	Rear support mount	2
6	SA4106	Rear support, SAYA-507/907 cast iron roller	1
7	SA4107	Ring retaining tab	6
8	NM12175	Nut HH M12-1.75	10
9	LW12	Washer lock M12	2
10	FW12	Washer flat M12	4
11	BM1217590	Bolt- M12 x 175 x 90 Partial thread 8.8 - GALV	2
12	BM1217535	Bolt HH M12-1.75x35 Galv. 8.8	8
13	SA4108	Sprocket, front hopper 45T - cast iron roller	1
14	SA4112	Sprocket, drive 10T - cast iron roller	1
15	SA4114	Sprocket, drive 9T - cast iron roller	1
16	SA4115	Roller weldment, SAYA507/907 - cast iron roller	1
17	ASH40	Half link, #40 roller chain (not shown)	2
18	40CHCONN	Master link, #40 roller chain (not shown)	2
19	ASH50	Half link, #50 roller chain (not shown)	2
20	50CHCONN	Master link, #50 roller chain (not shown)	2
-	SAYA-CR07	Cast Iron Roller Complete SAYA-507/907 (Includes all items 1-20)	-

Note: There are two additional sprockets included in the SAYA-CR07 Cast Iron Roller Complete. The Single 33T sprocket and Double 16T x 14T sprocket are not intended for use on the SAYA-505/507 machine.

See Pages 22-25 in Operator's Section for Installation Instructions.

Floorboard Assembly

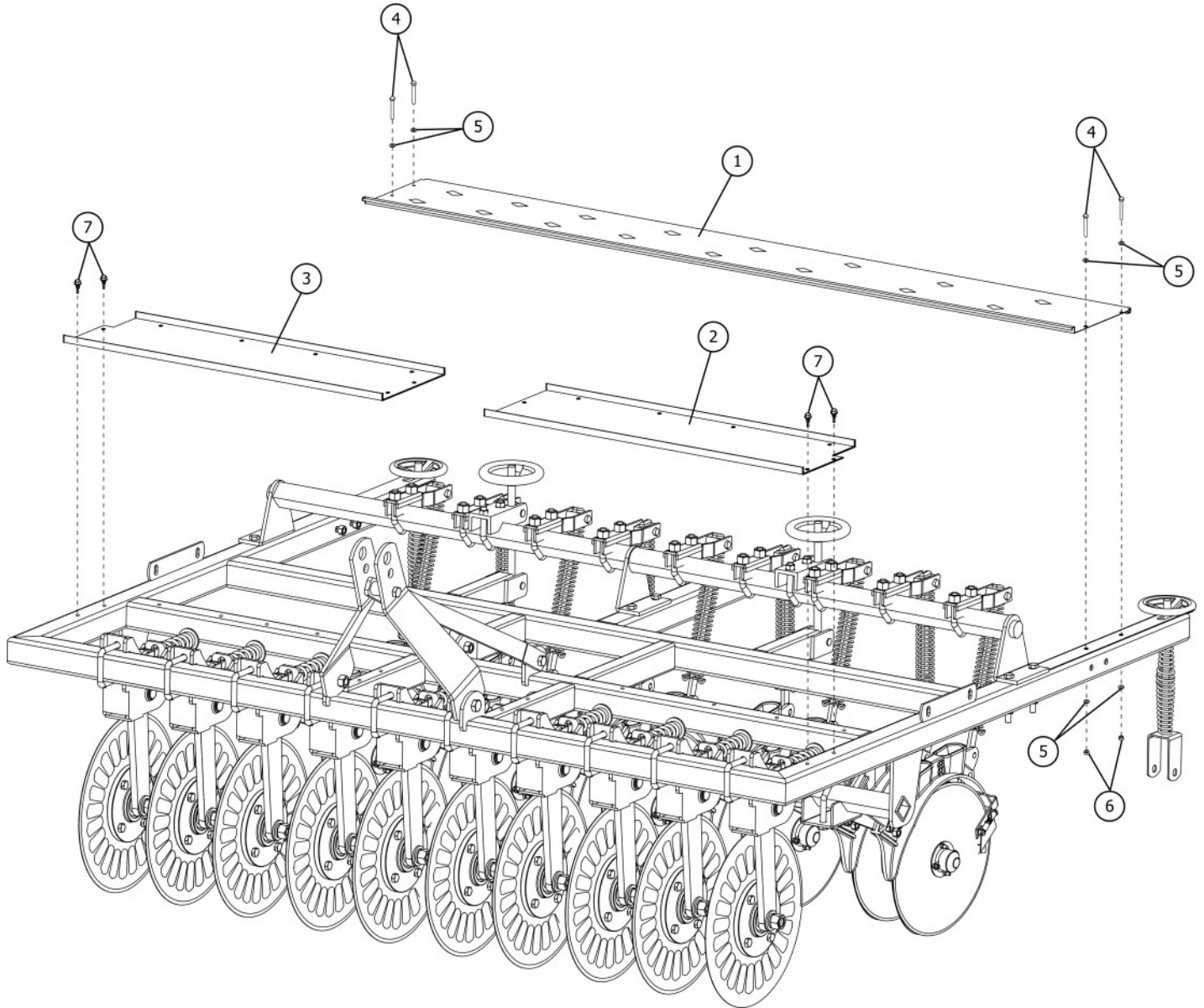

Floorboard Assembly

Item	Part #	Description	Qty.
1	SA4039	Step board, rear - SAYA505	1
	SA4042	Step board, rear - SAYA507	1
2	SA4037	Step board, LH front - SAYA505	1
	SA4040	Step board, LH front - SAYA507	1
3	SA4038	Step board, RH front - SAYA505	1
	SA4041	Step board, RH front - SAYA507	1
4	BM101580	Bolt HH M10-1.5x80	4
5	FW10	Flat washer M10	8
6	NM1015	Nut HH M10-1.5	4
7	BMST481900	Self-drilling screw M4.8x19	16

Decals

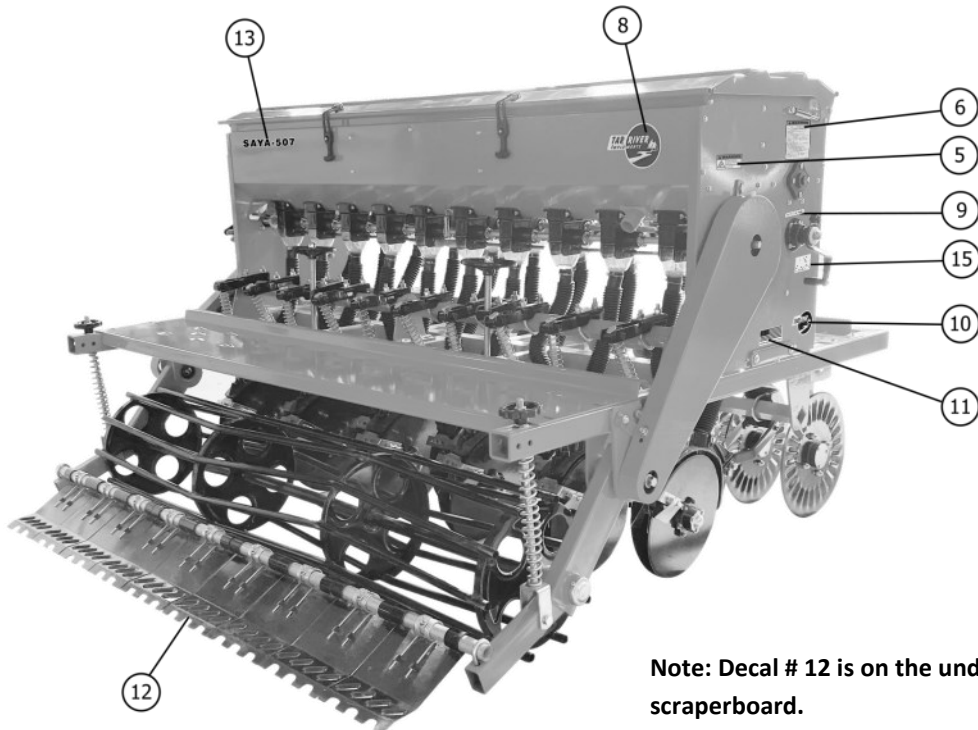
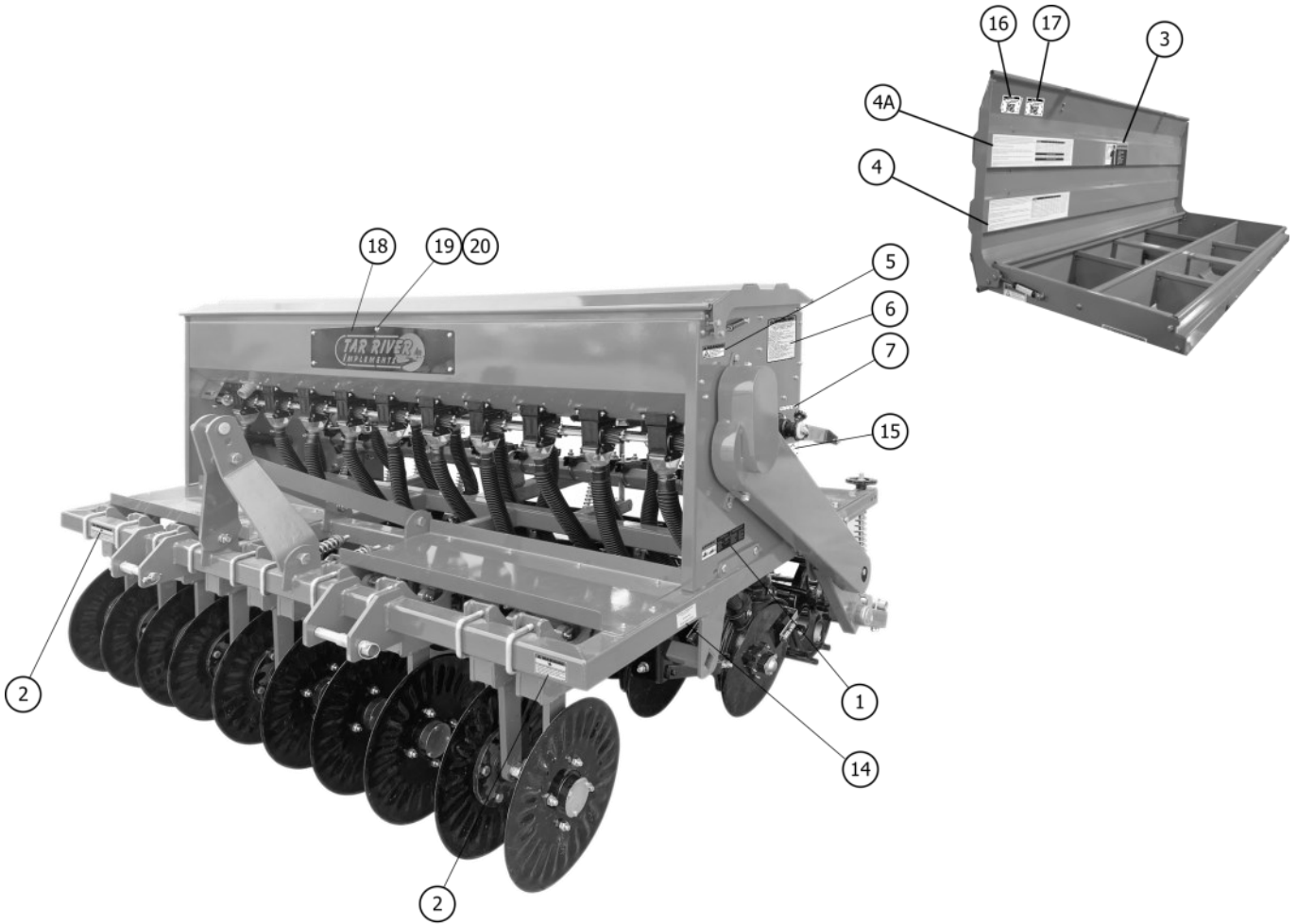

Note: Decal # 12 is on the underside of the scraperboard.

Decals

Item	Part #	Description	Qty.
1	5SBD1005	Decal Warning, "Falling off tractor"	1
2	RT-1005	Decal Warning, "To prevent serious injury or death"	2
3	D1004	Decal Warning, "Chemicals" (<i>Note: see LH inside of hopper lid</i>)	1
4	D1224F	Decal "Front Hopper SAYA-505/509" (<i>Note: see RH inside of hopper lid</i>)	1
4A	D1224R	Decal "Rear Hopper SAYA-505/509" (<i>Note: see RH inside of hopper lid</i>)	1
5	RT1004E	Decal Warning, "Do not open"	2
6	RT1004D	Decal Warning, "To prevent serious injury or death"	2
7	-	Decal Gear Ratio "12-40"	1
8	RT-1016	Decal Logo, "Tar River Implements"	1
9	-	Decal Gear Ratio "11-26"	1
10	Decal1013	Decal Logo, "Tar River Mfg"	1
11	D1309	Decal "Assembled in the USA"	1
12	D1305	Decal Attention, "Scraperboard assembly"	1
13	SAYA505	Decal Model #, SAYA-505	1
	SAYA507	Decal Model #, SAYA-507	1
14	-	Decal Serial Tag	1
15	D1316	Decal Adjustment Handle	2
16	D1328	Decal QR Code SAYA-505_507 No-Till Drill Manual	1
17	D1329	Decal QR Code SAYA Seed Calibration	1
18	D1340S	Small metal laser cut "Tar River Implements 5.50" x 23.50" (SAYA-505)	1
	D1340L	Large metal laser cut "Tar River Implements 5.50" x 30.12" (SAYA-507)	1
19	BM061012	Bolt HH06-1.0x12	5
20	FNM0610	Flange nut HH M06-1.0	5

Decals

WARNING

Falling off tractor can result in serious injury or death.

- Tractor must be equipped with ROPS (or ROPS CAB) and seat belt. Keep foldable ROPS systems in locked up position at all times.
- Buckle up! Keep seat belt securely fastened.
- Allow no riders.

To avoid serious injury or death, do not go underneath implement.

- Never go underneath raised equipment which can drop from equipment or tractor 3-point hitch, hydraulic leak down, hydraulic system failures, movement of control levers, or mechanical linkage failures. Service work does not require going underneath implement. Read manual instructions.

1 - 5SBD1005 - Qty. 1

WARNING

TO PREVENT SERIOUS INJURY OR DEATH

- Keep hands and body out of hitch area when attaching mower to tractor.
- Keep body clear of crush point between tractor and mower.

2 - RT-1005 - Qty. 2

WARNING

Chemicals may cause eye, skin, or breathing problems. Wear face mask, gloves and goggles. Read and follow safety instructions on the chemical supplier's label.

3 - 5SBD1004 - Qty. 1

4 - D1224F - Qty. 1

The most accurate way to set application rates is to drive a predetermined distance and physically catch the seeds dispensed. To do this, remove at least one drop hose and tie a plastic bag onto bottom of seed cup. Travel a determined distance and then weigh the seeds in the bag. Multiply the amount collected by the number of cups on your machine. Refer to the following example to properly calibrate your machine.

To determine area covered calculate the following:
 Disc spacing x number of discs (convert to ft.) x distance traveled divided by the sq. ft. in an acre.

Example: 10 discs with a 7.5" spacing = 75" (6.25 ft.) x 100 ft. traveled = 625 sq. ft. covered.
 625/43,560 sq. ft. in acre = .0143 (1.43% of acre covered.)

If you collect 1 oz. of seed from a single seed cup on the #3 setting after driving 100 ft. (1.43% of an acre), you are putting out 43.70 lbs. per acre.

1 oz. (amount collected) x 10 seed cups = 10 oz. total output by machine. Distance traveled = 100 ft. (1.43% of acre).

1 oz./16 oz (16 oz in 1 lb.) = .0625 / .0143 = 4.37 x 10 disc = 43.70 lbs. per acre

The most accurate way to set application rates is to drive a predetermined distance and physically catch the seeds dispensed. To do this, remove at least one drop hose and tie a plastic bag onto bottom of seed cup. Travel a determined distance and then weigh the seeds in the bag. Multiply the amount collected by the number of cups on your machine. Refer to the following example to properly calibrate your machine.

To determine area covered calculate the following:
 Disc spacing x number of discs (convert to ft.) x distance traveled divided by the sq. ft. in an acre.

Example: 10 discs with a 7.5" spacing = 75" (6.25 ft.) x 100 ft. traveled = 625 sq. ft. covered.
 625/43,560 sq. ft. in acre = .0143 (1.43% of acre covered.)

If you collect 1 oz. of seed from a single seed cup on the #3 setting after driving 100 ft. (1.43% of an acre), you are putting out 43.70 lbs. per acre.

1 oz. (amount collected) x 10 seed cups = 10 oz. total output by machine. Distance traveled = 100 ft. (1.43% of acre).

1 oz./16 oz (16 oz in 1 lb.) = .0625 / .0143 = 4.37 x 10 disc = 43.70 lbs. per acre

SAYA Front Hopper		1/2	1	2	3	4	5
Cup Setting							
Chufa				40	50		
Oats				65	90	125	
Wheat				60	90	120	
Lawn Mixtures					100	130	
Fescue					114	138	
Rye			72				
Pelletized Lima		50					
Shut off every other seed cup							
Sunflower 15" row				22	32		
Soybeans 15" row			50				
Shut off every 2 other seed cups							
Corn 22.5" row				20	35		
Approximate Pounds Per Acre							
25.5 rotations of the drive roller = 100 Feet							

NOTE: The tables and rate charts are guidelines only! They are designed to be an aid as a starting point. You must do your own calibration as many factors cause rates to change. Variations in seed/granular size, density, moisture, seed treatment, and the amount of machine overlap will affect the final application rate.

D1224F

SAYA Rear Hopper		1/2	1	2	3	4	5
Cup Setting							
Clover/Brassica/Rape		6					
Sorghum/Millet			15		30		
Alfalfa				20			
Buckwheat					50		
Timothy Grass		11.5 x 10	15				
Kentucky Blue Grass				30	40		
Radish		10					
Turnips		11					
Rye		7					
Chicory		5					
Alfalfa/Chicory (Food Plot Mix)		10.5					
Approximate Pounds Per Acre							
25.5 rotations of the drive roller = 100 Feet							

NOTE: The tables and rate charts are guidelines only! They are designed to be an aid as a starting point. You must do your own calibration as many factors cause rates to change. Variations in seed/granular size, density, moisture, seed treatment, and the amount of machine overlap will affect the final application rate.

D1224R

4A - D1224R - Qty. 1

5- RT1004E - Qty. 2

WARNING

DO NOT OPEN OR REMOVE SAFETY SHIELD WHEN MACHINE IS OPERATING.

12-40 Gear Ratio

7- Qty. 1

WARNING

To prevent serious injury or death: si no lee ingles, pida ayuda a alguien que si lo lee para que le traduzca las medidas de seguridad

- Read and understand Operator's Manual before using. Review annually.
- Do not permit riders on the tractor including children.
- Do not allow children to operate unit.
- Operate only with guards installed and in good working condition.
- Keep away from moving parts.
- Operate only with tractor equipped with ROPS and seatbelt.
- Use extra care with operating on rough terrain or when rocks or debris are present.
- Do not operate in a raised position.
- Stop engine, lower unit, set brake and wait for all moving parts to stop before dismounting.
- Support filler securely before working beneath it.
- Transport with clean reflectors, SMV and working lights as required by Federal, State and local laws.
- Keep yourself, others and clothing away from rotating PTO.
- Operate only at a safe distance from bystanders.
- Do not stand between tractor and unit.
- Be careful on uneven terrain. Decrease speed when turning.
- Locate underground utility lines before operating unit.
- Do not exceed a safe transport speed.

RT-1004D

6 - RT1004D - Qty. 2



8 - RT-1016 - Qty.

10 - D1013 Qty. 1

11-26 Gear Ratio

9 - Qty. 1



ASSEMBLED IN THE USA

11 - D-1309 Qty. 1

ATTENTION

SCRAPERBOARD ASSEMBLY MUST BE TURNED DOWN BEFORE USE TO PREVENT DAMAGE

D-1305

12 - D1305 - Qty. 1

SAYA-505

SAYA-507

13 - Qty. 1

Tar River Implements
www.TARRIVERMFG.COM

SAYA-xxx
Serial # xxxxx
Made in China

14 - Qty. 1

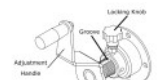

Important!

- When tightening the Locking Knob, make sure it is seated in the groove on the Adjustment Handle.
- Do not tighten the Locking Knob on the threaded portion of the Adjustment Handle!

15 - Qty. 2

Decals



16 - D1328 - Qty. 1



17 - D1329 - Qty. 1



18 - D1340L - Qty. 1

Warranty

LIMITED WARRANTY

Belco Resources Equipment warrants to the original purchaser of any new piece of machinery from Belco Resources Equipment, purchased from an authorized Belco Resources Equipment dealer, that the equipment be free from defects in material and workmanship for a period of one (1) year for non-commercial, state, and municipalities' use, ninety (90) days for commercial use from date of retail sale. Warranty for rental purposes is thirty (30) days. The obligation of Belco Resources Equipment to the purchaser under this warranty is limited to the repair or replacement of defective parts.

Replacement or repair parts installed in the equipment covered by this limited warranty are warranted for ninety (90) days from the date of purchase of such part or to the expiration of the applicable new equipment warranty period, whichever occurs later. Warranted parts shall be provided at no cost to the user at an authorized Belco Resources Equipment dealer during regular working hours. Belco Resources Equipment reserves the right to inspect any equipment or parts, which are claimed to have been defective in material or workmanship.

This limited warranty does not apply to and excludes wear items such as shear pins, tires, tubes knives, blades or other wear items. Oil or grease is not covered by this warranty.

All obligations of Belco Resources Equipment under this limited warranty shall be terminated if:

Proper service is not performed on the machine.

The machine is modified or altered in any way.

The machine is being used or has been used for purposes other than those for which the machine was intended.

DISCLAIMER OF IMPLIED WARRANTIES & CONSEQUENTIAL DAMAGES

Belco Resources Equipment obligation under this limited warranty, to the extent allowed by law, is in lieu of all warranties, implied or expressed, including implied warranties of merchantability and fitness for a particular purpose and any liability for incidental and consequential damages with respect to the sale or use of the items warranted. Such incidental and consequential damages shall include but not be limited to: transportation charges other than normal freight charges; cost of installation other than cost approved by Belco Resources Equipment; duty; taxes; charges for normal service or adjustment; loss of crops or any other loss of income; rental of substitute equipment, expenses due to loss, damage, detention or delay in the delivery.

REGISTRATION

The online Warranty Registration must be completed in order to qualify for coverage on this Limited Warranty. Visit br-equipment.com, click on "Warranty Registration" and completely fill out the form to register the new piece of equipment.

Page left blank intentionally

Page left blank intentionally



401 Jeffreys Road
Rocky Mount, NC 27804
www.tarrivermfg.com

Tel: 252-822-7140
Fax: 252-787-5855
Sales@tarrivermfg.com

Page left blank intentionally