

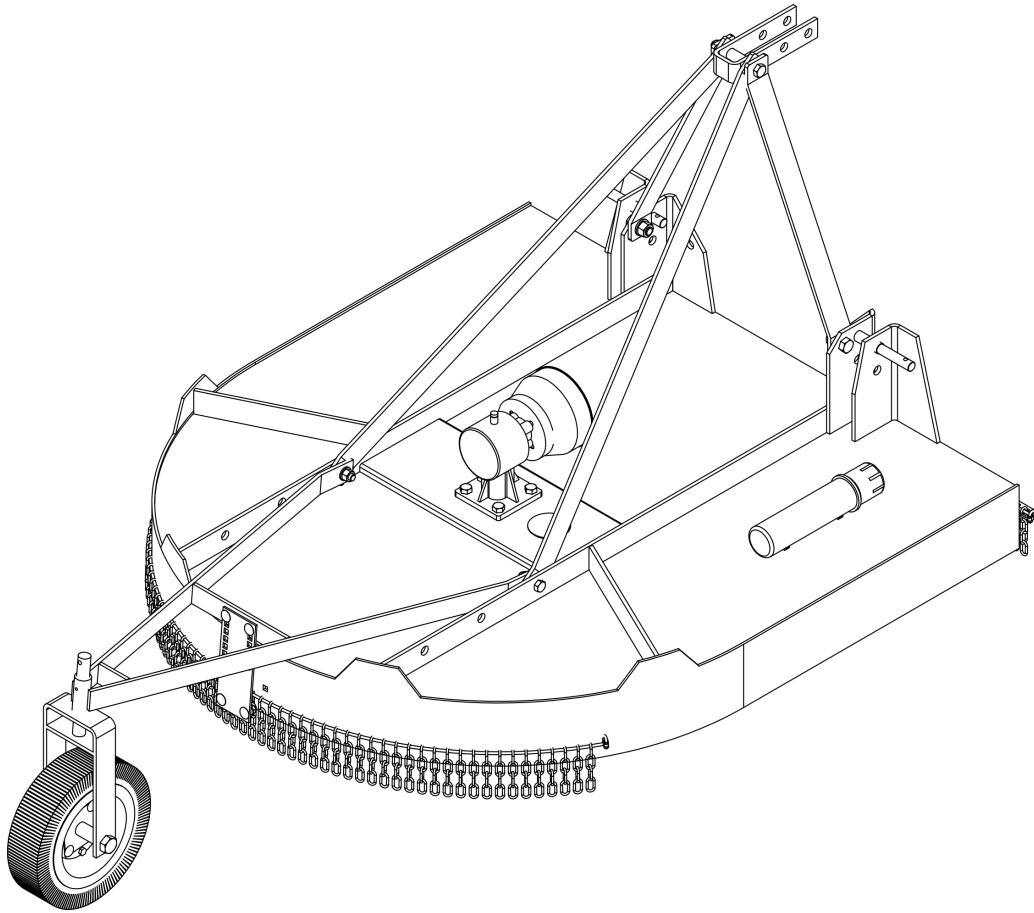

Round Back Rotary Cutter ERC Series



Operator's Manual

Page left blank intentionally

TO THE DEALER:

Assembly and proper installation of this product is the responsibility of the Tar River dealer. Read manual instructions and safety rules. Make sure all items on the Dealer's Pre-Delivery and Delivery Check Lists in the Owner's/Operator's Manual are completed before releasing equipment to the owner.

TO THE OWNER:

Read this manual before operating your Tar River equipment. The information presented will prepare you to do a better and safer job. Keep this manual handy for ready reference. Require all operators to read this manual carefully and become acquainted with all the adjustment and operating procedures before attempting to operate. Replacement manuals can be obtained from your selling dealer. The equipment you have purchased has been carefully engineered and manufactured to provide dependable and satisfactory use. Like all mechanical products, it will require cleaning and upkeep. Lubricate the unit as specified. Observe all safety information in this manual and safety decals on the equipment. For service, your authorized Tar River dealer has trained mechanics, genuine Tar River service parts, and the necessary tools and equipment to handle all your needs. Use only genuine Tar River service parts. Substitute parts will void the warranty and may not meet standards required for safe and satisfactory operation.

Record your implement model and serial number in the space provide below. Your dealer will need this information to give you prompt, efficient service.

Model Number: _____

Serial Number: _____

Date Purchased: _____

Table of Contents

Introduction	5
Technical Specifications	5
Safety	6
Safety Signal Words	6
General Safety Guidelines	7
Safety Decal Care	7
Before Operation	8
During Operation	9
Highway And Transport Operations	10-11
Assembly	12
Attaching to tractor.....	13
Attaching PTO Shaft.....	14
Adjustments.....	15-16
Maintenance/Service.....	17-19
Torque Specifications	20
Parts Breakdown	21-29
Warranty	30

Introduction

Thank you for purchasing your ERC Round Back Rotary Cutter. The ERC comes standard with front and rear chains and designed for 20-55 HP tractors. The ERC gearbox has a 5 year warranty while the rest of the machine is 1 year. A shear pin or slip-clutch PTO is available for the ERC. The rotary cutter has a capacity of 1-1/2", a pan-type stump jumper and available in working widths of 4', 5' and 6'.

Technical Specifications

	ERC-R4	ERC-R5	ERC-R6
Weight	494 lbs.	586 lbs.	714 lbs.
Req. HP	Minimum 20 HP	Minimum 25 HP	Minimum 35 HP
Working width	48"	60"	72"
Cat. hitch	1	1	1
PTO Protection	Shear-Pin	Shear-Pin	Shear-Pin

Important Safety Information

Safety

It is important that you read the entire manual and to become familiar with this product before you begin using it. This product is designed for certain applications only. The manufacturer cannot be responsible for issues arising from modification. We strongly recommend this product not be modified and /or used for any application other than that for which it is designed. If you have any questions relative to a particular application, DO NOT use the product until you have first contacted us to determine if it can or should be performed on the product.

Read and understand this manual and all safety signs before operating and maintaining . Review the safety instructions and precautions annually.

Safety Signal Words

TAKE NOTE! This safety alert symbol found though out this manual is used to call you attention to instructions involving you personal safety and the safety of others. Failure to follow these instructions can result in injury or death.



**This symbol means:
Attention!
Become alert!
Your safety is involved!**

Note the use of the signal words, DANGER, WARNING and CAUTION with the safety messages. The appropriate signal word for each has been selected using the following guidelines:



DANGER: Indicates an imminently hazardous situation that, if not avoided, will result in death or serious injury. This signal word is to be limited to the most extreme situations typically for machine components which, for functional purposes, cannot be guarded.



WARNING: Indicates a potentially hazardous situation that, if not avoided, could result in death or serious injury, and includes hazards that are exposed when guards are removed. It may also be used to alert against unsafe practices.



CAUTION: Indicates a potentially hazardous situation that, if not avoided, may result in minor or moderate injury. It may also be used to alert against unsafe practices.

Important Safety Information

General Safety Guidelines

Safety of the operator is one of the main concerns in designing and developing a new piece of equipment. Designers and manufacturers build in as many safety features as possible. However, every year many accidents occur which could have been avoided by a few seconds of thought and a more careful approach to handling equipment. You, the operator, can avoid many accidents by observing the following precautions in this section. To avoid personal injury, study the following precautions and insist those working with you, or for you, follow them.

Replace any DANGER, WARNING, CAUTION or instruction safety decal that is not readable or is missing. Location of such decals are indicated in this manual. Do not attempt to operate this equipment under the influence of drugs or alcohol.

Review the safety instructions with all users annually.

This equipment is dangerous to children and persons unfamiliar with its operation. The operator should be a responsible adult familiar with farm machinery and trained in this equipment's operations. **Do not allow persons to operate or assemble this unit until they have read this manual and have developed a thorough understanding of the safety precautions and of how it works.**

To prevent injury of death, use a tractor equipped with a Roll Over Protection System (ROPS). Do not paint over, remove or deface any signs or warning decals on your equipment. Observe all safety signs and practice the instructions on them.

Never exceed the limits of a piece of machinery. If its ability to do a job, or to do so safely, is in question - **Don't try it!**



Safety Decal Care

- Keep safety signs clean and legible at all times.
- Replace safety signs that are missing or have become illegible.
- Replaced parts that displayed a safety sign should also display the current safety sign
- Safety signs are available from your Distributor or Dealer Parts Department or the factory.

Important Safety Information

How to install Safety Signs:

- Be sure that the installation area is clean and dry.
- Decide on the exact position before you remove the backing paper.
- Remove the smallest portion of the split backing paper.
- Align the decal over the specified area and carefully press the small portion with the exposed sticky backing in place.
- Slowly peel back the remaining paper and carefully smooth the remaining portion of the decal in place.
- Small air pockets can be pierced with a pin and smoothed out using the piece of decal backing paper.



Before Operation

- Carefully study and understand this manual.
- Do not wear loose-fitting clothing, which may catch in moving parts.
- Always wear protective clothing and substantial shoes.
- Assure that all tires are inflated evenly.
- Give the unit a visual inspection for any loose bolts, worn parts or cracked welds, and make necessary repairs. Follow the maintenance safety instructions included with this manual.
- Be sure that there are no tools lying on or in the equipment.
- Do not use the unit until you are sure that the area is clear, especially of children and animals.
- Don't hurry the learning process or take the unit for granted. Ease into it and become familiar with your new equipment.
- Practice operation of your equipment and its attachments. Completely familiarize yourself and other operators with its operation before using.
- Use a tractor equipped with a Roll Over Protection System (ROPS) and fasten your seat belt prior to starting engine.
- The manufacturer does not recommend usage of tractor with ROPS removed.
- Move tractor wheels to the widest recommended settings to increase stability.
- Securely attach to towing unit. Use a high strength, appropriately sized hitch pin with a mechanical retainer and attach safety chain.
- Do not allow anyone to stand between the tongue or hitch and the towing vehicle when backing up to the equipment.
- Do not use the unit until you are sure that the area is clear, especially of children and animals.

Important Safety Information



During Operation

- Children should not be allowed on the product.
- Clear the area of small children and bystanders before moving the feeder.
- If using a towing unit, securely attach feeder by using a hardened 3/4" pin, a metal retainer, and safety chains if required. Shift towing unit to a lower gear before going down steep downgrades, thus using the engine as a retarding force. Keep towing vehicle in gear at all times. Slow down for corners and rough terrain.
- Make sure you are in compliance with all local and state regulations regarding transporting equipment on public roads and highways. Lights and slow moving signs must be clean and visible by overtaking or oncoming traffic when feeder is transported.
- Beware of bystanders, **particularly children!** Always look around to make sure that it is safe to start the engine of the towing vehicle or move the unit. This is particularly important with higher noise levels and quiet cabs, as you may not hear people shouting.
- **NO PASSENGERS ALLOWED!** Do not carry passengers anywhere on, or in, the tractor or equipment, except as required for operation.
- Keep hands and clothing clear of moving parts.
- Do not clean, lubricate or adjust your equipment while it is moving.
- When halting operation, even periodically, set the tractor or towing vehicle brakes, disengage the PTO, shut off the engine and **remove the ignition key.**
- Be especially observant of the operating area and terrain. Watch for holes, rocks or hidden hazards. Always inspect the area prior to operation.
- **DO NOT** operate near the edge of drop-offs or banks.
- **DO NOT** operate on steep slopes as overturns may result.
- Operate up and down (not across) intermediate slopes. Avoid sudden starts and stops.

Important Safety Information



Highway and Transport Operations

- Adopt safe driving practices.
- Keep the brake pedals latched together at all times. **Never use independent braking with machine in tow as loss of control and/or upset of unit can result.**
- Always drive at a safe speed relative to local conditions and ensure that your speed is low enough for an emergency stop to be safe and secure. Keep speed at a minimum.
- Reduce speed prior to turns to avoid the risk of overturning.
- Avoid sudden uphill turns on steep slopes.
- Always keep the tractor or towing vehicle in gear to provide engine braking when going downhill. Do not coast.
- Do not drink and drive!
- Comply with state and local laws governing highway safety and movement of farm machinery on public roads.
- Use approved accessory lighting flags and necessary warning devices to protect operators of other vehicles on the highway during daylight and nighttime transport. Various safety lights and devices are available from your dealer.
- The use of flashing amber lights is acceptable in most localities. However, some localities prohibit their use. Local laws should be checked for all highway and marking requirements.
- When driving the tractor and equipment on the road or highway under 40 kph (20 mph) at night or during the day, use the amber warning lights and a slow moving vehicle (SMV) identification emblem.
- Plan your route to avoid heavy traffic.
- Be a safe and courteous driver. Always yield to oncoming traffic in all situations, including narrow bridges, intersections, etc.
- Be observant of bridge loading ratings. Do not cross bridges rated at lower than the gross weight at which you are operating.
- Watch for obstructions overhead and to the side while transporting.
- Always operate in a position to provide maximum visibility at all times. Make allowances for increased length and weight of the equipment when making turns, stopping the unit, etc.
- Pick the most level route when transporting across fields. Avoid the edges of ditches or gullies and steep hillsides.
- Be extra careful when working in inclines.

Important Safety Information



Highway and Transport Operations

- Maneuver the tractor or towing vehicle at safe speeds.
- Avoid overhead wires or other obstacles. Contact with overhead lines could cause serious injury or death.
- Avoid loose fill, rocks and holes, they can be dangerous for equipment operation or movement.
- Allow for unit length when making turns,
- Operate the towing vehicle from the operator's seat only.
- Never stand alongside of unit with engine running or attempt to start engine and/or operate machine while standing alongside of unit.
- Never leave running equipment attachments unattended.
- As a precaution, always recheck the hardware on equipment following every 100 hours of operation. Correct all problems. Follow the maintenance safety procedures.

Assembly

Three Point Hitch Assembly (Fig. 1)

1. Attach the Lift Arms to the ERC front hitch mounts with M20-2.50x45 bolts, M20 washers and M20 lock-nuts. Do not tighten hardware at this time. (See Parts Section for part numbers).
2. Insert one M16-2.0x55 bolt first thru the deck frame, the Rear Brace and lastly the Tail Wheel Arm on one side. Place a M16 flat washer and M16-2.0 lock nut on the bolt. Repeat for the other side.
3. At this time, tighten all hardware according to the proper torque values. Refer to the “**Torque Specifications**” Chart on page 20.
4. The U-bracket must swing freely between the Rear Brace and Lift Arms for the deck to float properly. It may be necessary to loosen the nut slightly to allow the Rear Brace to swing freely.

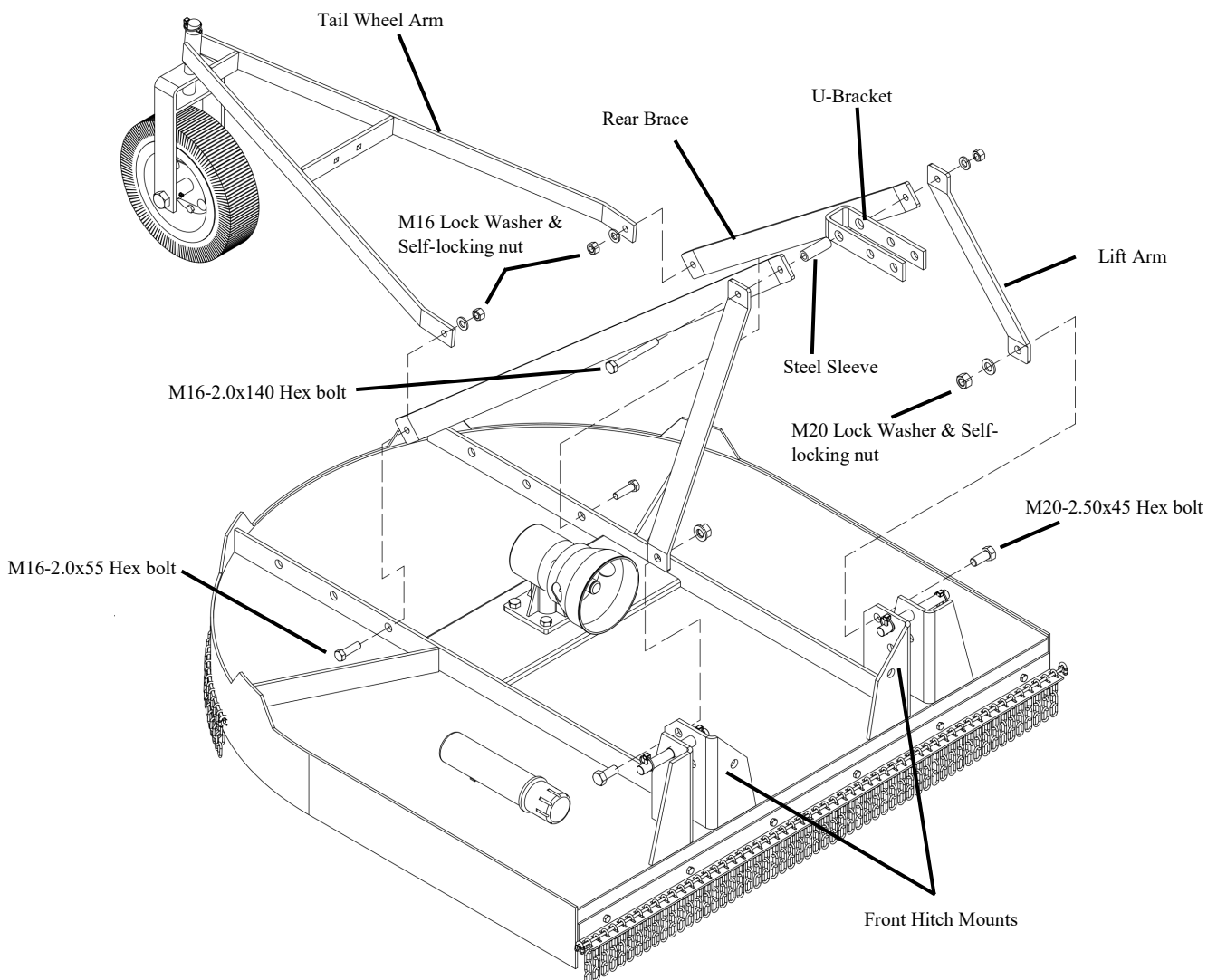

Fig. 1

Attaching to Tractor



Warning: When attaching the ERC Rotary Cutter, *Never* allow anyone to stand between the ERC Rotary Cutter and the tractor. Serious injury or death can occur!

Attaching the ERC Rotary Cutter (Fig. 2)

- Back up the tractor to the ERC Rotary Cutter, while lining up the lower tractor links to the ERC Rotary Cutter lower pins.
- Stop the engine, set the brake and remove the key from the tractor and block the tractor tires.
- Secure the tractor lower arms to the ERC Rotary Cutter lower pins with lynch pins.
- Attach the tractor top link to the ERC Rotary Cutter with the top link pin and r-clip.
- Adjust the tractor sway bars/chains to center the rotary cutter and remove excess sway.
- Adjust lower links and top link so that the ERC Rotary Cutter is level.
- Operate the tractor hydraulic controls very slowly up and down. There should be no contact between the ERC Rotary Cutter or any part of the tractor. Failure to check clearance can result in damage to the ERC Rotary Cutter, tractor (especially the tires) and possible injury to the operator. Maintain no less than 6" of clearance between the ERC Rotary Cutter, tractor and tractor tires throughout the complete range of motion.

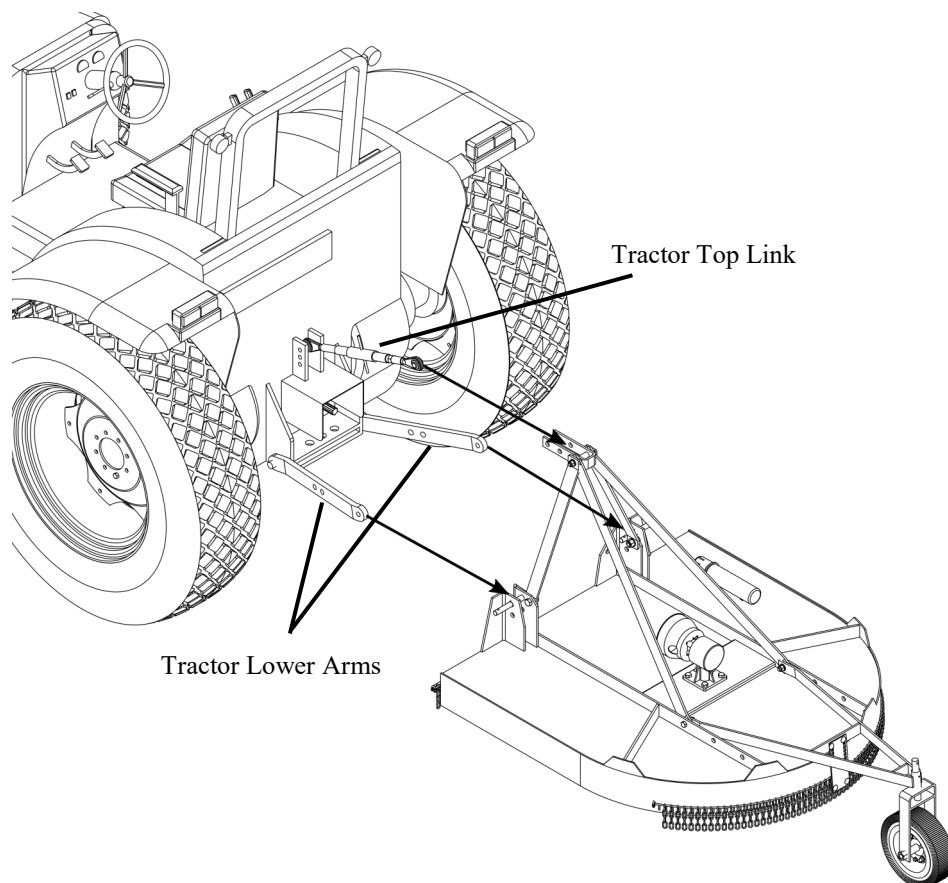

Fig. 2

Attaching PTO Shaft

Attaching the PTO shaft:

Before installing the PTO shaft make sure that the RPM rating and the direction of rotation match those of the tractor. Carefully read the PTO shaft and tractor instructions. Before operation, make sure that the guards are installed on the power take off of the tractor and PTO shaft. Make sure that they cover the PTO shaft throughout its length. Note: The PTO shaft may be too long and require shortening. See “**Shortening a PTO driveline**” below.

Press the locking pin on the PTO yoke and slide yoke on to the PTO of the tractor until the pin seats. Pull on PTO shaft to make certain it is locked in place. Repeat the procedure for the machine end. Attach the PTO cover’s safety chains to a stationary part of the tractor. Leave some slack in the chain to accommodate movement.

Shortening a PTO driveline:

1. With the machine attached to the tractor’s 3-point hitch, and the PTO shaft not installed, separate the PTO shaft. Attach the machine end to the machine and the other end to the tractor PTO input shaft.
2. Raise the machine by using the tractor’s hydraulic 3-point hitch to its maximum lift height.
3. Hold the half shafts next to each other and mark them so each end is approximately 1/2” from hitting the end of the telescopic profiles.
4. Shorten the inner and outer guard tubes equally.
5. Shorten the inner and outer profiles by the same length as the guard tubes. Using a rattail file, round off all sharp edges and burrs. Grease the telescopic profile generously before reassembling.

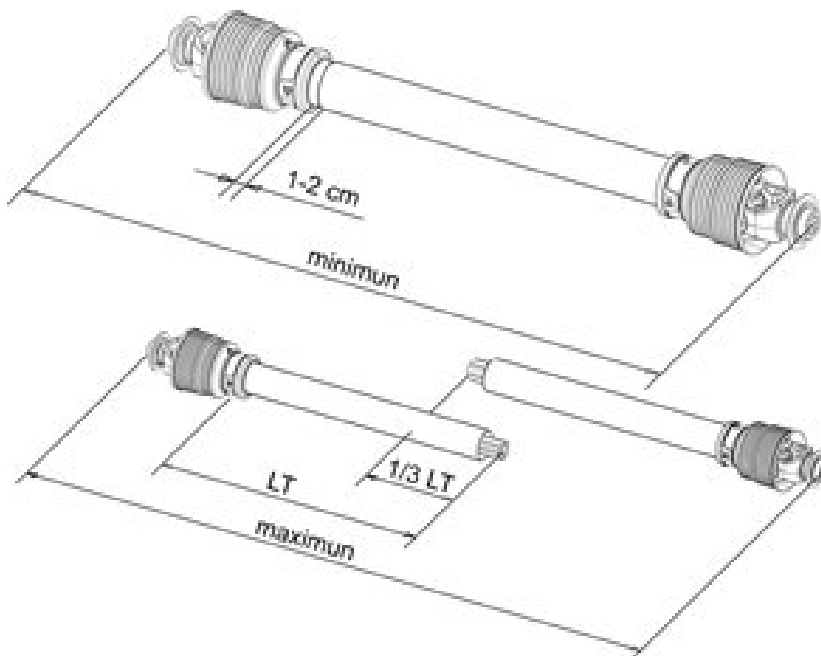

When fully extended, the tubes must overlap by at least 1/3 of the length of the pipes (LT). When retracted, the min. acceptable clearance is 1-2 cm (3/8”-3/4”)

Scan the QR code below for more detailed information on PTO installation.



Adjustments

Adjusting the Tractor Top Link - Transport Position (Fig. 3A)

When transporting the ERC Rotary Cutter, adjust the Tractor Top Link as shown in Fig. 3. making sure the U-bracket is parallel to the ground.

This position will help prevent the rotary cutter from bouncing causing damage to the implement or tractor.

The rotary cutter should not be lifted any higher than 15-20" off the ground.

Never transport the rotary cutter with the PTO engaged and blades rotating!

When transporting, do not raise the implement so high that the PTO strikes any part of the implement. This can cause damage to the PTO or implement.

Always transport the rotary cutter at a safe speed. Obey federal, state and local laws when on public highways.

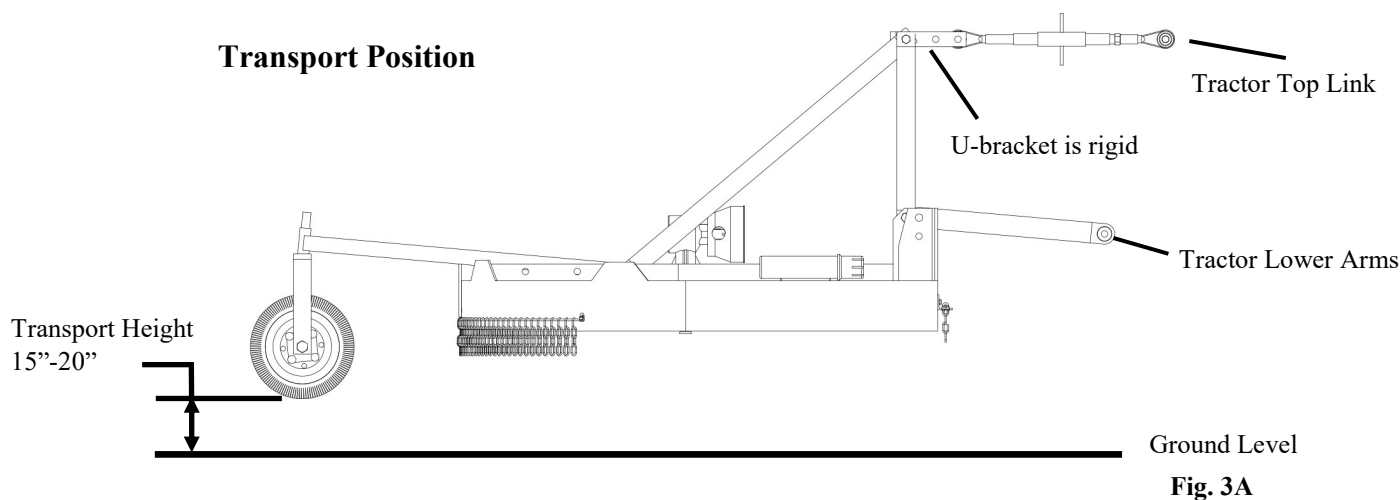

Fig. 3A

Adjusting the Tractor Top Link - Float Position (Fig. 3B)

Adjust the Tractor Top Link by twisting it to relax the U-bracket so it's pointing towards the ground similar to the illustration. The Tail Wheel should be resting on the ground.

In this position the rotary cutter will (float) follow the contour of the ground.

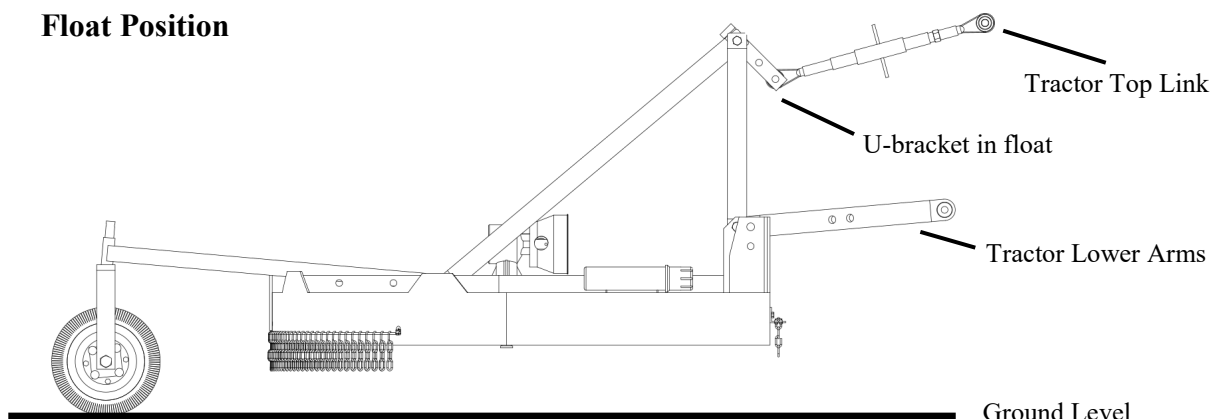

Fig. 3B

Adjustments



Warning! Before making adjustments to the ERC Rotary Cutter:

- Shut off the tractor engine, remove tractor key, set parking brake and block tractor wheels.
- Make sure the PTO, blades are not moving before making adjustments.
- Keep hands and feet away from mower blades.
- Never stand or place any body part under the deck without first blocking or securing the deck to prevent falling.
- Block the rotary cutter deck before adjusting height to prevent it from falling, causing damage to the rotary cutter, injury or possibly death.

Adjusting Cutting Height (Fig. 4)

Raise or lower the Tail Wheel Arm to the desired height by selecting a different set of holes in the Height Adjustment Plate.

It is not necessary to remove the Height Adjustment Plate from the cutter deck.

Use the tractor 3 point hitch to raise the deck, remove the upper carriage bolts, nuts and washers from the Height Adjustment Plate. Inspect the hardware removed and replace if necessary. The cutter deck is extremely heavy and should be blocked or supported to prevent possible injury or death.

Re-attach removed hardware and tighten to proper torque specifications. See “**Torque Specifications**” chart of page 19.

Caution: Adjusting the cutting height too low can cause damage to the blades and/or the rotary cutter. If the blades continuously strike the ground, raise the height of the cutter.

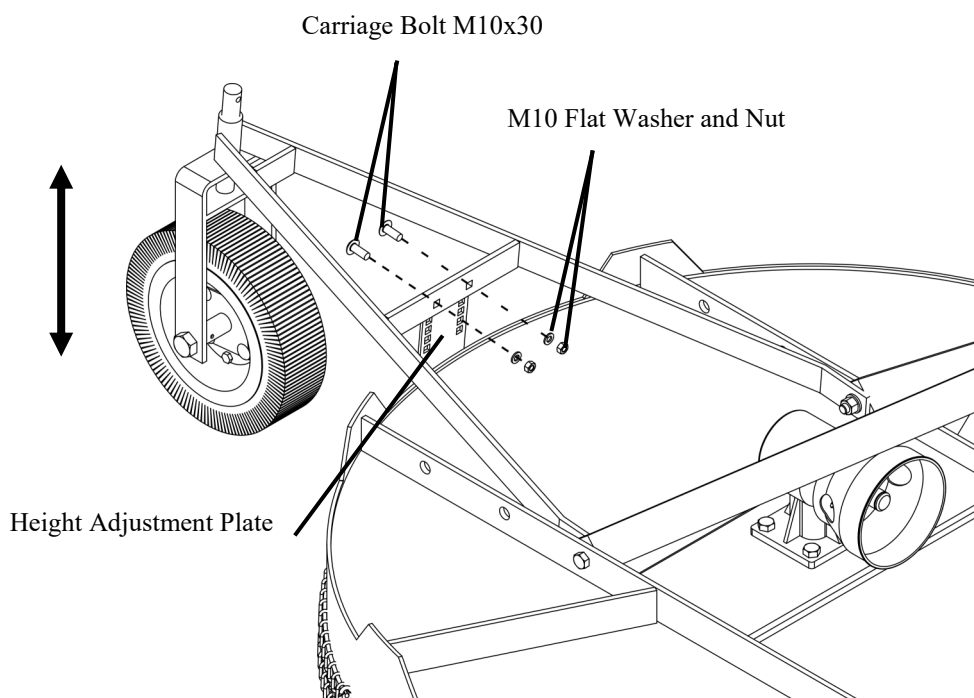

Fig. 4

Maintenance/Service



DANGER: Stop engine, lock parking brake and remove key before performing any service or maintenance.

Never rely on the tractor lift system. Place blocks or stands under the rotary cutter deck to prevent it from falling, causing serious injury or death.

Always use personal protection devices, such as glasses or gloves when performing maintenance on the rotary cutter.

- Good maintenance is your responsibility. Poor maintenance is an invitation to trouble.
- Make sure there is plenty of ventilation. Never operate the engine of the towing vehicle in a closed building. The exhaust fumes may cause asphyxiation.
- Be certain all moving parts on attachments have come to a complete stop before attempting to perform maintenance.
- Always use the proper tools or equipment for the job at hand.
- Use extreme caution when making adjustments.
- Never replace hex bolts with less than grade five bolts unless otherwise specified.
- After servicing, be sure all tools, parts and service equipment are removed.
- Where replacement parts are necessary for periodic maintenance and servicing, genuine factory replacement parts must be used to restore your equipment to original specifications. The manufacturer will not claim responsibility for use of unapproved parts and/or accessories and other damages as a result of their use.
- If equipment has been altered in any way from original design, the manufacturer does not accept any liability for injury or warranty.
- Check all the tightness of all hardware on the rotary cutter on a regular basis. Check condition of blades and stump jumper.
- Check the gear box for proper amount of oil. Grease the tail wheel arm and tail wheel as necessary.

Maintenance/Service



Warning: To avoid injury when changing blades, always wear Personal Protective Equipment, gloves, eye protection, etc.

Blade inspection/replacement (Fig. 5)

1. Remove the access cap from the gearbox mount plate, to access the blade nuts. Rotate the blades so that the blade bolt nut lines up with the access hole.
2. Block the blade to prevent it from moving. Using a pull bar, ratchet or impact wrench, remove the blade nut and blade from the implement.
3. Inspect the condition of the blades and blade hardware.
4. Replace the blades if worn, dull, damaged or distorted. A worn or damaged blade will give a less than optimal cut and can cause excessive vibration. Replace bolts if damaged or worn.
5. Install new OEM blades, OEM bolts and torque to proper torque specifications. Make sure the blades swing freely to prevent damage to the rotary cutter.
6. It is important that the blade's cutting edge faces the direction of rotation. Note that the rotary cutter blades rotate in a clockwise direction as viewed from underneath the cutter.
7. Replace the access cap and any parts or shields removed.

Important:

- Blade bolts should be checked for proper torque every 8 hours. Replace with only OEM bolts. These bolts are special made for this rotary cutter.
- Replace with OEM blades in pairs to ensure proper balance. Unbalanced blades can cause excessive vibration and possible damage to the rotary cutter.

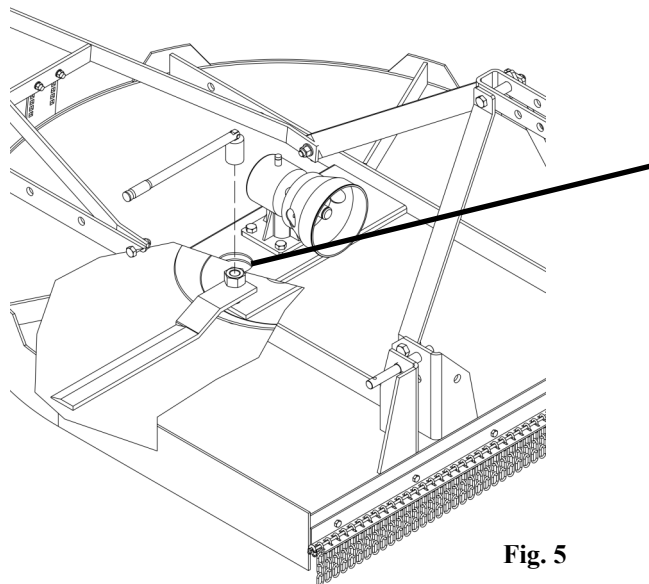

Access to blade bolt nuts. Cap removed.

Note: Some parts/shield removed for clarity. Always replace any parts/shields removed before operating the rotary cutter. Serious injury or death can occur.

Fig. 5

Maintenance/Service

Lubrication

Every 8 hours:

Grease the tail wheel yoke and the tail wheel hub, Fig. 6A.

Check the gear box oil by observing the site glass on the LH side of the gearbox. Add SAE 90W gear oil as needed, Fig. 6A.

Grease the PTO shaft and apply a light layer of grease on the inner tube, Fig. 6B.

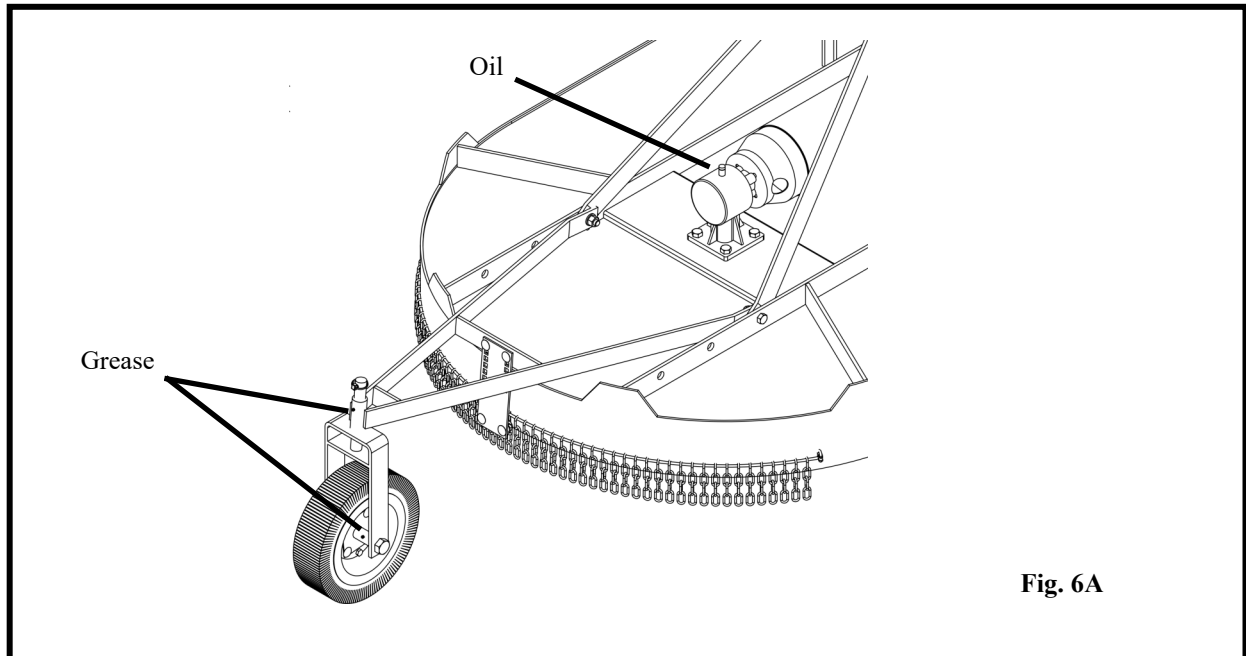

Fig. 6A

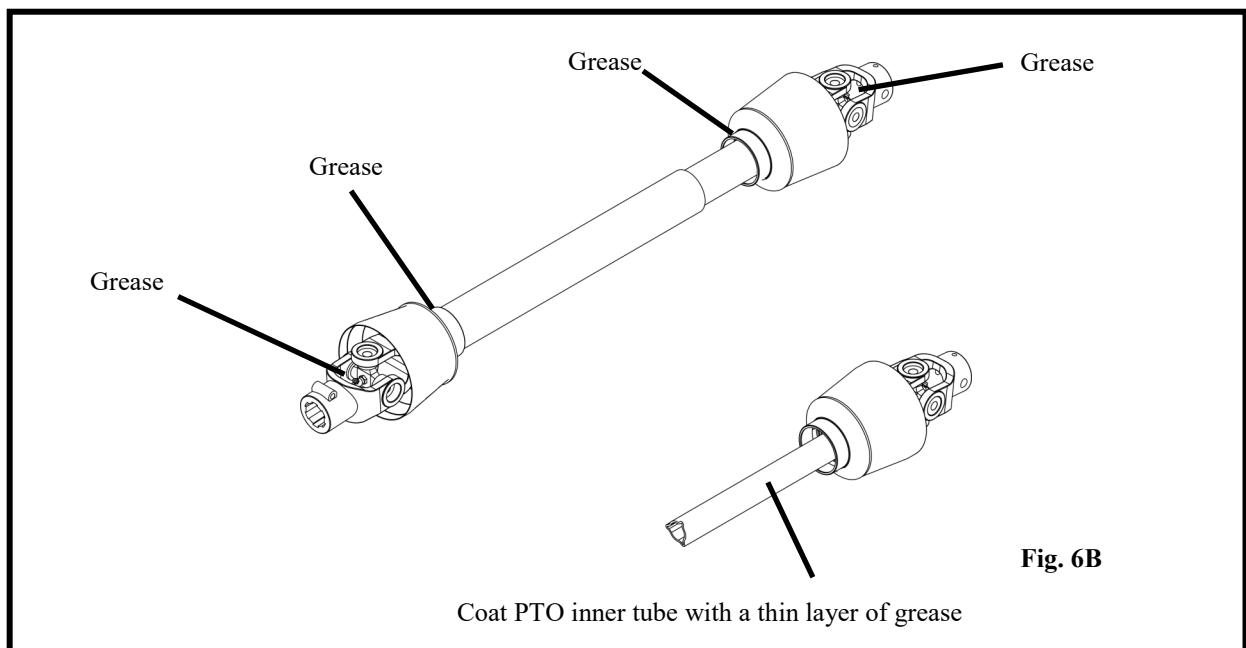

Fig. 6B

Coat PTO inner tube with a thin layer of grease

Torque Specifications

Torque Specifications for Common Bolt Sizes															
Inches		Bolt Head Identification						Metric		Bolt Head Identification					
Bolt size (inches)	Thread pitch	Grade 2		Grade 5		Grade 8		Bolt size (metric)	Thread pitch	Class 5.8		Class 8.8		Class 10.9	
		N.m	ft-lb	N.m	ft-lb	N.m	ft-lb			N.m	ft-lb	N.m	ft-lb	N.m	ft-lb
1/4"	20	7	5	11	8	16	12	M5	0.08	4	3	6	4	9	7
1/4"	28	8	6	13	10	19	14	M6	1	6	4	10	7	15	11
5/16"	18	15	11	24	17	33	25	M8	1.25	16	12	25	18	36	27
5/16"	24	17	13	26	19	37	27	M8	1	17	13	26	19	38	28
3/8"	16	27	20	42	31	59	44	M10	1.5	31	23	48	35	71	52
3/8"	24	31	23	47	35	67	49	M10	1.25	33	24	51	38	75	55
7/16"	14	43	32	67	49	95	70	M10	1	35	26	53	39	78	58
7/16"	20	48	36	75	55	106	78	M12	1.75	54	40	84	62	123	91
1/2"	13	66	48	102	75	144	106	M12	1.5	56	41	87	64	128	94
1/2"	20	75	55	115	85	163	120	M12	1.25	59	44	90	66	133	98
9/16"	12	95	70	147	109	208	154	M14	2	84	62	133	98	195	144
9/16"	18	106	79	164	121	232	171	M14	1.5	94	69	142	105	209	154
5/8"	11	132	97	203	150	287	212	M16	2	131	97	206	152	302	223
5/8"	18	149	110	230	170	325	240	M16	1.5	141	104	218	161	320	236
3/4"	10	233	172	361	266	509	376	M18	2.5	181	133	295	218	421	310
3/4"	16	261	192	403	297	569	420	M18	2	196	145	311	229	443	327
7/8"	9	226	167	582	430	822	606	M18	1.5	203	150	327	241	465	343
7/8"	14	249	184	642	473	906	668	M20	2.5	256	189	415	306	592	437
1"	8	339	250	873	644	1232	909	M20	1.5	288	212	454	335	646	476
1"	12	371	273	955	704	1348	995	M22	2.5	344	254	567	418	807	595
1-1/8"	7	480	354	1077	794	1746	1288	M22	1.5	381	281	613	452	873	644
1-1/8"	12	539	397	1208	891	1958	1445	M24	3	444	327	714	526	1017	750
1-1/4"	7	677	500	1519	1120	2463	1817	M24	2	488	360	769	567	1095	808
1-1/4"	12	750	553	1682	1241	2728	2012	M27	3	656	484	1050	774	1496	1103
1-3/8"	6	888	655	1992	1469	3230	2382	M27	2	719	530	1119	825	1594	1176
1-3/8"	12	1011	746	2268	1673	3677	2712	M30	3.5	906	668	1420	1047	2033	1499
1-1/2"	6	1179	869	2643	1949	4286	3161	M30	2	1000	738	1600	1180	2250	1659
1-1/2"	12	1326	978	2974	2194	4823	3557	M36	4	1534	1131	2482	1830	3535	2607

Notes:

This chart is an approximate estimate of torque values.

Always tighten hardware to these values unless a different torque value or tightening procedure is listed for a specific application.

Fasteners must always be replaced with the same grade as specified in the manual.

Always use the proper tool for tightening hardware: SAE for SAE hardware and Metric for Metric hardware.

Make sure that fastener threads are clean and that you properly start thread engagement.



Round Back Rotary Cutter ERC Series

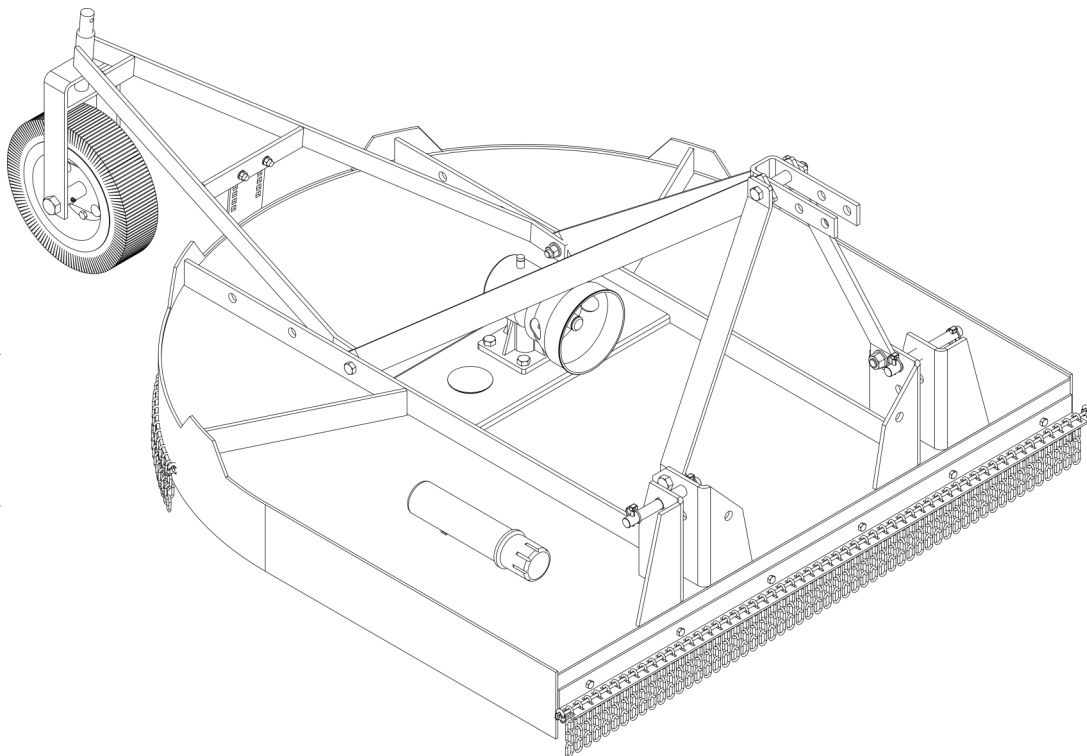

Parts Manual

ERC Rotary Cutter Frame

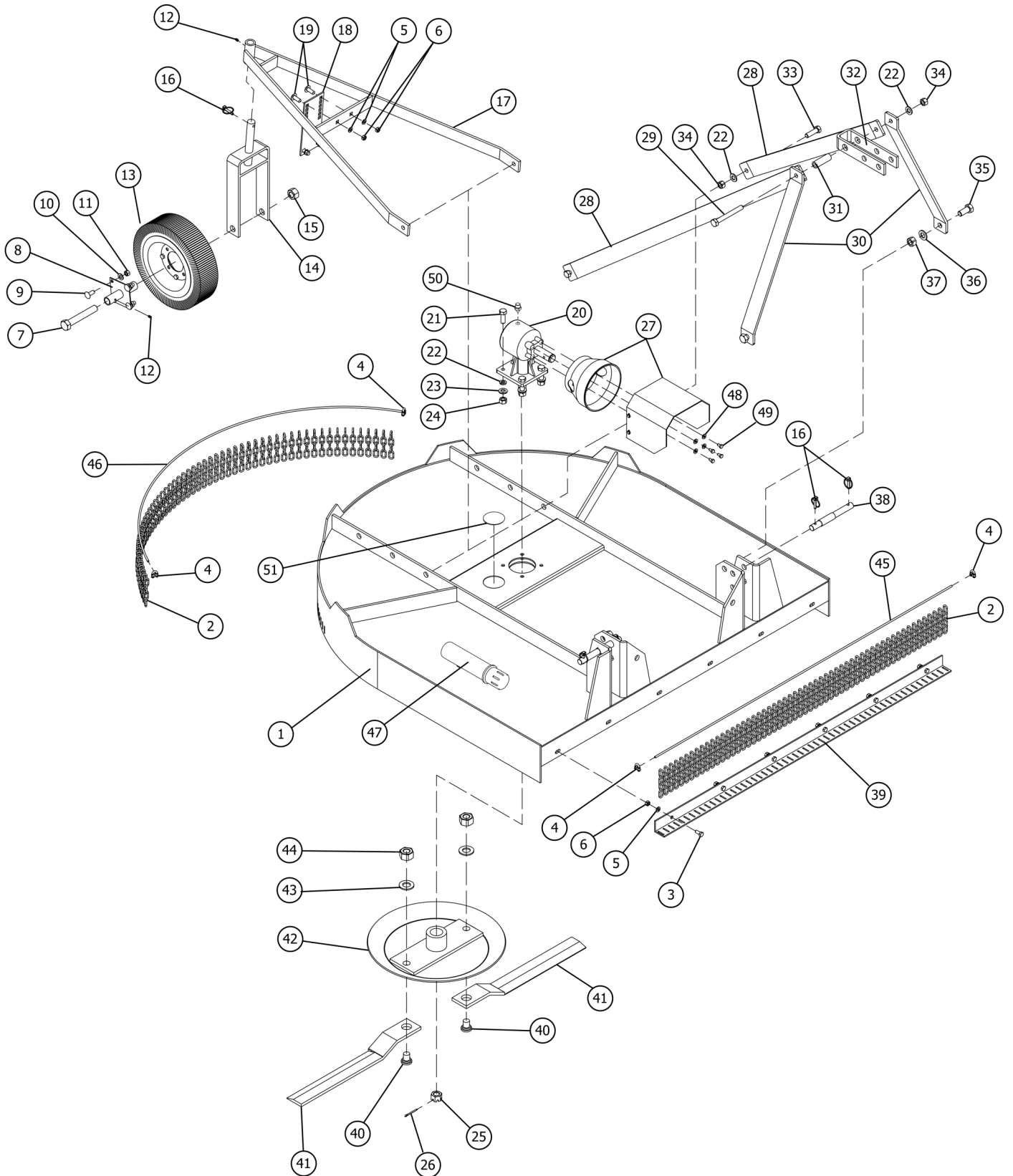

ERC Rotary Cutter Frame

Item	Part #	Description	Qty.
1	ERC670401	Main deck - 4 ft	1
	ERC670501	Main deck - 5 ft	1
	ERC670661	Main deck - 6 ft	1
2	ERC030440	Chain links - 4 ft	-
	ERC030504	Chain links -5 ft	-
	ERC030640	Chain links - 6 ft	-
3	BM101525	Bolt HH M10-1.5x25	10
4	ERC670004	Buckle	4
5	FW10	Flat washer M10	10
6	LNM1015	Nut self-locking	10
7	BM2430180	Bolt HH M24-3.0x180	1
8	ERC030037	Wheel hub	1
9	CBM1217530	Bolt carriage M12-1.75x30	4
10	FW12	Washer flat M12	4
11	LNM12175	Nut self-locking M12-1.75	4
12	GN081S	Grease nipple M08x1.0 straight	2
13	ERC030017	Tail wheel Ø390x95	1
14	ERC670014	Wheel fork	1
15	LNM2430	Nut self-locking M24-3.0	1
16	LYNPN08	Lynch pin M08	3
17	ERC670417	A-frame 4ft	1
	ERC670517	A-frame 5ft	1
	ERC670617	A-frame 6ft	1
18	ERC670018	Height adjustment bar	1
19	CBM101530	Bolt carriage M10-1.50x30	4
*20	ERC030421	Gear box (smooth input shaft) 45 hp (4ft)	1
	ERC030521	Gear box (smooth input shaft) 45 hp (5ft/6ft)	1
	ERC031521	Gear box (6 spline input shaft) 45 hp (4ft)	1
	ERC031621	Gear box (6 spline input shaft) 45 hp (5ft/6ft)	1
21	BM162045	Bolt HH M16-2.0x45	4
22	FW16	Washer flat M16	7
23	LW16	Washer lock M16	4
24	NM1620	Nut HH M16-2.0	4
25	CNM242	Nut castle M24-2.0	1
26	CP5x50	Cotter pin M5x50	1
27	ERCSHIELD	Gearbox shield (metal) - slip clutch PTO	-
	FM10060	Gearbox shield (plastic) - push pin PTO	-

***NOTE: Before ordering parts for the gearbox, SEE Notes on Page 26.**

ERC Rotary Cutter Frame

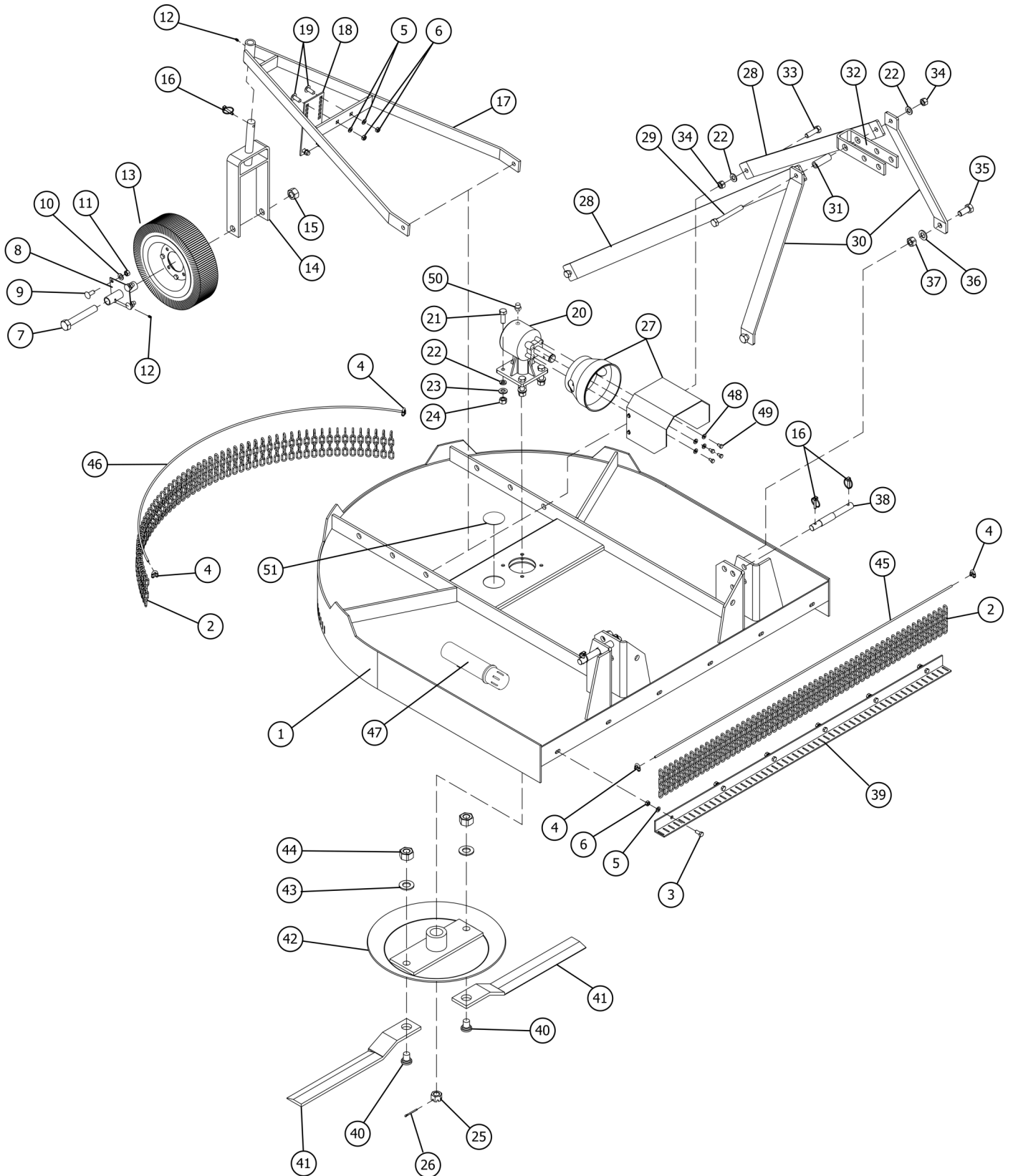

ERC Rotary Cutter Frame

Item	Part #	Description	Qty.
28	ERC670428	Rear brace (4ft)	2
	ERC670528	Rear brace (5ft)	2
	ERC670628	Rear brace (6ft)	2
29	BM1620140	Bolt HH M16-2.0x140	1
30	ERC670030	Lift arm	2
31	ERC670031	Steel sleeve	1
32	ERC670032	U-bracket	1
33	BM162055	Blot HH M16-2.0x55	2
34	LNM1620	Nut self-locking M16-2.0	3
35	BM20245	Bolt HH M20-2.50x45	2
36	LW20	Washer flat M12	2
37	LNM2025	Nut self-locking M20-2.25	2
38	ERC670038	Hitch pin	2
39	ERC670439	Front chain (4ft)	1
	ERC670539	Front chain (5ft)	1
	ERC670639	Front chain (6ft)	1
40	ERC670040	Blade bolt M27	2
41	ERC030424	Blade (4ft)	2
	ERC030524	Blade (5ft)	2
	ERC030624	Blade (6ft)	2
42	ERC670042	Blade holder	1
43	FW27	Washer flat M27	2
44	LNM2715	Nut self-locking M27-1.5	2
45	ERC670445	Front chain wire (4ft)	1
	ERC670545	Front chain wire (5ft)	1
	ERC670645	Front chain wire (6ft)	1
46	ERC670446	Rear chain wire (4ft)	1
	ERC670546	Rear chain wire (5ft)	1
	ERC670646	Rear chain wire (6ft)	1
47	MH20000	Manual holder	1
48	FW08	Washer flat M8	4
49	BM0812512	Bolt HH M08-1.25x12	4
50	OP1/4-18B	Oil breather plug - 1/4 NPTF	1
51	ERC030051	Bolt cap	1

ERC Rotary Cutter Gearbox

Note 1: There are two styles of gearboxes for the ERC Rotary Cutters. Previous models were supplied with a gearbox having a smooth input shaft, (Fig. A). Current production models are equipped with gearboxes having a splined input shaft, (Fig. B). Before ordering parts, identify your machine's gearbox by examining the shaft whether it is has smooth input shaft or splined input shaft.

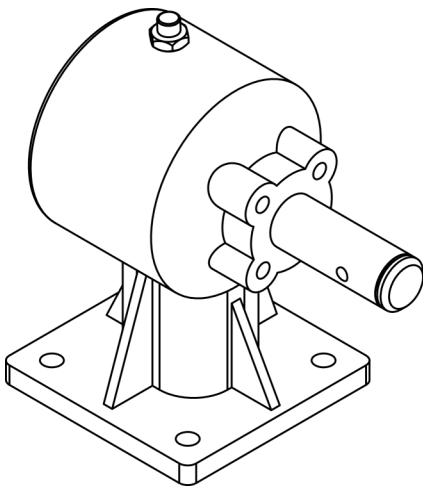

Fig. A

Gearbox with smooth shaft:
 Replace the shear bolt with PN
 BM1217585 (Class 8.8) or
 BS1/2-13x3SB (Grade 5).

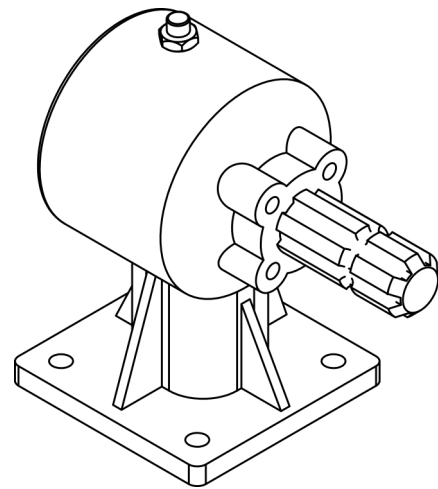
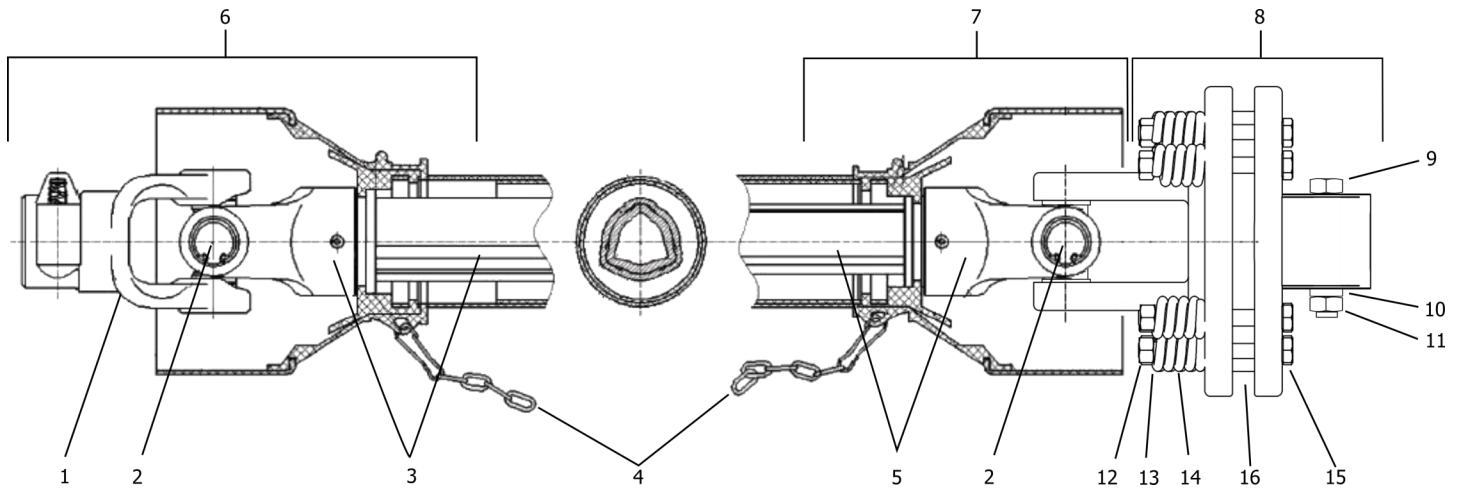

Fig. B

Gearbox with splined shaft:
 A shear bolt is not required on
 the gearbox but is for the PTO.
 Replace the PTO shear bolt with
 PN DP1081 Bolt M8x1.25x50
 8.8. with self-locking nut.

ERC Rotary Cutter PTO - Slip Clutch



Item	Part #	Description	Qty.
1	DP1075-40	PTO Yoke - Series 40	1
2	DP1076-40	Cross and Bearings - Series 40	2
3	DP1079-40	Female Yoke and Tube (tractor end) - Series 40	1
4	5SB3007	Safety chain	2
5	DP1078-40	Male Yoke and Tube (implement end) - Series 40	1
6	DP1074F-40	Complete Female End PTO Shielding (tractor end)	1
7	DP1074M-40	Complete Male End PTO Shielding (implement end)	1
8	DP1098-40	Slip clutch complete - series 40 (180 mm)	1
9	BM1217565	Bolt HH M12-1.75x65 (8.8)	2
10	LNM12175	Nut lock M12-1.75	2
11	FW12	Washer flat M12	2
12	LNM1015	Nut lock M10-1.50	8
13	FW10	Washer flat M10	8
14	1215012-30	Spring - slip clutch	8
15	BM1015100	Bolt HH 10-1.50x100 (8.8)	8
16	180-510-40	Friction disc - 142mm x 78mm x 3mm	4
-	ERC031628	PTO- Splined input shaft w/Slip Clutch 42"	1

ERC Rotary Cutter PTO - Shear Bolt

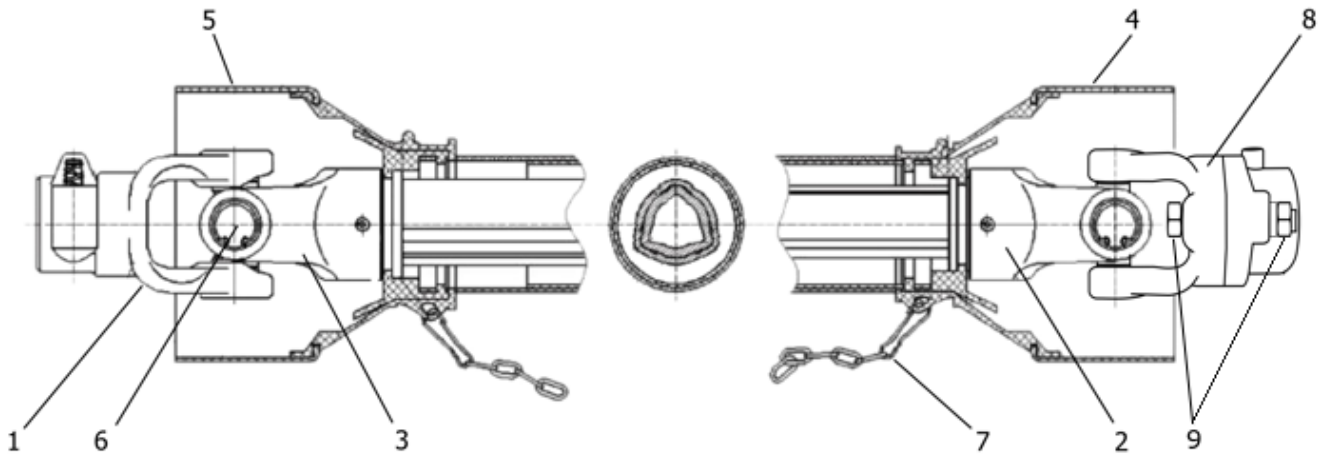

Item	Part #	Description	Qty.
1	DP1075-40	PTO Yoke - Series 40	1
2	DP1076-40	Cross and Bearings - Series 40	2
3	DP1079-40	Female Yoke and Tube (tractor end) - Series 40	1
4	5SB3007	Safety chain	2
5	DP1078-40	Male Yoke and Tube (implement end) - Series 40	1
6	DP1074F-40	Complete Female End PTO Shielding (tractor end)	1
7	DP1074M-40	Complete Male End PTO Shielding (implement end)	1
8	DP1077-40	Yoke - shear bolt type	1
9	DP1081	Bolt M8x1.25x50 8.8 with self-locking nut	1
-	ERC031628SP	PTO- Splined input shaft w/Shear Bolt 42"	1

ERC Rotary Cutter PTO - Smooth Shaft

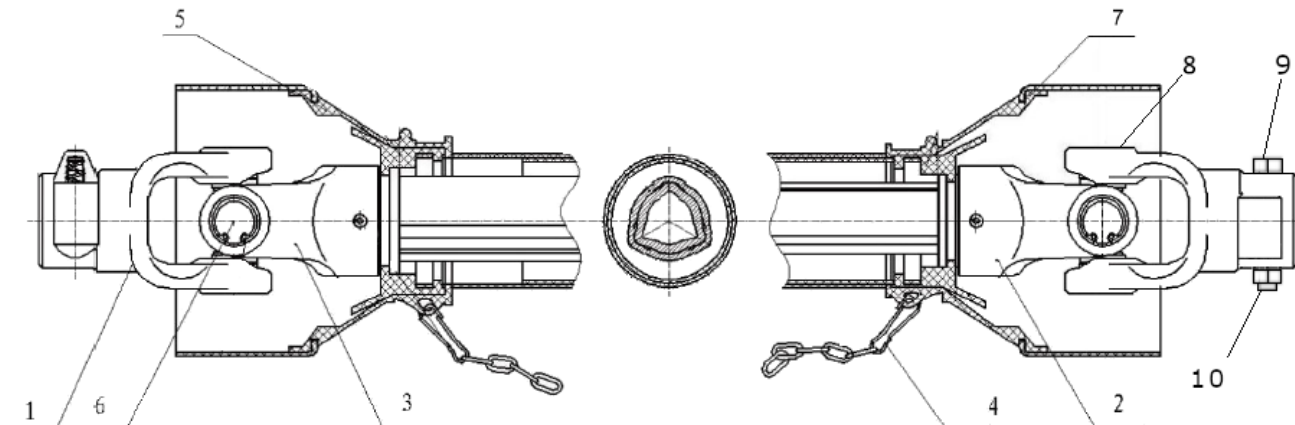

NOTE: This PTO is for Gearboxes with a smooth input shaft only!

Item	Part #	Description	Qty.
1	DP1075-40	PTO Yoke - Series 40	1
2	DP1076-40	Cross and Bearings - Series 40	2
3	DP1079-40	Female Yoke and Tube (tractor end) - Series 40	1
4	5SB3007	Safety chain	2
5	DP1078-40	Male Yoke and Tube (implement end) - Series 40	1
6	DP1074F-40	Complete Female End PTO Shielding (tractor end)	1
7	DP1074M-40	Complete Male End PTO Shielding (implement end)	1
8		Yoke - shear bolt type - smooth shaft	1
*9	M1217585	Bolt M12-1.75x85 C8.8	1
	BS1/2-13.3	Bolt 1/2-13x3 Grade 5	1
*10	LNM12175	Self locking nut M12-1.75	1
	LNS1/2-13	Self locking nut 1/2-13	1
-	ERC030628SP	PTO- Smooth input shaft w/Shear Bolt 42"	1

*NOTE: Items 9 & 10 can be substituted with metric or standard size bolt/nut depending on availability. Be sure to use metric nut with metric bolt and standard nut with standard bolt. Always use the correct hardness bolt or damage to implement and or tractor can occur.

Warranty

LIMITED WARRANTY

Belco Resources Equipment warrants to the original purchaser of any new piece of machinery from Belco Resources Equipment, purchased from an authorized Belco Resources Equipment dealer, that the equipment be free from defects in material and workmanship for a period of one (1) year for non-commercial, state, and municipalities' use, ninety (90) days for commercial use from date of retail sale. Warranty for rental purposes is thirty (30) days. The obligation of Belco Resources Equipment to the purchaser under this warranty is limited to the repair or replacement of defective parts.

Replacement or repair parts installed in the equipment covered by this limited warranty are warranted for ninety (90) days from the date of purchase of such part or to the expiration of the applicable new equipment warranty period, whichever occurs later. Warranted parts shall be provided at no cost to the user at an authorized Belco Resources Equipment dealer during regular working hours. Belco Resources Equipment reserves the right to inspect any equipment or parts, which are claimed to have been defective in material or workmanship.

This limited warranty does not apply to and excludes wear items such as shear pins, tires, tubes knives, blades or other wear items. Oil or grease is not covered by this warranty.

All obligations of Belco Resources Equipment under this limited warranty shall be terminated if:

Proper service is not performed on the machine.

The machine is modified or altered in any way.

The machine is being used or has been used for purposes other than those for which the machine was intended.

DISCLAIMER OF IMPLIED WARRANTIES & CONSEQUENTIAL DAMAGES

Belco Resources Equipment obligation under this limited warranty, to the extent allowed by law, is in lieu of all warranties, implied or expressed, including implied warranties of merchantability and fitness for a particular purpose and any liability for incidental and consequential damages with respect to the sale or use of the items warranted. Such incidental and consequential damages shall include but not be limited to: transportation charges other than normal freight charges; cost of installation other than cost approved by Belco Resources Equipment; duty; taxes; charges for normal service or adjustment; loss of crops or any other loss of income; rental of substitute equipment, expenses due to loss, damage, detention or delay in the delivery.

REGISTRATION

The online Warranty Registration must be completed in order to qualify for coverage on this Limited Warranty. Visit br-equipment.com, click on "Warranty Registration" and completely fill out the form to register the new piece of equipment.

Page left blank intentionally



401 Jeffreys Road
Rocky Mount, NC 27804
www.tarrivermfg.com

Tel: 252-822-7140
Fax: 252-787-5855
Sales@tarrivermfg.com