

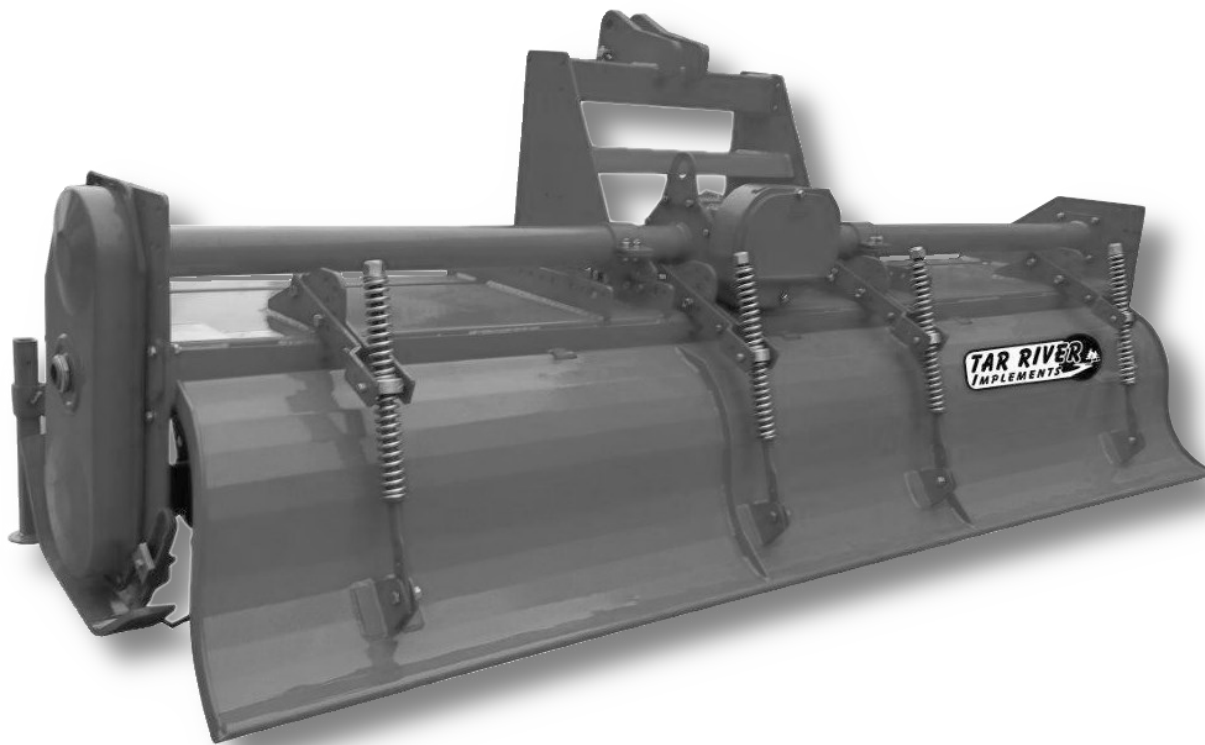

Rotary Tiller BXV & CXT Series



Operator's Manual

Page left blank intentionally

TO THE DEALER:

Assembly and proper installation of this product is the responsibility of the Tar River dealer. Read manual instructions and safety rules. Make sure all items on the Dealer's Pre-Delivery and Delivery Check Lists in the Owner's/Operator's Manual are completed before releasing equipment to the owner.

TO THE OWNER:

Read this manual before operating your Tar River equipment. The information presented will prepare you to do a better and safer job. Keep this manual handy for ready reference. Require all operators to read this manual carefully and become acquainted with all the adjustment and operating procedures before attempting to operate. Replacement manuals can be obtained from your selling dealer. The equipment you have purchased has been carefully engineered and manufactured to provide dependable and satisfactory use. Like all mechanical products, it will require cleaning and upkeep. Lubricate the unit as specified. Observe all safety information in this manual and safety decals on the equipment. For service, your authorized Tar River dealer has trained mechanics, genuine Tar River service parts, and the necessary tools and equipment to handle all your needs. Use only genuine Tar River service parts. Substitute parts will void the warranty and may not meet standards required for safe and satisfactory operation.

Record your implement model and serial number in the space provide below. Your dealer will need this information to give you prompt, efficient service.

Model Number: _____

Serial Number: _____

Date Purchased: _____

Table of Contents

Introduction	5
Technical Specifications	5
Safety	6
Safety Signal Words	6
General Safety Guidelines	7
Safety Decal Care	7
Before Operation	8
During Operation	9
Highway And Transport Operations	10-11
Operating Instructions.....	12-16
Maintenance	17-20
Torque Specifications	21
Parts Breakdown	23-57
Decals.....	58-59
Warranty	60

Introduction

Thank you for purchasing your Tar River Rotary Tiller. The CXT Series is specifically designed to tractors in the 60-130 horse power range.

Technical Specifications

- Gear drive transmission, 6 Blades per flange, PTO with slip-clutch protection, Solid A-frame, 6" Tilling depth, Powder coat paint

	CXT-086	CXT-095	CXT-104	CXT-112	CXT-121
Weight	1636 lbs.	1762 lbs.	1876 lbs.	2081 lbs.	2115 lbs.
Shipping weight	1735 lbs.	1862 lbs.	1895 lbs.	2317 lbs.	2410 lbs.
Working width	86"	95"	104"	112"	121"
Blades per flange	6	6	6	6	6
HP	60-130	70-130	75-130	80-130	85-130
PTO driveline	Series 4 S/C	Series 4 S/C	Series 4 S/C	Series 4 S/C	Series 4 S/C

Important Safety Information

Safety

It is important that you read the entire manual and to become familiar with this product before you begin using it. This product is designed for certain applications only. The manufacturer cannot be responsible for issues arising from modification. We strongly recommend this product not be modified and /or used for any application other than that for which it is designed. If you have any questions relative to a particular application, DO NOT use the product until you have first contacted us to determine if it can or should be performed on the product.

Read and understand this manual and all safety signs before operating and maintaining . Review the safety instructions and precautions annually.

Safety Signal Words

TAKE NOTE! This safety alert symbol found though out this manual is used to call you attention to instructions involving you personal safety and the safety of others. Failure to follow these instructions can result in injury or death.



**This symbol means:
Attention!
Become alert!
Your safety is involved!**

Note the use of the signal words, DANGER, WARNING and CAUTION with the safety messages. The appropriate signal word for each has been selected using the following guidelines:



DANGER: Indicates an imminently hazardous situation that, if not avoided, will result in death or serious injury. This signal word is to be limited to the most extreme situations typically for machine components which, for functional purposes, cannot be guarded.



WARNING: Indicates a potentially hazardous situation that, if not avoided, could result in death or serious injury, and includes hazards that are exposed when guards are removed. It may also be used to alert against unsafe practices.



CAUTION: Indicates a potentially hazardous situation that, if not avoided, may result in minor or moderate injury. It may also be used to alert against unsafe practices.

Important Safety Information

General Safety Guidelines

Safety of the operator is one of the main concerns in designing and developing a new piece of equipment. Designers and manufacturers build in as many safety features as possible. However, every year many accidents occur which could have been avoided by a few seconds of thought and a more careful approach to handling equipment. You, the operator, can avoid many accidents by observing the following precautions in this section. To avoid personal injury, study the following precautions and insist those working with you, or for you, follow them.

Replace any DANGER, WARNING, CAUTION or instruction safety decal that is not readable or is missing. Location of such decals are indicated in this manual. Do not attempt to operate this equipment under the influence of drugs or alcohol.

Review the safety instructions with all users annually.

This equipment is dangerous to children and persons unfamiliar with its operation. The operator should be a responsible adult familiar with farm machinery and trained in this equipment's operations. **Do not allow persons to operate or assemble this unit until they have read this manual and have developed a thorough understanding of the safety precautions and of how it works.**

To prevent injury of death, use a tractor equipped with a Roll Over Protection System (ROPS). Do not paint over, remove or deface any signs or warning decals on your equipment. Observe all safety signs and practice the instructions on them.

Never exceed the limits of a piece of machinery. If its ability to do a job, or to do so safely, is in question - **Don't try it!**



Safety Decal Care

- Keep safety signs clean and legible at all times.
- Replace safety signs that are missing or have become illegible.
- Replaced parts that displayed a safety sign should also display the current safety sign
- Safety signs are available from your Distributor or Dealer Parts Department or the factory.

Important Safety Information

How to install Safety Signs:

- Be sure that the installation area is clean and dry.
- Decide on the exact position before you remove the backing paper.
- Remove the smallest portion of the split backing paper.
- Align the decal over the specified area and carefully press the small portion with the exposed sticky backing in place.
- Slowly peel back the remaining paper and carefully smooth the remaining portion of the decal in place.
- Small air pockets can be pierced with a pin and smoothed out using the piece of decal backing paper.



Before Operation

- Carefully study and understand this manual.
- Do not wear loose-fitting clothing, which may catch in moving parts.
- Always wear protective clothing and substantial shoes.
- Assure that all tires are inflated evenly.
- Give the unit a visual inspection for any loose bolts, worn parts or cracked welds, and make necessary repairs. Follow the maintenance safety instructions included with this manual.
- Be sure that there are no tools lying on or in the equipment.
- Do not use the unit until you are sure that the area is clear, especially of children and animals.
- Don't hurry the learning process or take the unit for granted. Ease into it and become familiar with your new equipment.
- Practice operation of your equipment and its attachments. Completely familiarize yourself and other operators with its operation before using.
- Use a tractor equipped with a Roll Over Protection System (ROPS) and fasten your seat belt prior to starting engine.
- The manufacturer does not recommend usage of tractor with ROPS removed.
- Move tractor wheels to the widest recommended settings to increase stability.
- Securely attach to towing unit. Use a high strength, appropriately sized hitch pin with a mechanical retainer and attach safety chain.
- Do not allow anyone to stand between the tongue or hitch and the towing vehicle when backing up to the equipment.
- Do not use the unit until you are sure that the area is clear, especially of children and animals.

Important Safety Information



During Operation

- Children should not be allowed on the product.
- Clear the area of small children and bystanders before moving the feeder.
- If using a towing unit, securely attach feeder by using a hardened 3/4" pin, a metal retainer, and safety chains if required. Shift towing unit to a lower gear before going down steep downgrades, thus using the engine as a retarding force. Keep towing vehicle in gear at all times. Slow down for corners and rough terrain.
- Make sure you are in compliance with all local and state regulations regarding transporting equipment on public roads and highways. Lights and slow moving signs must be clean and visible by overtaking or oncoming traffic when feeder is transported.
- Beware of bystanders, **particularly children!** Always look around to make sure that it is safe to start the engine of the towing vehicle or move the unit. This is particularly important with higher noise levels and quiet cabs, as you may not hear people shouting.
- **NO PASSENGERS ALLOWED!** Do not carry passengers anywhere on, or in, the tractor or equipment, except as required for operation.
- Keep hands and clothing clear of moving parts.
- Do not clean, lubricate or adjust your equipment while it is moving.
- When halting operation, even periodically, set the tractor or towing vehicle brakes, disengage the PTO, shut off the engine and **remove the ignition key.**
- Be especially observant of the operating area and terrain. Watch for holes, rocks or hidden hazards. Always inspect the area prior to operation.
- **DO NOT** operate near the edge of drop-offs or banks.
- **DO NOT** operate on steep slopes as overturns may result.
- Operate up and down (not across) intermediate slopes. Avoid sudden starts and stops.

Important Safety Information



Highway and Transport Operations

- Adopt safe driving practices.
- Keep the brake pedals latched together at all times. **Never use independent braking with machine in tow as loss of control and/or upset of unit can result.**
- Always drive at a safe speed relative to local conditions and ensure that your speed is low enough for an emergency stop to be safe and secure. Keep speed at a minimum.
- Reduce speed prior to turns to avoid the risk of overturning.
- Avoid sudden uphill turns on steep slopes.
- Always keep the tractor or towing vehicle in gear to provide engine braking when going downhill. Do not coast.
- Do not drink and drive!
- Comply with state and local laws governing highway safety and movement of farm machinery on public roads.
- Use approved accessory lighting flags and necessary warning devices to protect operators of other vehicles on the highway during daylight and nighttime transport. Various safety lights and devices are available from your dealer.
- The use of flashing amber lights is acceptable in most localities. However, some localities prohibit their use. Local laws should be checked for all highway and marking requirements.
- When driving the tractor and equipment on the road or highway under 40 kph (20 mph) at night or during the day, use the amber warning lights and a slow moving vehicle (SMV) identification emblem.
- Plan your route to avoid heavy traffic.
- Be a safe and courteous driver. Always yield to oncoming traffic in all situations, including narrow bridges, intersections, etc.
- Be observant of bridge loading ratings. Do not cross bridges rated at lower than the gross weight at which you are operating.
- Watch for obstructions overhead and to the side while transporting.
- Always operate in a position to provide maximum visibility at all times. Make allowances for increased length and weight of the equipment when making turns, stopping the unit, etc.
- Pick the most level route when transporting across fields. Avoid the edges of ditches or gullies and steep hillsides.
- Be extra careful when working in inclines.

Important Safety Information



Highway and Transport Operations

- Maneuver the tractor or towing vehicle at safe speeds.
- Avoid overhead wires or other obstacles. Contact with overhead lines could cause serious injury or death.
- Avoid loose fill, rocks and holes, they can be dangerous for equipment operation or movement.
- Allow for unit length when making turns,
- Operate the towing vehicle from the operator's seat only.
- Never stand alongside of unit with engine running or attempt to start engine and/or operate machine while standing alongside of unit.
- Never leave running equipment attachments unattended.
- As a precaution, always recheck the hardware on equipment following every 100 hours of operation. Correct all problems. Follow the maintenance safety procedures.

Operating Instructions



Before attaching the rotary tiller to the tractor, check the unit to ensure there is oil in the top and side gearbox. See Maintenance section for lubricant specifications. Before beginning operation, check oil and grease points.

Note: Gearboxes are shipped with high performance gear grease, add indicated lubricants to specified levels. It is okay to use variable viscosity gear oils.

Oil Level:

Center Gearbox: Level indicated on dipstick (SAE 90)
 Side gearbox drive: Fill to oil drain plug on lower front of cover (SAE 140)
 Right rotor bearing: Grease if cap has grease nipple. Otherwise fill to side drain plug. (SAE 90 or SAE 140)

Grease: PTO shaft cross and bearings



Attaching to the tractor

1. With the Rotary Tiller on a level surface, back the Cat. 1 tractor so the tractor lift arms are even with the unit's lower hitch pins. Lower or raise the tractor hitch arms until the 7/8" bushing in the arm is inside the clevis of lower hitch points. Be sure nothing is between the tractor and the tiller before backing up.
2. Insert the lower hitch pin through the lower hitch blocks and the tractor arm. The YCT series tillers have adjustable lower hitch blocks that can be slide to facilitate usage on larger tractors.
3. Secure the lift arm in place by using a 7/16" lynch pin or other fastener.
4. Repeat with the other arm.
5. Connect the driveline to the tractor's PTO output shaft. Secure it in place.
6. Connect the tractor top link to the upper hitch point of the rotary tiller.
7. Start the tractor and slowly raise the tiller. Check for drawbar interference. Be sure that the PTO driveline does not bottom out when lifting the machine to it's maximum height. If it does appear that it could bottom out, it is necessary to shorten the PTO driveline. (See Shortening a PTO Driveline section). Ensure that in the working position there is an overlap of a minimum of 1/3 the length of each profile.

Operating Instructions

Attaching the PTO shaft:

Before installing the PTO shaft make sure that the RPM rating and the direction of rotation match those of the tractor. Carefully read the PTO shaft and tractor instructions. Before operation, make sure that the guards are installed on the power take off of the tractor and PTO shaft. Make sure that they cover the PTO shaft throughout its length. Note: The PTO shaft may be too long and require shortening. See “**Shortening a PTO driveline**” below.

Press the locking pin on the PTO yoke and slide yoke on to the PTO of the tractor until the pin seats. Pull on PTO shaft to make certain it is locked in place. Repeat the procedure for the machine end. Attach the PTO cover’s safety chains to a stationary part of the tractor. Leave some slack in the chain to accommodate movement.

Shortening a PTO driveline:

1. With the machine attached to the tractor’s 3-point hitch, and the PTO shaft not installed, separate the PTO shaft. Attach the machine end to the machine and the other end to the tractor PTO input shaft.
2. Raise the machine by using the tractor’s hydraulic 3-point hitch to its maximum lift height.
3. Hold the half shafts next to each other and mark them so each end is approximately 1/2” from hitting the end of the telescopic profiles.
4. Shorten the inner and outer guard tubes equally.
5. Shorten the inner and outer profiles by the same length as the guard tubes. Using a rattail file, round off all sharp edges and burrs. Grease the telescopic profile generously before reassembling.

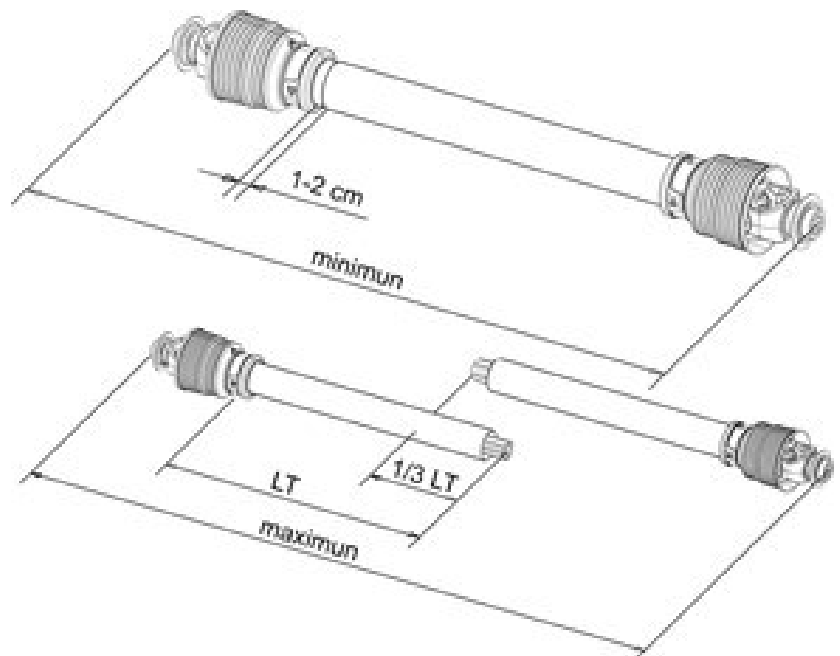

Fig. 4



When fully extended, the tubes must overlap by at least 1/3 of the length of the pipes (LT). When retracted, the min. acceptable clearance is 1-2 cm (3/8”-3/4”)

Scan the QR code below for more detailed information on PTO installation.



Operating Instructions

Slip clutch adjustments

Slip clutch must be adjusted before first use or after a storage period.

1. Using a marker, scribe a line across the exposed edges of the clutch plate and friction discs.
2. Back off compression nuts to free friction discs by turning each nut *exactly* 2 revolutions.
3. Start the tractor and run the driveline at a low idle to slip the friction discs. This will remove the dirt, corrosion and surface floss from the clutch plate faces.
4. Disengage PTO, shut down tractor and wait for all components to come to a complete stop.
5. Inspect the clutch and ensure that the scribed markings on the disc and plates have changed position. If any two marks are still aligned, this is an indication that these discs have not slipped. It may be necessary to completely disassemble the clutch to free them up.
6. After ensuring all discs are free, tighten the compression nuts, uniformly, *exactly* 2 revolutions to reset the clutch original pressure.

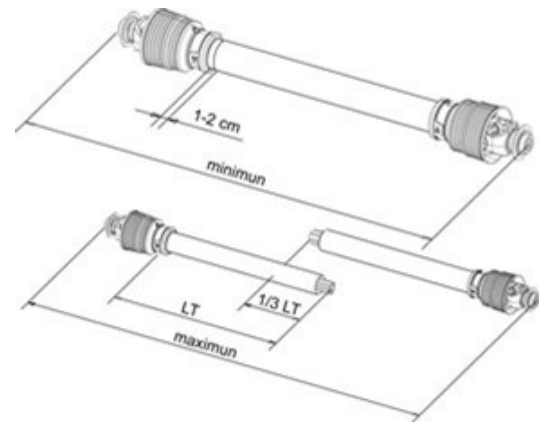

Caution: Slip Clutches may become hot. Do Not Touch. Keep the slip clutch area clear of a material that may catch fire. Slip clutches have adjustable torque settings. The torque setting varies with the different compression of each spring. All the springs should have an equal amount of compression.

Important: Do not over-tighten the compression nuts as this may impair performance or cause premature wearing of the slip clutch.

Checking for PTO Driveline Interference:

1. Begin with the PTO Driveline level (0 degrees). Raise the implement at an angle no greater than 25 degrees from level. Check for any interference and the length of the PTO Driveline extended. Do not exceed the maximum extended length!
2. Next lower the PTO Driveline at an angle no greater than 25 degrees from level. Check for any interference and the length of the PTO Driveline extended. Do not exceed the maximum extended length!

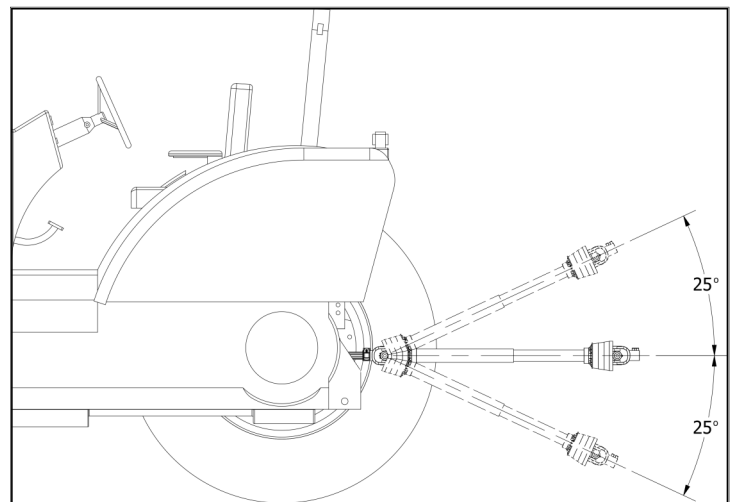

Operating Instructions

Working Depth Adjustment

The working depth is controlled by raising or lowering the side skids. If the skids are raised, the working depth increases. By lowering the skids, the tilling depth will decrease.

Tailgate adjustment

Position the tailgate to its desired opening by fitting the bolts into the appropriate holes of the adjustment flange located on the top of the main frame. To adjust the degree of tension, tighten or loosen up on the 24mm nut on the top of the spring support rod.

Multi-Speed Gearbox

On certain models, the tiller will come standard with a multi-speed gearbox to allow rotor speed changes. This is particularly useful on uneven ground so as the tractor speed can maintain a constant ground speed and rotor speed to adapt to different soil conditions.

To change the rotor speed, do the following:

1. Ensure the gearbox is not too hot to work safely without burning your hands.
2. Tilt the tiller forward to prevent excessive oil from coming out of the back cover.
3. Unscrew the bolt holding the rear cover of the gearbox.
4. Adjust the gears inside the gearbox to obtain the desired speed.
5. Replace cover and tighten bolts.

IMPORTANT: Make sure the spacers located behind the gears do not fall into the gearbox! If this happens damage to the gearbox or gears can occur.

BXV				CXT			
INPUT	Left Gear	Right Gear	Rotor Speed	INPUT	Left Gear	Right Gear	Rotor Speed
540	22	16	140	540	23	17	143
540	20	18	174	540	21	19	175
540	18	20	213	540	19	21	214
540	16	22	266	540	17	23	262

Operating Instructions

Start up

After making the necessary adjustments, lower the rotary tiller until the blades are a couple of inches from the ground. Engage the PTO and slowly lower the tiller to begin working.

Removal and Storage

1. After finishing, remove the rotary tiller from the tractor.
 2. Put the PTO driveline in a safe location so it will not become damaged.
 3. Clean and dry the equipment.
 4. Replace any damaged or worn parts.
 5. Check all bolts and nuts for tightness.
 6. Lubricate and protect the machine from the elements.
- Following operation, or when unhitching, stop the tractor or towing vehicle, set the brakes,



Following Operation

disengage the PTO and all power drives, shut off the engine and **remove the ignition keys.**

- Store the unit in an area away from human activity.
- Do not park equipment where it will be exposed to livestock for long periods of time.
Damage and livestock injury could result.
- Do not permit children to play on or around the stored unit.
- Make sure all parked machines are on a hard, level surface and engage all safety devices.
- Wheel chocks may be needed to prevent unit from rolling.

Maintenance



Performing Maintenance

- Good maintenance is your responsibility. Poor maintenance is an invitation to trouble.
- Make sure there is plenty of ventilation. Never operate the engine of the towing vehicle in a closed building. The exhaust fumes may cause asphyxiation.
- Be certain all moving parts on attachments have come to a complete stop before attempting to perform maintenance.
- Always use the proper tools or equipment for the job at hand.
- Use extreme caution when making adjustments.
- Never replace hex bolts with less than grade five bolts unless otherwise specified.
- After servicing, be sure all tools, parts and service equipment are removed.
- Where replacement parts are necessary for periodic maintenance and servicing, genuine factory replacement parts must be used to restore your equipment to original specifications. The manufacturer will not claim responsibility for use of unapproved parts and/or accessories and other damages as a result of their use.
- If equipment has been altered in any way from original design, the manufacturer does not accept any liability for injury or warranty.

Maintenance Schedule

8 hours

Grease the Rotor support (**GP grease**)

Grease PTO shaft cross & bearings (**GP grease**)

Check Hardware for tightness

16 hours

Check oil level in center gearbox (**SAE 90W**)

Check oil level in side gearbox (**EP 00 Multi-purpose Grease**)

Check Hardware for tightness

200 hours

Check oil level in center gearbox (**SAE 90W**)

Check oil level in side gearbox (**EP 00 Multi-purpose Grease**)

Check Hardware for tightness

Replacing Blades

In order for the tiller to perform optimally, make sure the tiller blades are in good working condition and their bolts and nuts tight. Always replace the blades with the bolt head against the blade and the washer and nut on the flange side to help prevent the blades from loosening. When several blades are to be replaced, replace them one blade at a time in order to maintain the scroll pattern on the rotor.

Note: To determine Left or Right Blades, hold the blade by the bolt hole end and the cutting edge facing downward. If the blade curves to the left it is a left-hand blade, curving to the right indicates a right-hand blade.

Maintenance

Lubrication

Side Gearbox:

- Run the tiller long enough to warm the oil.
- Level the tiller, shut off tractor and set the park brake. Remove the “Lower Plug”. The warmed lubricant should reach the bottom of the “Lower Plug” hole as shown.
- If the lubricant level is below the bottom of the “Lower Plug” hole, add oil through the “Fill Plug” hole or “Lower Plug” hole. Add (EP 00 Multi-purpose Grease) to bring the level to the normal operating range.
- Replace and tighten all plugs before operating the tiller.

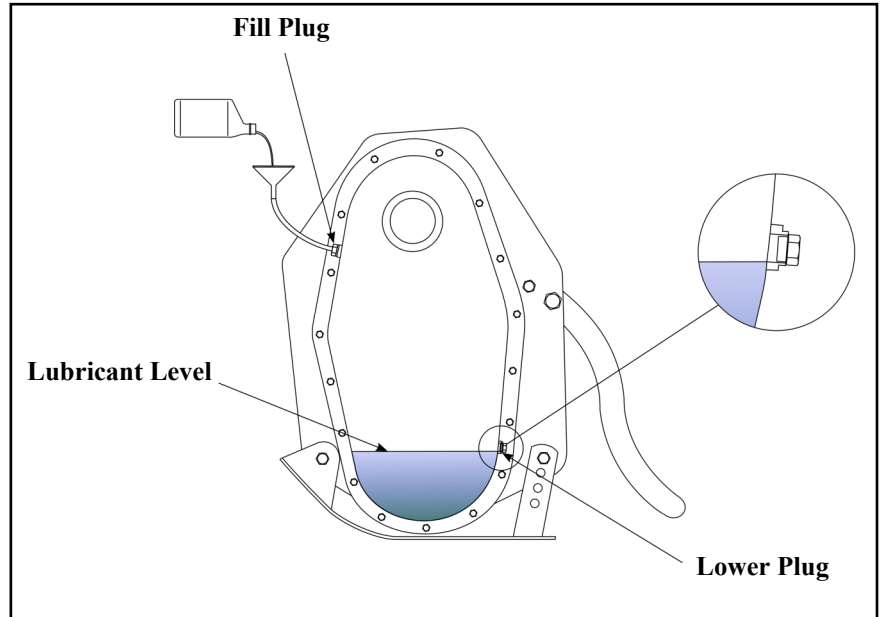

Note: Check after 16 hours of use.

Center Gear Box:

- Unscrew and remove the dipstick and wipe clean.
- Screw in dipstick and hand tighten only.
- Once again, remove the dipstick and check the oil level. If the oil level is on or below the low level mark, add enough oil (SAE 90W) to the gearbox to bring the oil level up to normal operating range between the low mark and high mark.
- Screw in dipstick before operating the tiller.
- Do not overfill

Note: Check after 16 hours of use.

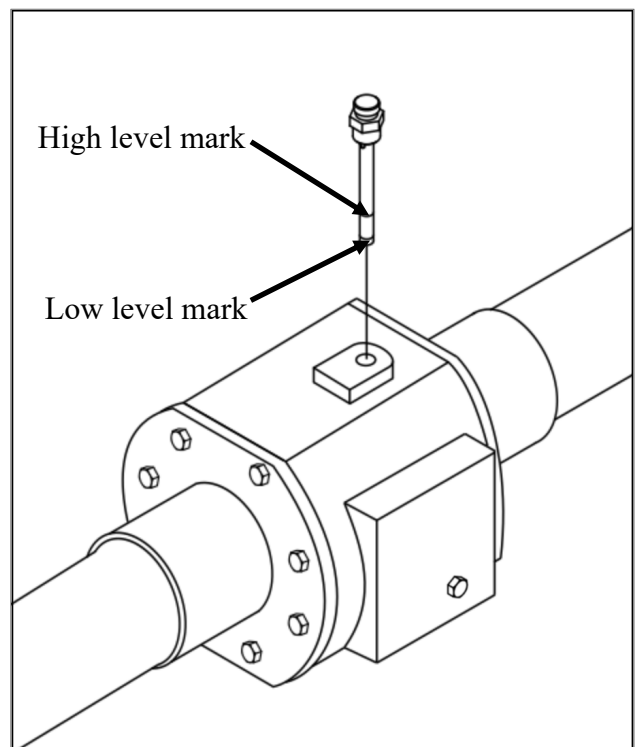

Maintenance

Lubrication

Gearbox Input Shaft:

When attaching and reattaching the PTO driveline, be sure to lubricate all surfaces of the gearbox input shaft with Multi-Purpose Grease.

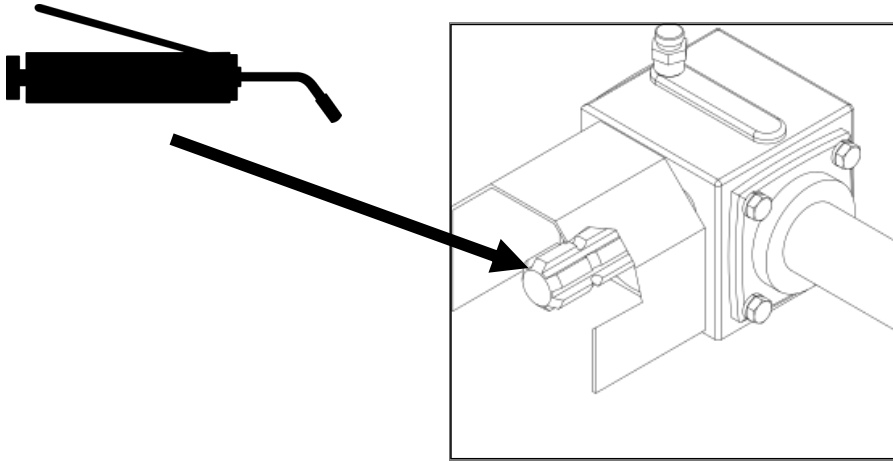

PTO Driveline:

Grease the PTO Driveline U-joints with Multi-Purpose Grease every 8 hours of use.

Slide apart the two PTO Driveline halves from each other. Clean and coat (every 20 hours of use) the inner tube of the PTO Driveline shaft with a thin layer of Multi-Purpose Grease and reassemble.

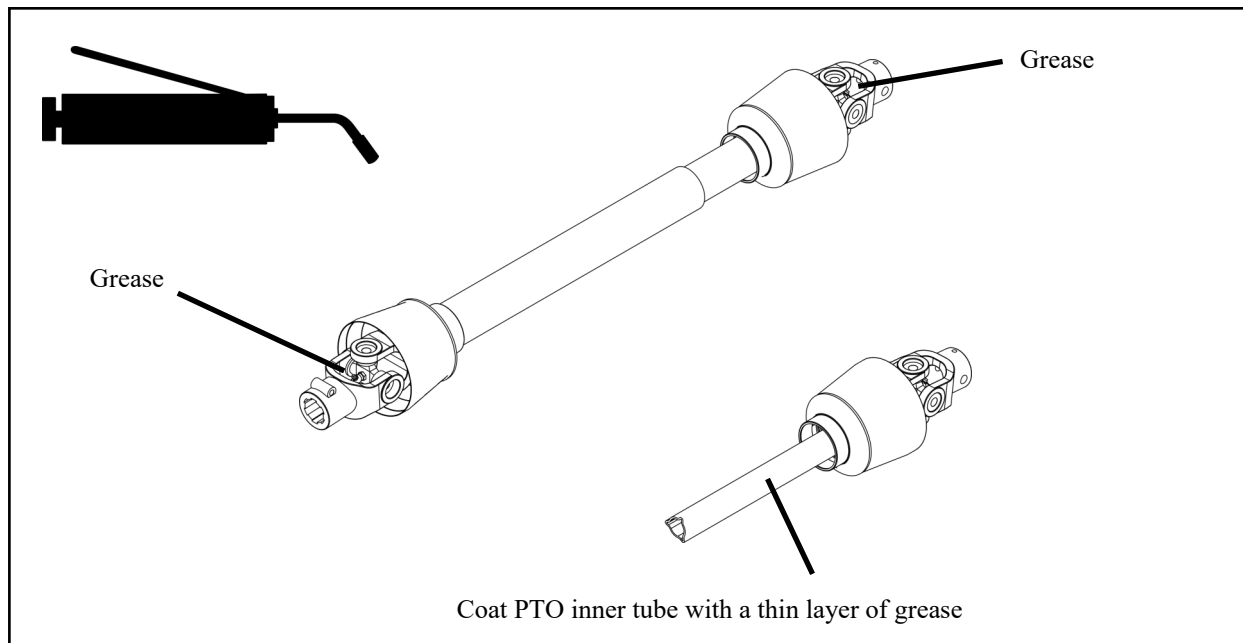

Maintenance

Lubrication

Rotor Support:

Remove the breather plug on the RH side of the tiller and lubricate with Multi-Purpose Grease every 8 hours of use. Replace the breather plug before operating.

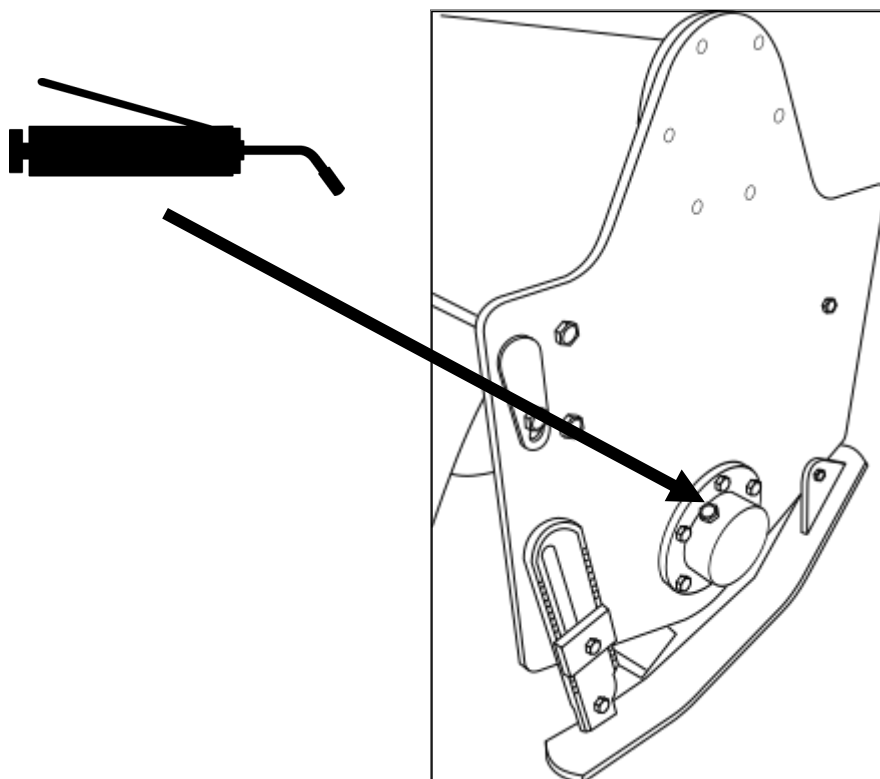

Torque Specifications

Torque Specifications for Common Bolt Sizes															
Inches		Bolt Head Identification						Metric		Bolt Head Identification					
										5.8		8.8		10.9	
Bolt size (inches)	Thread pitch	Grade 2		Grade 5		Grade 8		Class 5.8		Class 8.8		Class 10.9			
		N.m	ft-lb	N.m	ft-lb	N.m	ft-lb	N.m	ft-lb	N.m	ft-lb	N.m	ft-lb		
1/4"	20	7	5	11	8	16	12	M5	0.08	4	3	6	4	9	7
1/4"	28	8	6	13	10	19	14	M6	1	6	4	10	7	15	11
5/16"	18	15	11	24	17	33	25	M8	1.25	16	12	25	18	36	27
5/16"	24	17	13	26	19	37	27	M8	1	17	13	26	19	38	28
3/8"	16	27	20	42	31	59	44	M10	1.5	31	23	48	35	71	52
3/8"	24	31	23	47	35	67	49	M10	1.25	33	24	51	38	75	55
7/16"	14	43	32	67	49	95	70	M10	1	35	26	53	39	78	58
7/16"	20	48	36	75	55	106	78	M12	1.75	54	40	84	62	123	91
1/2"	13	66	48	102	75	144	106	M12	1.5	56	41	87	64	128	94
1/2"	20	75	55	115	85	163	120	M12	1.25	59	44	90	66	133	98
9/16"	12	95	70	147	109	208	154	M14	2	84	62	133	98	195	144
9/16"	18	106	79	164	121	232	171	M14	1.5	94	69	142	105	209	154
5/8"	11	132	97	203	150	287	212	M16	2	131	97	206	152	302	223
5/8"	18	149	110	230	170	325	240	M16	1.5	141	104	218	161	320	236
3/4"	10	233	172	361	266	509	376	M18	2.5	181	133	295	218	421	310
3/4"	16	261	192	403	297	569	420	M18	2	196	145	311	229	443	327
7/8"	9	226	167	582	430	822	606	M18	1.5	203	150	327	241	465	343
7/8"	14	249	184	642	473	906	668	M20	2.5	256	189	415	306	592	437
1"	8	339	250	873	644	1232	909	M20	1.5	288	212	454	335	646	476
1"	12	371	273	955	704	1348	995	M22	2.5	344	254	567	418	807	595
1-1/8"	7	480	354	1077	794	1746	1288	M22	1.5	381	281	613	452	873	644
1-1/8"	12	539	397	1208	891	1958	1445	M24	3	444	327	714	526	1017	750
1-1/4"	7	677	500	1519	1120	2463	1817	M24	2	488	360	769	567	1095	808
1-1/4"	12	750	553	1682	1241	2728	2012	M27	3	656	484	1050	774	1496	1103
1-3/8"	6	888	655	1992	1469	3230	2382	M27	2	719	530	1119	825	1594	1176
1-3/8"	12	1011	746	2268	1673	3677	2712	M30	3.5	906	668	1420	1047	2033	1499
1-1/2"	6	1179	869	2643	1949	4286	3161	M30	2	1000	738	1600	1180	2250	1659
1-1/2"	12	1326	978	2974	2194	4823	3557	M36	4	1534	1131	2482	1830	3535	2607

Notes:

This chart is an approximate estimate of torque values.

Always tighten hardware to these values unless a different torque value or tightening procedure is listed for a specific application.

Fasteners must always be replaced with the same grade as specified in the manual.

Always use the proper tool for tightening hardware: SAE for SAE hardware and Metric for Metric hardware.

Make sure that fastener threads are clean and that you properly start thread engagement.

Page left blank intentionally



Rotary Tiller BXV & CXT Series

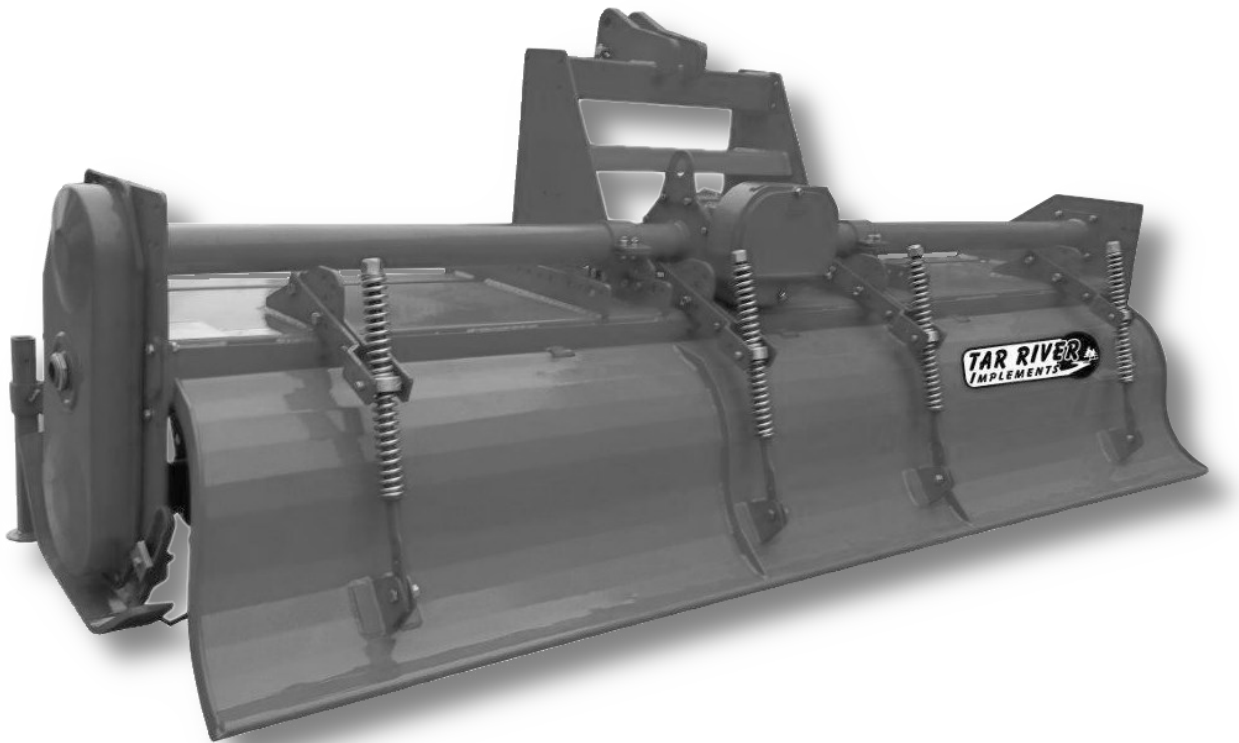

Parts Manual

Rev. 10/25

BXV-075, BXV-085, BXV-094, BXV-104

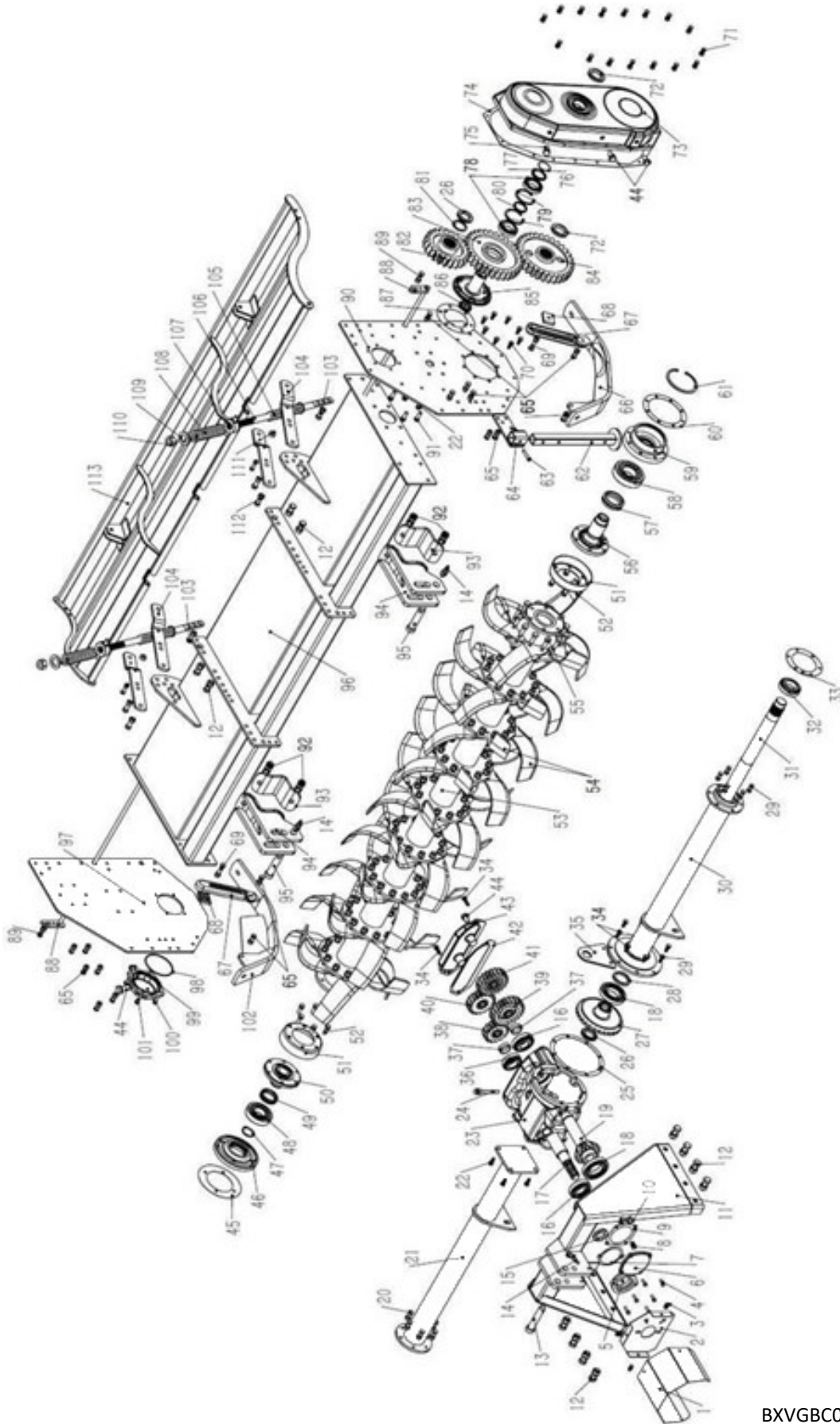

BXVGBC001 Gearbox Complete

BXV-075, BXV-085, BXV-094, BXV-104

Item	Part #	Description	Qty.
1	BV0317	PTO shield	1
2	BV0321	PTO shield support	1
3	BM812516	Bolt- M8 x 1.25 x 16	3
4	BM1012530	Bolt- M10 x 1.25 x 30	6
5	BV0320	Bearing support	1
6	BV0315	Gearbox cap	1
7	BV0318	Gasket - Input Shaft- M107 x 91 x 1	1
8	BM1012520	Bolt- M10 x 1.25 x 20	1
9	BV0314	Gasket Bearing Cover- M150 x 112 x 1	1
10	BV0408	Spacer- Right Rotor Support- M63 x 50 x 4	1
11	BV0101	A Frame	1
12	BM161540	Bolt- M16 x 1.5 x 40	12
13	BV0103	Top Hitch Pin	1
14	SB100756	Lynch Pin- M10mm	3
15	OS406210	Oil Seal- M40 x 62 x 10	1
16	B30308JR	Bearing- 30308JR	2
17	BV0319	Input Shaft	1
18	B30212JR	Bearing- 30212JR	2
19	BV0316	Pinion Shaft	1
20	BM1012535	Bolt- M10 x 1.25 x 35	6
21	BV0301-75	Gearbox Support Tube BXV-076	-
	BV0301-85	Gearbox Support Tube BXV-086	-
	BV0301-94	Gearbox Support Tube BXV-094	-
	BV0301-104	Gearbox Support Tube BXV-104	-
22	BM1212530	Bolt- M12 x 1.25 x 30	5
23	BV0313	Housing -Gearbox	1
24	BV0323	Dip Stick	1
25	BV0309	Gasket - Center Gearbox Left Side 240 x 206 x0.5	1
26	SLNM4515	Spanner locking nut M45-1.5	2
27	BV0324	Ring Gear	1
28	OS607508	Oil Seal- M60 x 75 x 8	1
29	BM1012530	Bolt- M10 x 1.25 x 30	12
30	BV0310-75	Gearbox Shaft Tube Housing - BXV-076	-
	BV0310-86	Gearbox Shaft Tube Housing - BXV-086	-
	BV0310-94	Gearbox Shaft Tube Housing - BXV-094	-
	BV0310-104	Gearbox Shaft Tube Housing - BXV-104	-

BXV-075, BXV-085, BXV-094, BXV-104

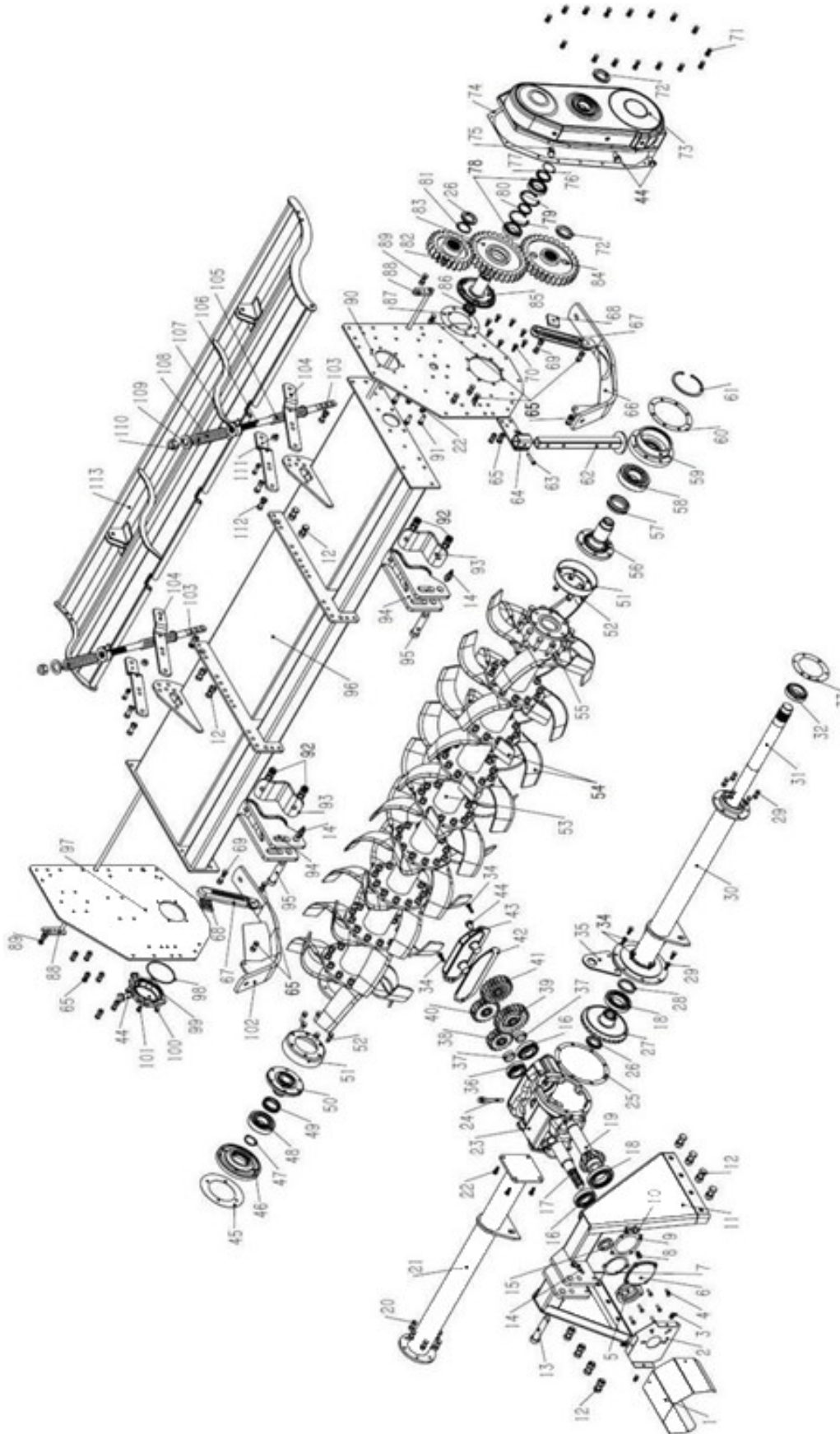

BXVGBC001 Gearbox Complete

BXV-075, BXV-085, BXV-094, BXV-104

Item	Part #	Description	Qty.
31	BV0311-75	Drive Shaft -BXV-076	-
	BV0311-86	Drive Shaft -BXV-086	-
	BV0311-94	Drive Shaft -BXV-094	-
	BV0311-104	Drive Shaft -BXV-104	-
32	B32210JR	Bearing- 32210JR	1
33	BV0312	Gasket Drive Shaft—162 x 111 x 1	1
34	BM1012535	Bolt- M10 x 1.25 x 35	4
35	BV0322	Gearbox Lift Bracket	1
36	B32208JR	Bearing 32208JR	1
37	BV0308	Spacer for Exchange Gear 48 x 40x15	2
38	BV0304	Exchange Gear- Z16	1
39	BV0307	Exchange Gear- Z22	1
40	BV0303	Exchange Gear- Z18	1
41	BV0306	Exchange Gear- Z20	1
42	BV0302	Gasket - Rear Cover	1
43	BV0305	Rear Cover	1
44	OP1615	Oil Plug- M16 x 1.5	4
45	BV0407	Gasket for Rotor- Right Side of Tiller	1
46	BV0406	Bearing Support - Right Side	1
47	SRE-50	Snap Ring- M50 External	1
48	B20310C	Bearing- 20310C	1
49	OSHF0610	Floating Oil Seal - HF0610	1
50	BV0405	Rotor Support Shaft - Right	
51	BV0403	Rotor Shield	2
52	BM1212535	Bolt- M12 x 1.25 x 35	12
53	BV0401 - 75	Rotor Shaft - BXV-075	1
54	BV0210R	Tiller Tine- Right	24-27-30-33
	BV0210L	Tiller Tine- Left	24-27-30-33
55	BM141540	Bolt- 14 x 1.5 x 40	96-108-120-132
	LW14	Lock Washer- M14	96-108-120-132
	NM1415	Nut- M14 x 1.5	96-108-120-132
56	BV0402	Rotor Support Shaft - Left	1
57	OSHF0720A	Floating Oil Seal - HF0720A	1
58	B21312	Bearing- 21312	1
59	BV0401	Bearing support	1

BXV-075, BXV-085, BXV-094, BXV-104

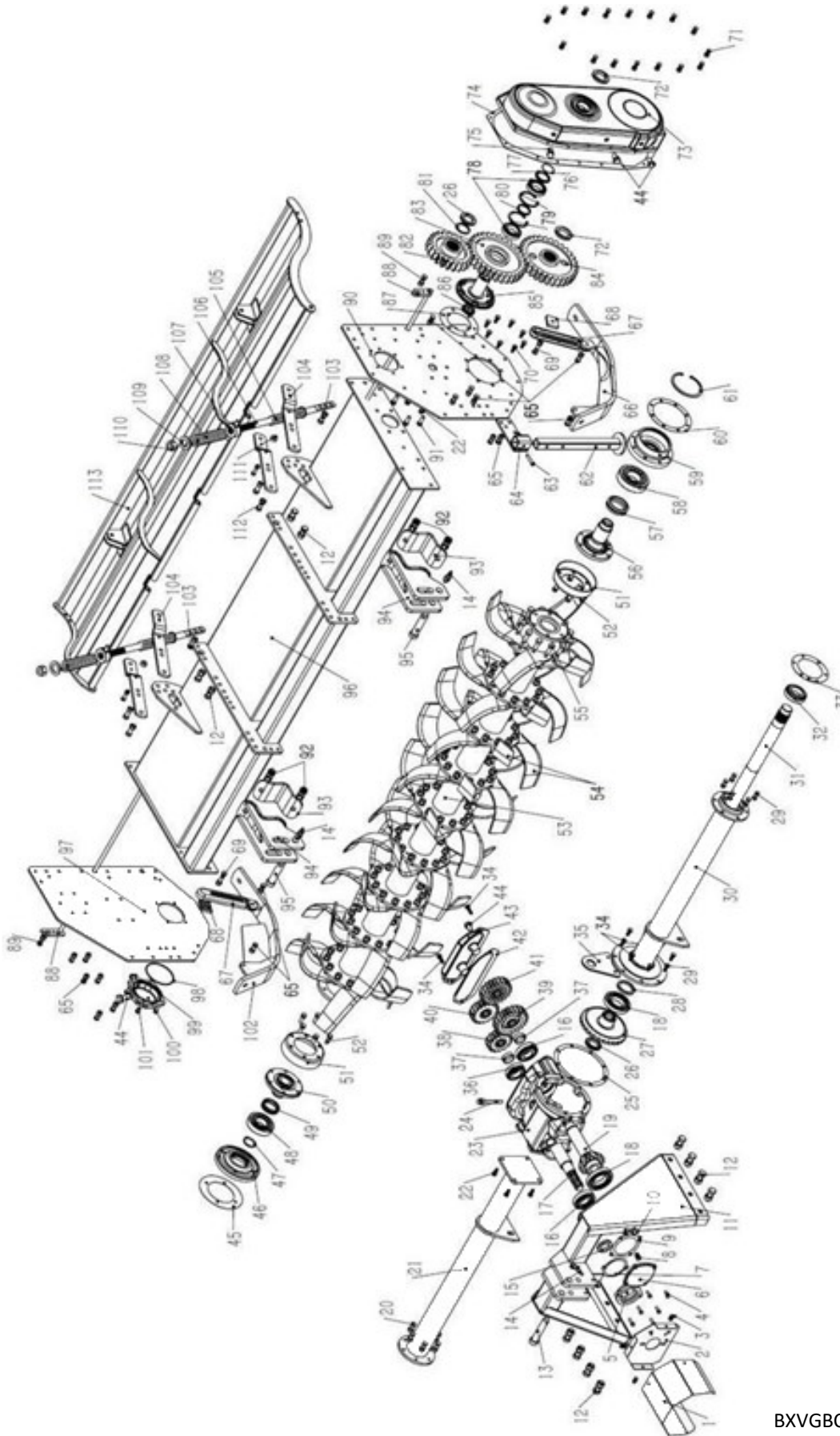

BXVGBC001 Gearbox Complete

BXV-075, BXV-085, BXV-094, BXV-104

Item	Part #	Description	Qty.
60	BV0511	Gasket for Rotor- Left Side	1
61	SRI-130	Snap Ring- M130 - Internal	1
62	BV0702	Stand	1
63	BV0703	Lynch Pin- M10 x 55	1
64	BV0701	Bracket - Stand	1
65	BM1212535	Bolt- M12 x 1.25 x 35	16
66	BV0902	Skid Weldment -Left	1
67	BV0801	Skid Adjustment Bracket	2
68	BV0802	Skid Adjustment Stop	2
69	BM1212560	Bolt- M12 x 1.25 x 60	2
70	BM1012525	Bolt- M10 x 1.25 x 25	8
71	BM1012525	Bolt- M10 x 1.25 x 25	14
72	SLNM5015	Spanner locking nut M50 x 1.5	2
73	BV0500	Gear Cover	1
74	BV0507	Gasket- Gear Cover	1
75	OP1615B	Breather Cap - M16 x 1.5	1
76	OR50x18	O-Ring- M50 x 1.8	1
77	BV0503	Spacer- Idler Gear- M63.5 x 50 x 6.5	1
78	B32010JR	Bearing- 32010JR	
79	SRI-80	Snap Ring- Internal- M80	2
80	BV0505	Gasket- Center Gear- M57 x 50 x 5	1
81	BV0506	Spacer- Top Gear- M63 x 50 x 2	1
82	BV0508	Gear- Top- Z-23	1
83	BV0502	Gear- Idler- Z-31	1
84	BV0501	Gear- Bottom- Z-31	1
85	BV0510	Idler Gear Hub	1
86	LN3515	Self-locking Nut- M35 x 1.5	1
87	BV0509	Gasket- Idler Gear hub- M170 x 140 x 1	1
88	BV0605-75	Rod- Tail Gate- BXV-075	2
	BV0605-85	Rod- Tail Gate- BXV-085	2
	BV0605-94	Rod- Tail Gate- BXV-094	2
	BV0605-104	Rod- Tail Gate- BXV-0104	2
89	BM1212545	Bolt- M12 x 1.25 x 45	2
90	BV0506	Side Board- Left	1
91	BM1212540	Bolt- M12 x 1.25 x 40	4

BXV-075, BXV-085, BXV-094, BXV-104

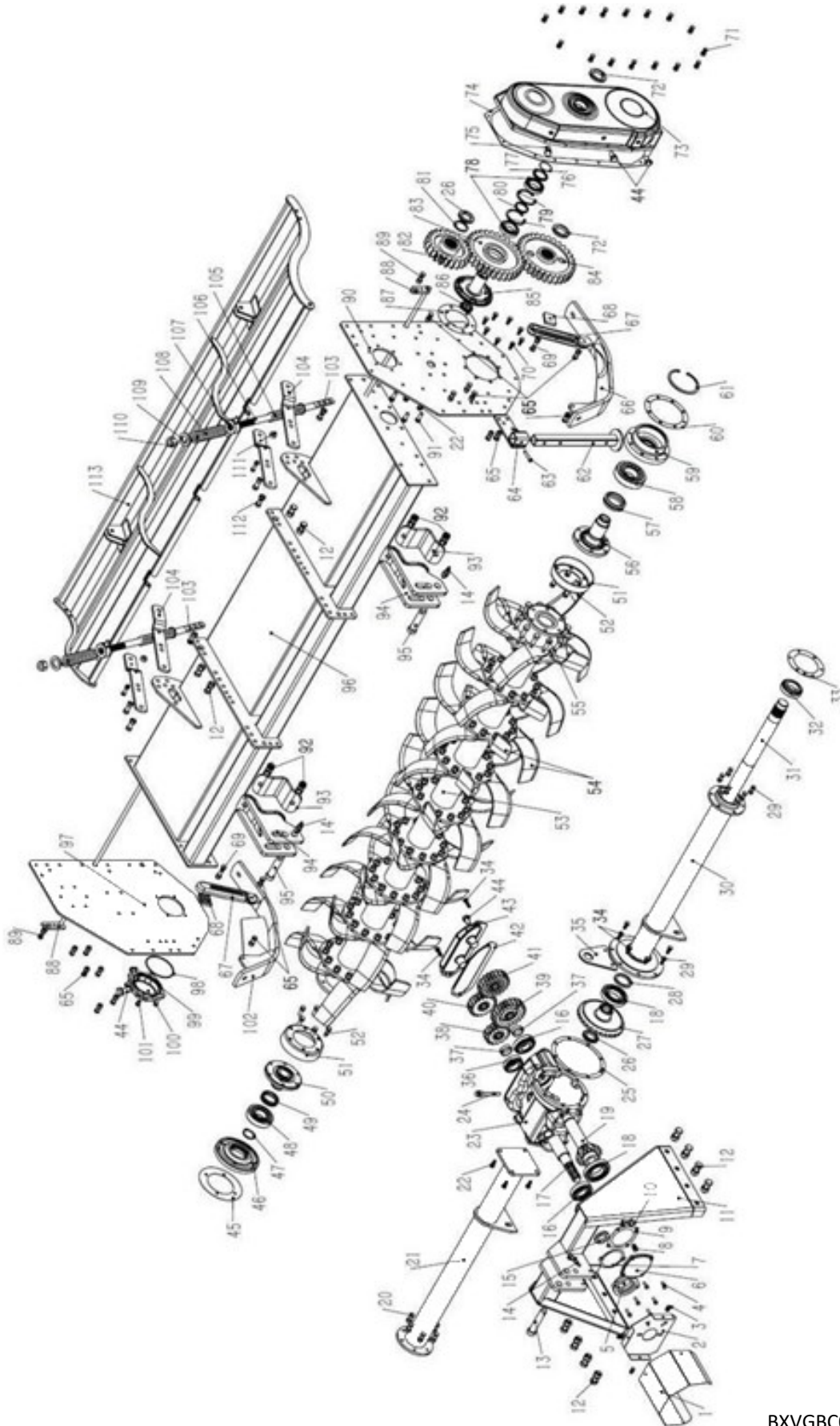

BXVGBC001 Gearbox Complete

BXV-075, BXV-085, BXV-094, BXV-104

Item	Part #	Description	Qty.
92	BM181550	Bolt- M18 x 1.5 x 50	4
93	BV0204	Hitch Block Support	2
94	BV0203	Lower Hitch Block	2
95	BV0205	Lower Hitch Pin	2
96	BV0201-75	Main Frame - BXV-075	1
	BV0201-85	Main Frame - BXV-085	1
	BV0201-94	Main Frame - BXV-094	1
	BV0201-104	Main Frame - BXV-104	1
97	BV0202	Side Board - Right	1
98	OR118x355	O-Ring- M118 x 3.55	1
99	OP12125	Oil Plug- M12 x 1.25	1
100	BV0409	Rotor Cap	1
101	BM1212540	Bolt- M12 x 1.25 x 40	4
102	BV0901	Skid Weldment- Right	1
103	BM1012545	Bolt- M10 x 1.25 x 45	2
104	BV0607	Bracket- Tailgate Spring	4
105	BV0609	Lower Spring- Tailgate- M184	2
106	BV0605	Rod- Tailgate	2
107	BV0606	Spring Bushing	2
108	BV0601	Upper Spring- Tailgate- M175	2
109	FW24	Flat Washer- M24	2
110	LN2415	Self-Locking Nut- M24 x 1.5	2
111	BV0604	Spacer- Tailgate Brackets- M26 x 10.5 x 10	2
112	BM141545	Bolt- M14 x 1.5 x 45	6
113	BV0602-075	Tailgate- BXV-075	1
	BV0602-085	Tailgate- BXV-085	1
	BV0602-094	Tailgate- BXV-094	1
	BV0602-104	Tailgate- BXV-104	1
	147130	Complete PTO - Series 80 - 220mm Slip Clutch	
	180-510-80	Friction Disc – 6.30” OD	
	BXVGB001	Complete Gearbox	

CXT Series Rotary Tiller (Version 1)

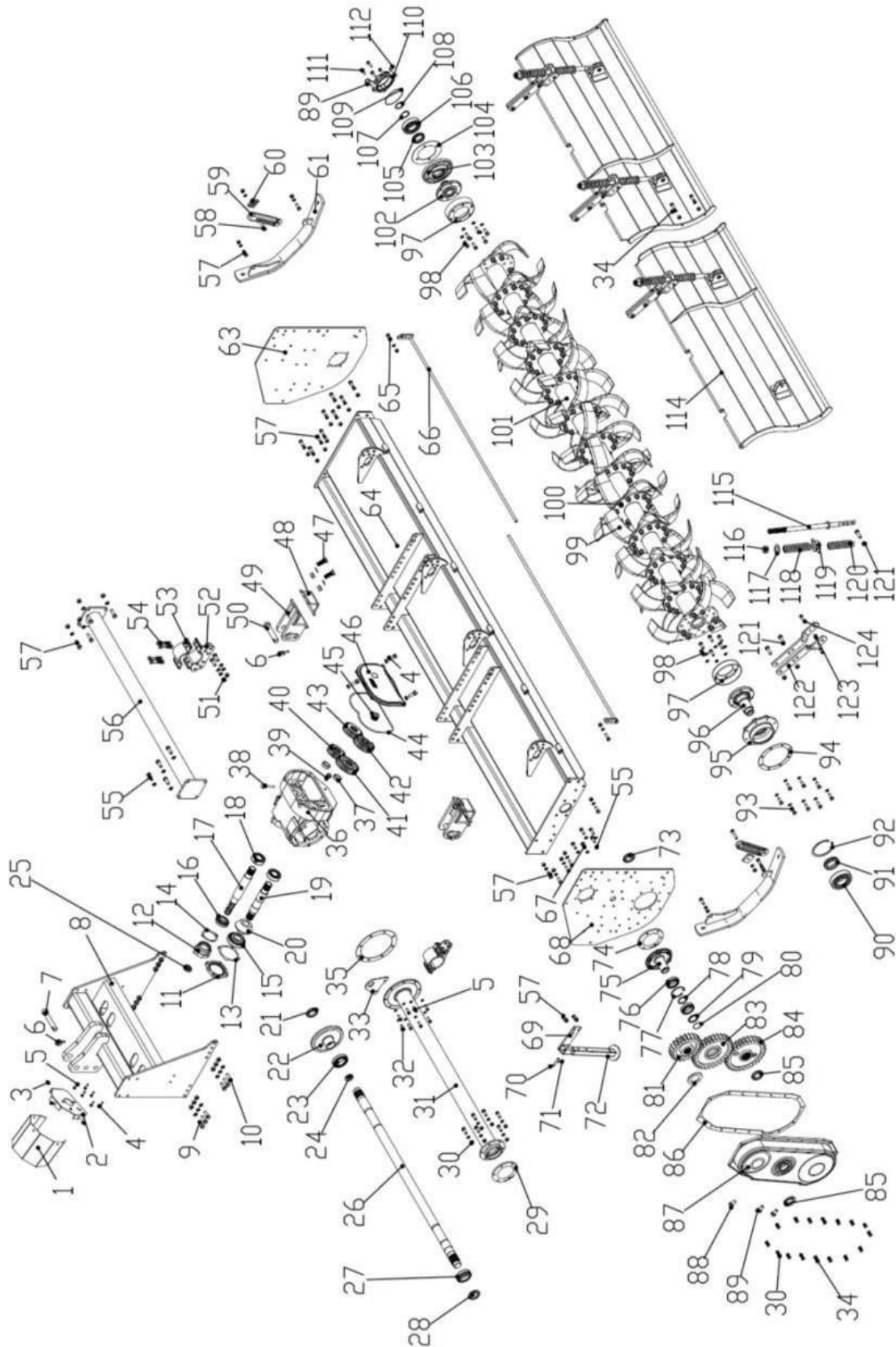

CXTGBC001 Gearbox Complete

CXT Series Rotary Tiller (Version 1)

Item	Part #	Description	Qty.
1	BV0317	PTO shield	1
2	BV0321	PTO shield support	1
3	BM812516	Bolt- M8 x 1.25 x 16	3
4	BM1012535	Bolt- M10 x 1.25 x 35	7
5	BM1012535	Bolt- M10 x 1.25 x 35	4
6	LYNPN10	Lynch Pin- M10	3
7	BV0103	Top Hitch Pin	1
8	CX0101	A-Frame	1
9	BM141540	Bolt- M14 x 1.5 x 40	8
10	BM141545	Bolt- M14 x 1.5 x 45	4
11	CX0315	Bearing Cap- Pinion Shaft	1
12	CX0320	Cap- Input Shaft	1
13	CX0314	Gasket- Pinion shaft	1
14	CX0318	Gasket- Input Shaft	1
15	B31310	Bearing- 31310	1
16	B30208	Bearing- 30208	1
17	CX0319	Input Shaft	1
18	B33208	Bearing- 33208	2
19	CX0316	Pinion Shaft	1
20	CX0323	Pinion Gear	1
21	SLNM4515	Spanner locking nut M45-1.5	1
22	CX0322	Ring Gear	1
23	B32012	Bearing- 32012	1
24	OS60758	Oil Seal- M60 x 75 x 8	1
25	OS406210	Oil Seal- M40 x 62 x 10	1
26	CX0311-076	Drive Shaft CXT-076	1
	CX0311-086	Drive Shaft CXT-086	1
	CX0311-095	Drive Shaft CXT-095	1
	CX0311-104	Drive Shaft CXT-104	1
	CX0311-112	Drive Shaft CXT-112	1
	CX0311-121	Drive Shaft CXT-121	1

CXT Series Rotary Tiller (Version 1)

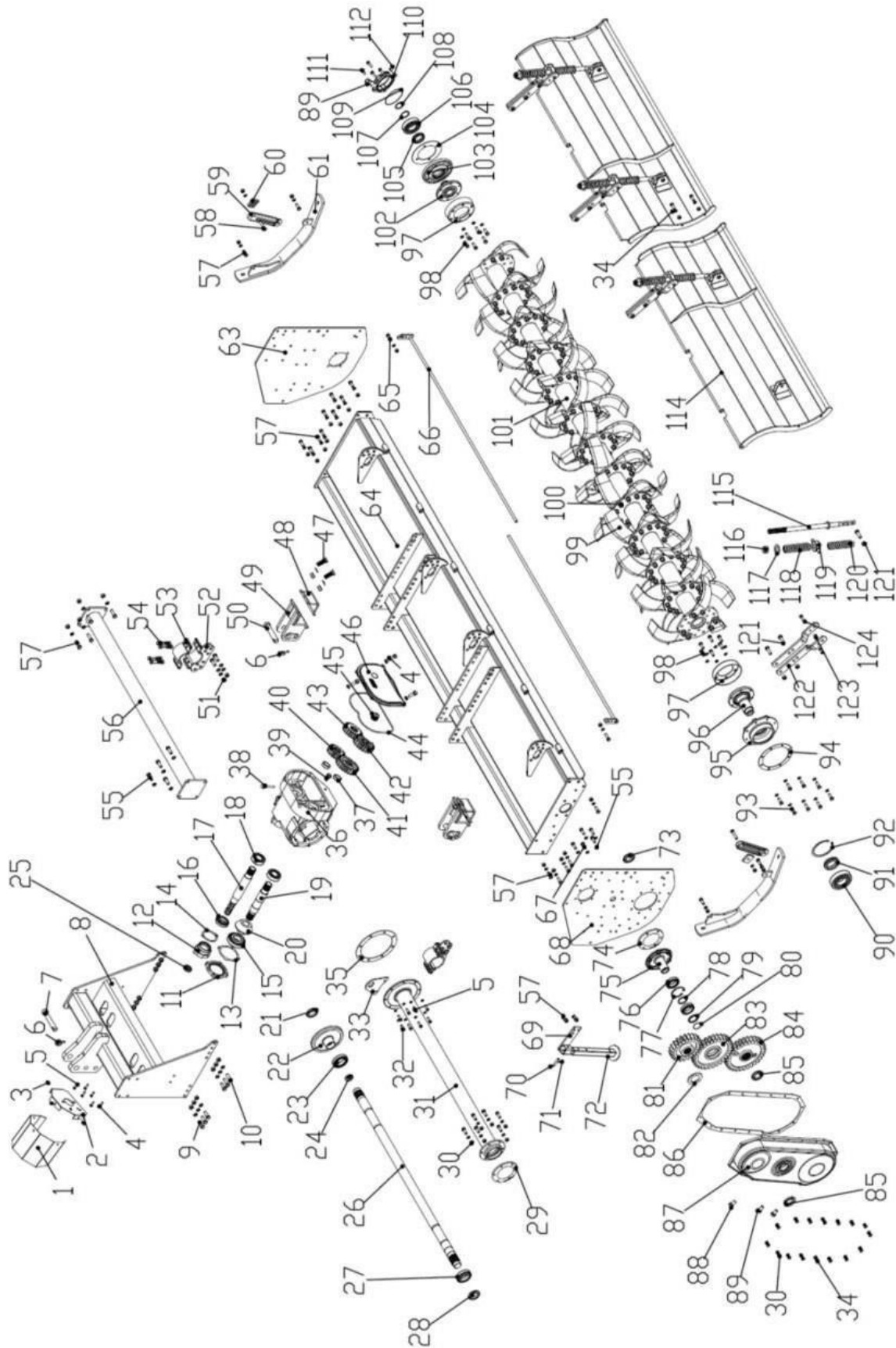

CXTGBC001 Gearbox Complete

CXT Series Rotary Tiller (Version 1)

Item	Part #	Description	Qty.
27	B32210	Bearing- 32210	1
28	SLNM4515	Spanner locking nut M45-1.5	1
29	BV0312	Gasket - Drive Tube Outer	1
30	BM1012530	Bolt- M10 x 1.25 x 30	20
31	CX0310-076	Drive Shaft Tube Housing - CXT-076	1
	CX0310-086	Drive Shaft Tube Housing - CXT-086	1
	CX0310-095	Drive Shaft Tube Housing - CXT-095	1
	CX0310-104	Drive Shaft Tube Housing - CXT-104	1
	CX0310-112	Drive Shaft Tube Housing - CXT-112	1
	CX0310-121	Drive Shaft Tube Housing - CXT-121	1
32	BM1012530	Bolt- M10 x 1.25 x 30	6
33	BV0322	Gearbox Lift Bracket	1
34	BM1012535	Bolt- M10 x 1.25 x 35	4
35	CX0309	Gasket- Drive Tube- Inner	1
36	CX0313	Gearbox Housing	1
37	CX0308	Spacer- Exchange Gear	2
38	YT10660303000	Dipstick	1
39	OP1415	Oil Plug- M14 x 1.5	1
40	CX0304	Exchange Gear- Z17	1
41	CX0303	Exchange Gear- Z23	1
42	CX0307	Exchange Gear- Z21	1
43	CX0306	Exchange Gear- Z19	1
44	CX0302	Gasket Rear Cover	1
45	CX0312	Gear Shaft	1
46	CX0305	Gearbox Cover	1
47	BM151550	Bolt- M18 x 1.5 x 50	4
48	BX0207	Hitch Block Support	2
49	CX0205	Hitch Block	2
50	CX0204	Lower Hitch Pin - Cat. 2	2
51	BM1412540	Bolt- M14 x 1.50 x 40	4
52	CX0203	Lower Tube Support	2

CXT Series Rotary Tiller (Version 1)

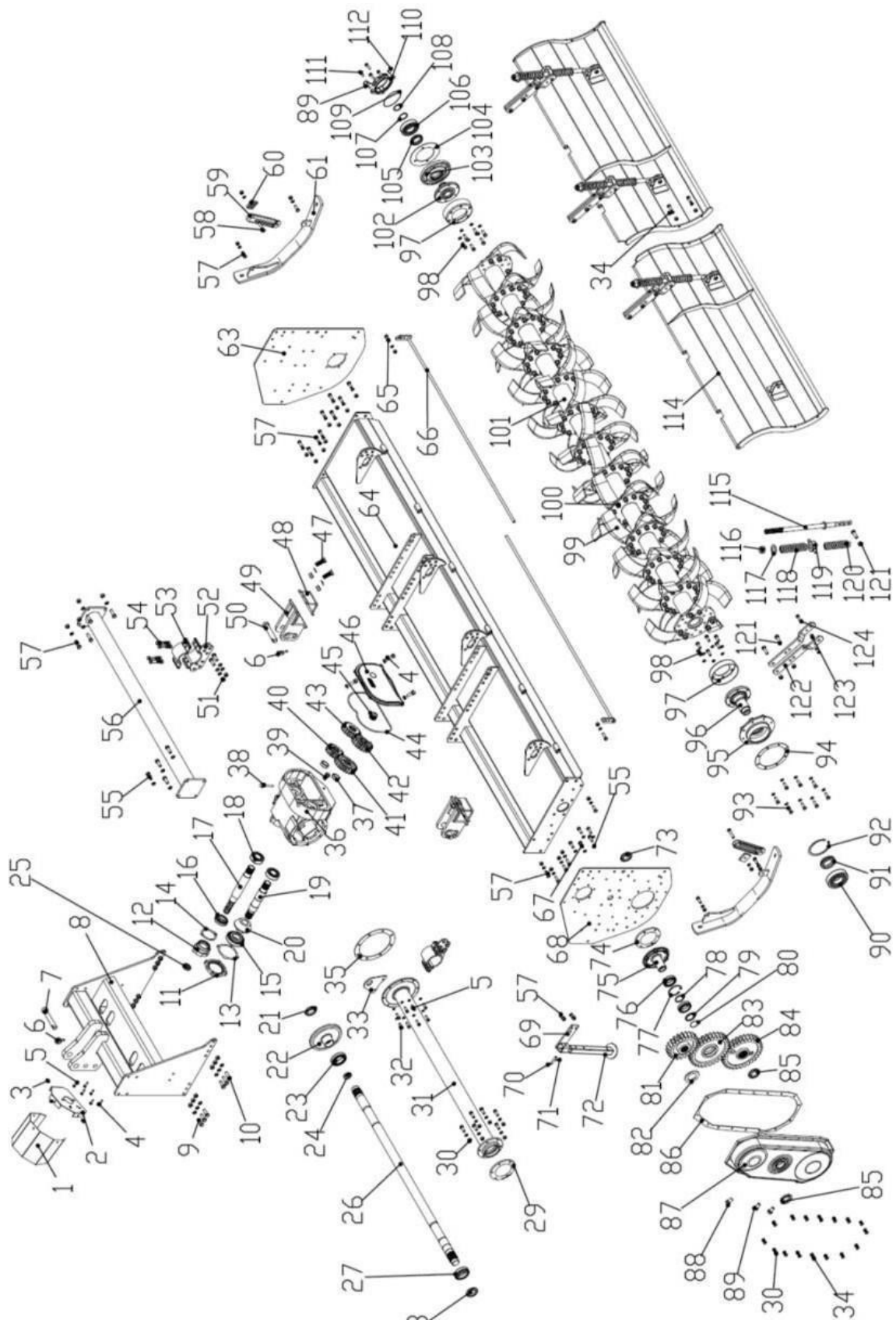

CXTGBC001 Gearbox Complete

CXT Series Rotary Tiller (Version 1)

Item	Part #	Description	Qty.
53	CX0202	Upper Tube Support	2
54	BM1212540	Bolt- M12 x 1.25 x 40	8
55	BM1212530	Bolt- M12 x 1.25 x 30	5
56	CX0301-076	Gearbox Support Tube- CXT-076	1
	CX0301-086	Gearbox Support Tube- CXT-086	1
	CX0301-095	Gearbox Support Tube- CXT-095	1
	CX0301-104	Gearbox Support Tube- CXT-104	1
	CX0301-110	Gearbox Support Tube- CXT-112	1
	CX0301-121	Gearbox Support Tube- CXT-121	1
57	BM1212535	Bolt- M12 x 1.25 x 35	24
58	BM1212560	Bolt- M12 x 1.25 x 60	2
59	BX0802	Skid Adjustment Stop	2
60	BX0801	Skid Adjustment Bracket	2
61	BV0901	Skid Weldment - Right	1
62	BV0902	Skid Weldment - Left	1
63	CX0201	Side Board-Right	1
64	CX300-076	Main Frame- CXT-076	1
	CX300-086	Main Frame- CXT-086	1
	CX300-095	Main Frame- CXT-095	1
	CX300-104	Main Frame- CXT-104	1
	CX300-112	Main Frame- CXT-112	1
	CX300-121	Main Frame- CXT-121	1
65	BM1212545	Bolt- M12 x 1.25 x 45	2
66	CX0603-076	Rod Tailgate- CXT-076	2
	CX0603-086	Rod Tailgate- CXT-086	2
	CX0603-095	Rod Tailgate- CXT-095	2
	CX0603-104	Rod Tailgate- CXT-104	2
	CX0603-112	Rod Tailgate- CXT-112	2
	CX0603-121	Rod Tailgate- CXT-121	2
67	BM1212540	Bolt- M12 x 1.25 x 40	4
68	BV0506	Side Board- Left	1

CXT Series Rotary Tiller (Version 1)

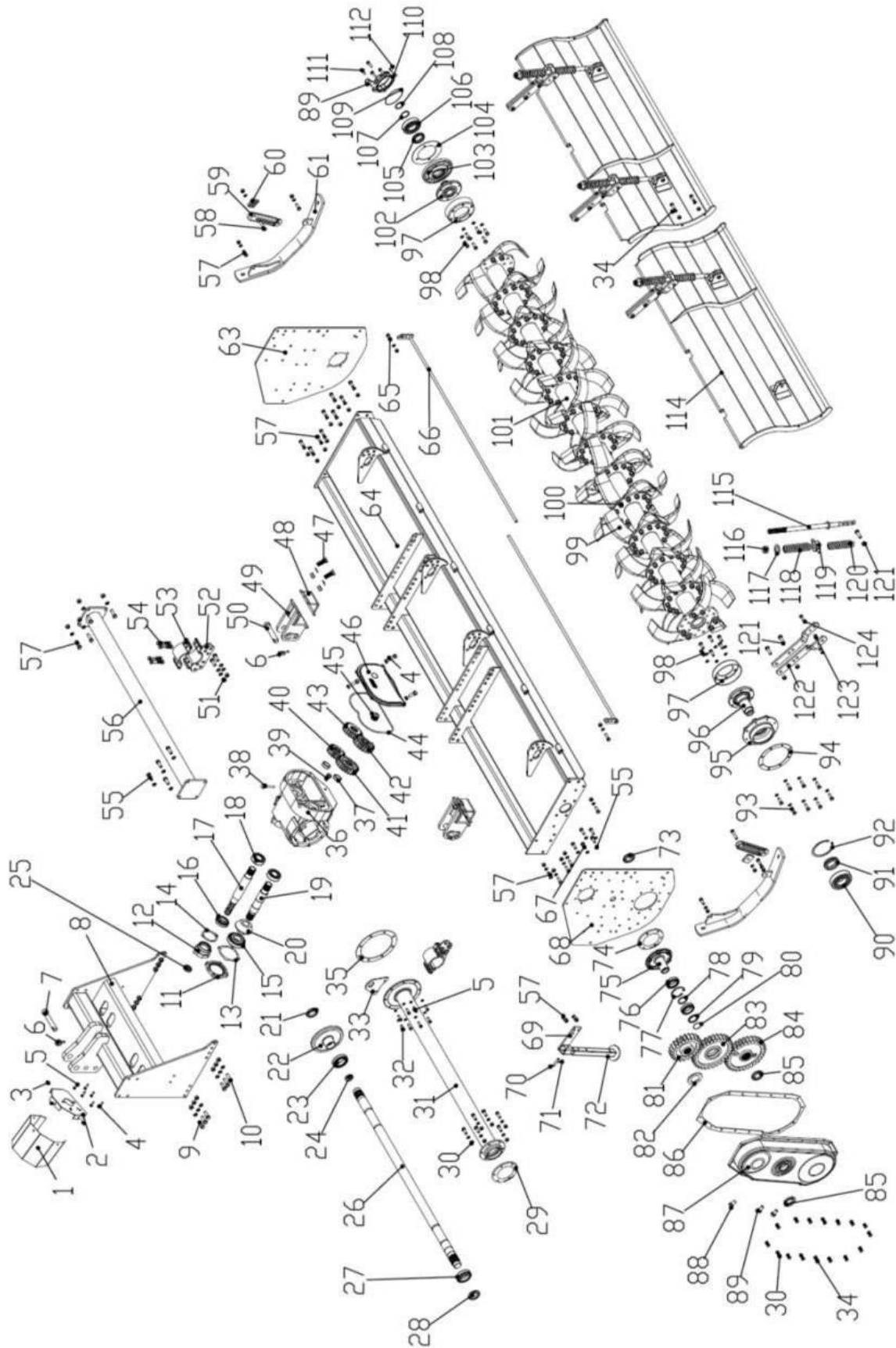

CXTGBC001 Gearbox Complete

CXT Series Rotary Tiller (Version 1)

Item	Part #	Description	Qty.
69	BV0701	Bracket- Stand	1
70	LYNPN10	Lynch Pin- M10 x 55	1
71	RC3	R-Clip- M3	1
72	BV0702	Stand	1
73	NM3515	Nut- M35 x 1.5	1
74	BV0509	Gasket- Idler Gear Hub- M170 x 140 x 1	1
75	BV0510	Idler Gear Hub	1
76	B32010	Bearing- 32010	2
77	SRI-80	Snap Ring- M80- Internal	2
78	BV0504	Spacer- M63 x 50 x 2	1
79	BV0503	Idler Gear Spacer- M63.5 x 50 x 6.5	1
80	OR50x1.8	O Ring- M50 x 1.8	1
81	BV0508	Top Gear- Z23	1
82	BV0504	Top Gear Spacer- M63 x 50 x 2	1
83	BV0502	Idler Gear- Z31	1
84	BV0501	Bottom Gear- Z31	1
85	SLNM5015	Spanner locking nut M50 x 1.5	2
86	BV0507	Gasket for Side Gear Cover	1
87	BV0500	Gear Cover	1
88	OP1615V	Breather Cap- M16 x 1.5 Vented	1
89	OP1615	Oil Plug- M16 x 1.5	3
90	B6312	Bearing- 6312	1
91	OSHF0720A	Oil Seal- HF0720A	1
92	SRI-130	Snap Ring- M130- Internal	1
93	BM1012525	Bolt- M10 x 1.25 x 25	8
94	CX0511	Gasket for Left Side of Rotor	1
95	CX0401	Bearing Support	1
96	BV0402	Rotor Support Shaft - Left	1
97	BV0403	Rotor Shield	2
98	BM1212535	Bolt- M12 x 1.25 x 35	12

CXT Series Rotary Tiller (Version 1)

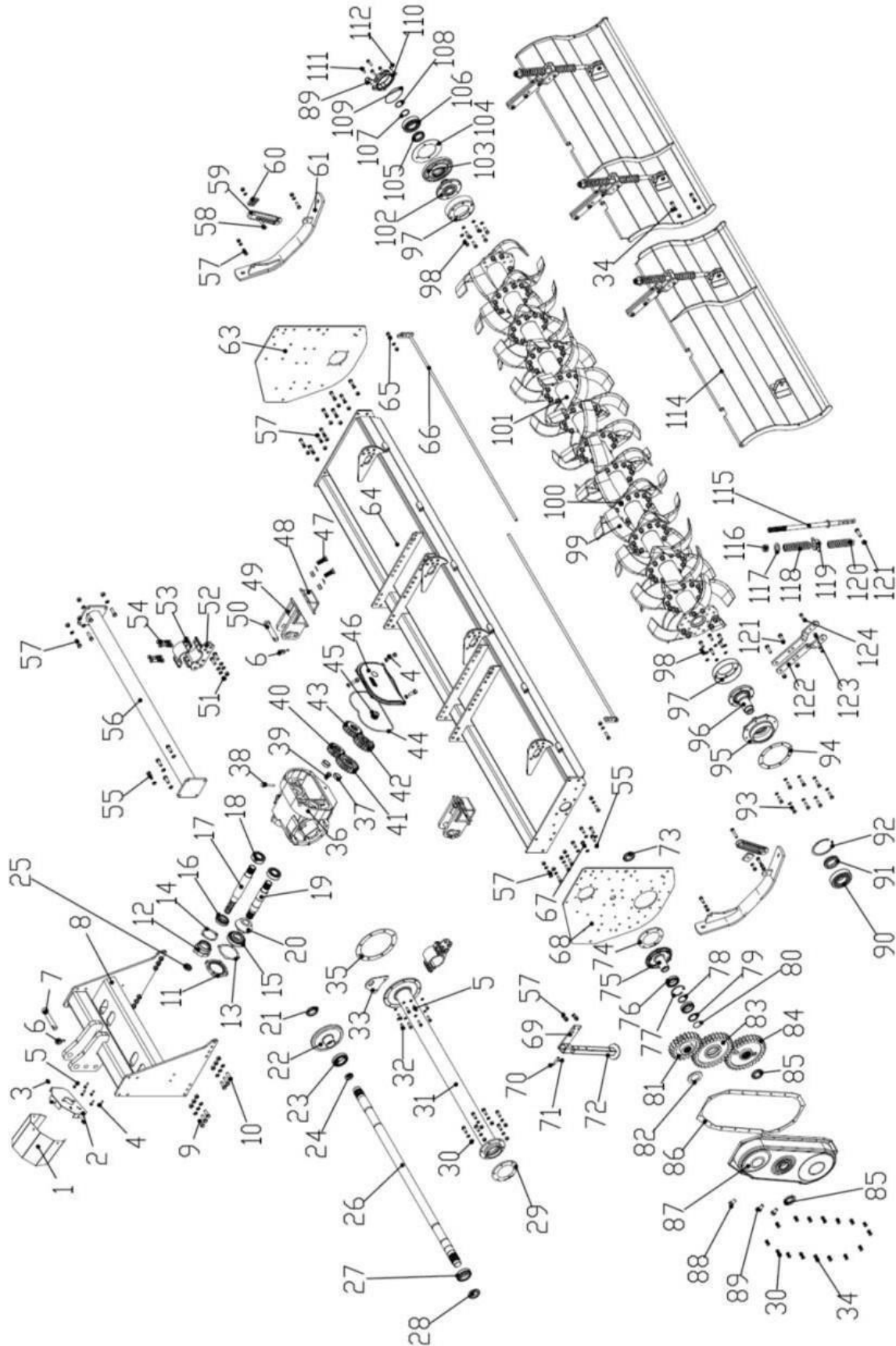

CXTGBC001 Gearbox Complete

CXT Series Rotary Tiller (Version 1)

Item	Part #	Description	Qty.
99	BV0210R	Tiller Tine- Right (CXT-076)	21
	BV0210L	Tiller Tine- Left (CXT-076)	21
	BV0210R	Tiller Tine- Right (CXT-086)	24
	BV0210L	Tiller Tine- Left (CXT-086)	24
	BV0210R	Tiller Tine- Right (CXT-095)	27
	BV0210L	Tiller Tine- Left (CXT-095)	27
	BV0210R	Tiller Tine- Right (CXT-104)	30
	BV0210L	Tiller Tine- Left (CXT-104)	30
	BV0210R	Tiller Tine- Right (CXT-112)	33
	BV0210L	Tiller Tine- Left (CXT-112)	33
	BV0210R	Tiller Tine- Right (CXT-121)	36
	BV0210L	Tiller Tine- Left (CXT-121)	36
100	BM141540	Bolt- M14 x 1.5 x 40	-
	LW14	Washer, lock M14	-
	NM1415	Nut, HH M14-1.5	-
101	CX0401-076	Rotor Shaft- CXT-076	1
	CX0401-086	Rotor Shaft- CXT-086	1
	CX0401-095	Rotor Shaft- CXT-095	1
	CX0401-104	Rotor Shaft- CXT-104	1
	CX0401-112	Rotor Shaft- CXT-112	1
101	CX0401-121	Rotor Shaft- CXT-121	1
102	BV0405	Rotor Support Shaft- Right	1
103	BV0406	Bearing Support	1
104	BV0407	Gasket- M192 x 118 x 1	1
105	OSHF0610	Floating Oil Seal- HF0610	1
106	B6310	Bearing- 6310	1
107	BV0408	Spacer- Rotor Support- Right- M63 x 50 x 4	1
108	SRE-50	Snap Ring- External- M50	1
109	OR118x3.55	O-Ring- M118 x 3.55	1
110	BV0409	Rotor Cap	1
111	BM1212540	Bolt- M12 x 1.25 x 40	4
112	OP12125	Oil Plug- M12 x 1.25	1

CXT Series Rotary Tiller (Version 1)

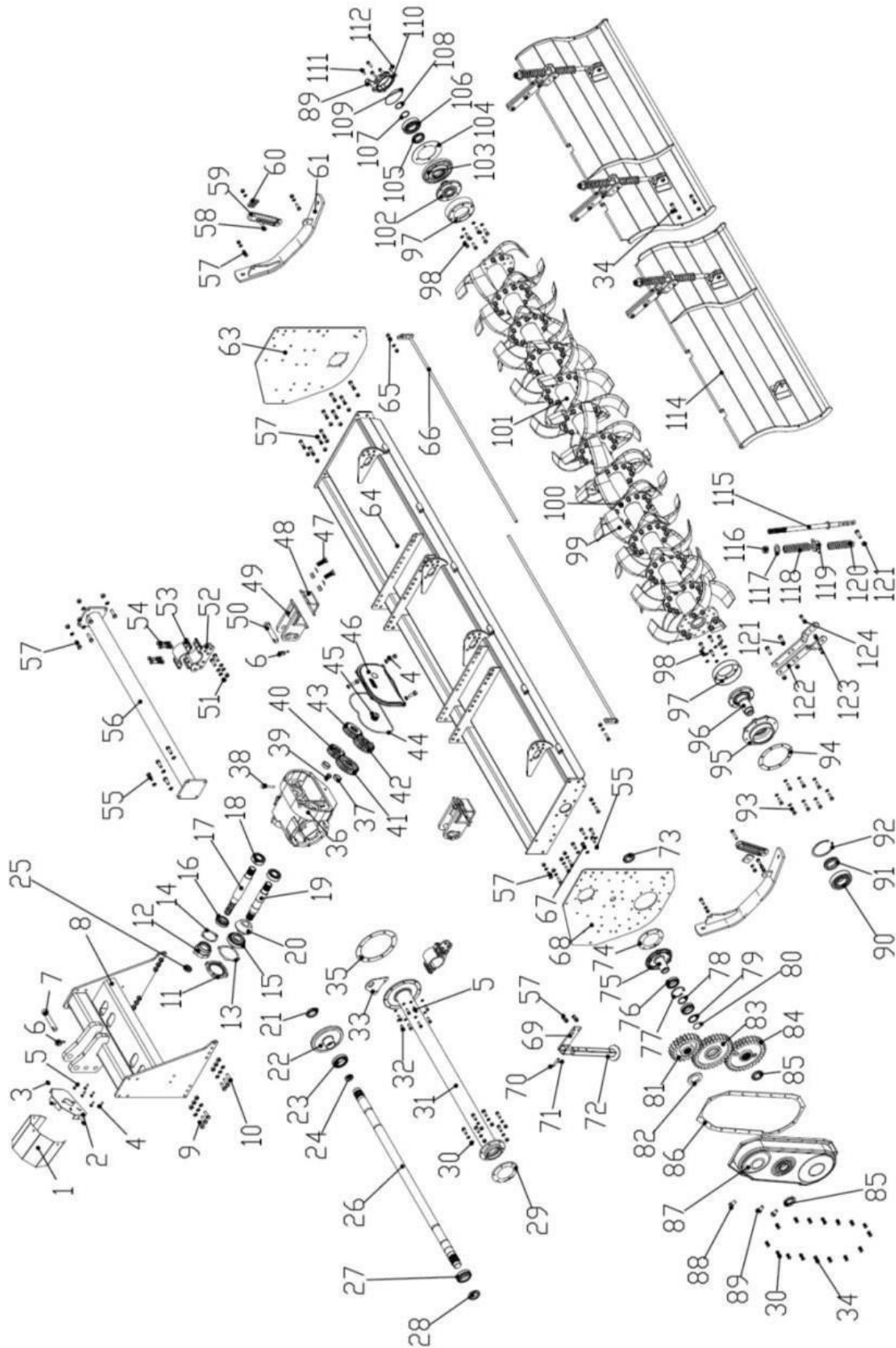

CXTGBC001 Gearbox Complete

CXT Series Rotary Tiller (Version 1)

Item	Part #	Description	Qty.
114	CX0601-076R	Tailgate- Right- CXT-076	1
	CX0601-076L	Tailgate- Left- CXT-076	1
	CX0601-086R	Tailgate- Right- CXT-086	1
	CX0601-086L	Tailgate- Left- CXT-086	1
	CX0601-095R	Tailgate- Right- CXT-095	1
	CX0601-095L	Tailgate- Left- CXT-095	1
	CX0601-104R	Tailgate- Right- CXT-104	1
	CX0601-104L	Tailgate- Left- CXT-104	1
	CX0601-112R	Tailgate- Right- CXT-112	1
	CX0601-112L	Tailgate- Left- CXT-112	1
	CX0601-121R	Tailgate- Right- CXT-121	1
	CX0601-121L	Tailgate- Left- CXT-121	1
115	BV0605	Rod- Tailgate	2
116	LNM243	Self-locking Nut- M24 x 3.0	4
117	FW24	Flat Washer- M24	4
118	BV0601	Upper Tailgate Spring- M175	4
119	BV0606	Spring Bushing	4
120	BV0609	Lower Tailgate Spring- M184	4
121	BM141545	Bolt- M14 x1.5 x 45	12
122	BV0607	Tailgate Spring Bracket-	8
123	BV0604	Spacer for Tailgate Brackets- M26 x 10.5 x 10	4
124	BM1012545	Bolt- M10 x 1.25 x 45	4
	CXTGBC001	Gearbox Complete- with exchange gears	
	147130	Complete PTO - Series 80 - M220 Slip Clutch	1
	180-510-60	Friction Disc – 6.30” OD	1

CXT Series Rotary Tiller (Version 2)

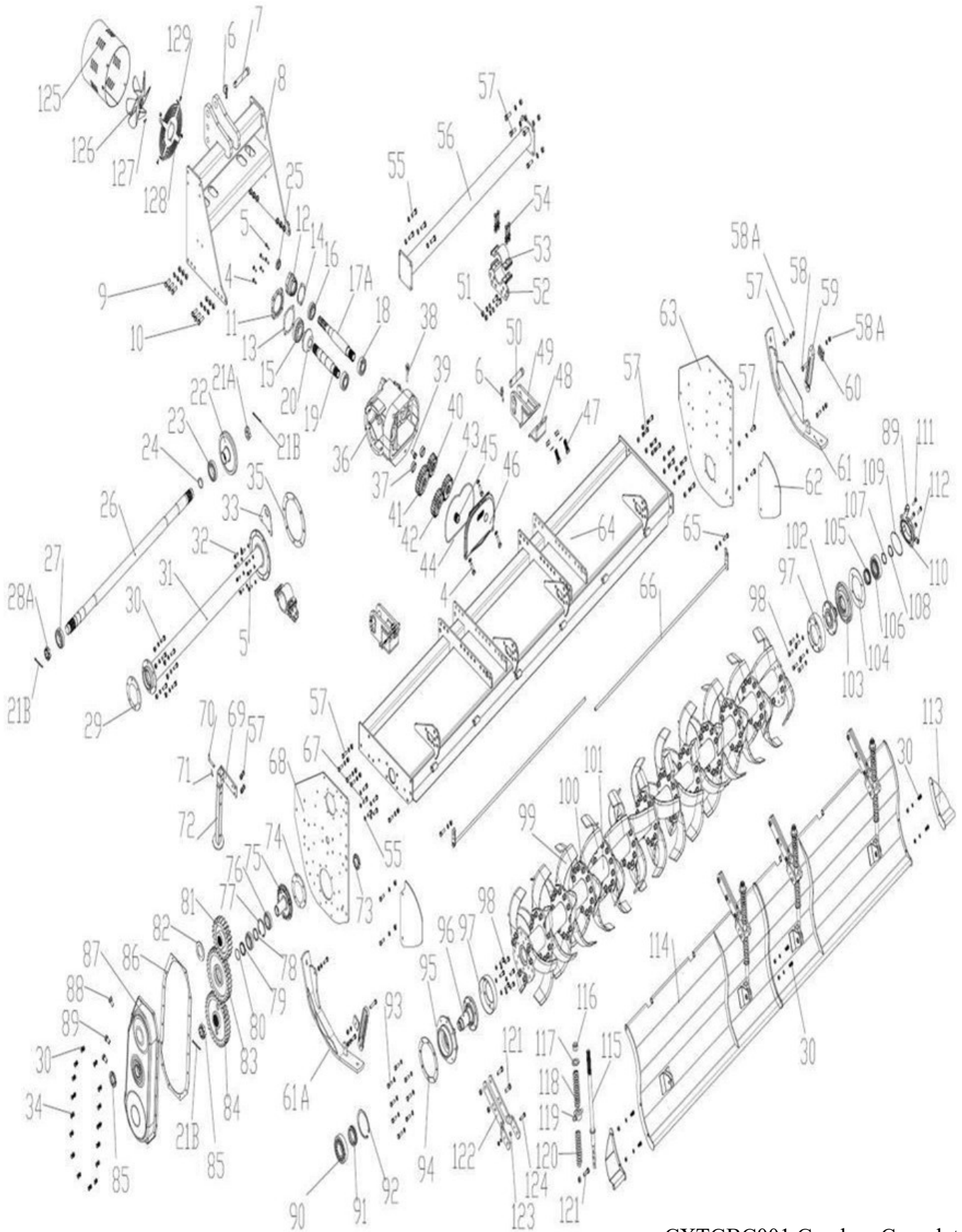

CXTGBC001 Gearbox Complete

CXT Series Rotary Tiller (Version 2)

Item	Part #	Description	Qty.
1	N/A		
2	N/A		
3	N/A		
4	BM1012535	Bolt- M10 x 1.25 x 35	7
5	BM1012535	Bolt- M10 x 1.25 x 35	4
6	LYNPN10	Lynch Pin- M10	3
7	BV0103	Top Hitch Pin	1
8	CX0101	A-Frame	1
9	BM141540	Bolt- M14 x 1.5 x 40	8
10	BM141545	Bolt- M14 x 1.5 x 45	4
11	CX0315	Pinion Shaft Bearing Cap	1
12	CX0320	Input Shaft Cap	1
13	CX0314	Pinion Shaft Gasket	1
14	CX0318	Input Shaft Gasket	1
15	B31310	Bearing- 31310 (HRB)	1
16	B31208	Bearing- 30208 (HRB)	1
17	CX0319A	Input Shaft	1
18	B33208	Bearing- 33208 (HRB)	2
19	CX0316	Pinion Shaft	1
20	CX0323	Pinion Gear	1
21	CP5x80	Cotter Pin- M5 x 80	
22	CX0322	Ring Gear	1
23	B32012	Bearing- 32012 (HRB)	1
24	OS607508	Oil Seal- M60 x 75 x 8	1
25	OS406210	Oil Seal- M40 x 62 x 10	1
26	CX0311-086	Drive Shaft- CXT-086	1
	CX0311-095	Drive Shaft- CXT-095	1
	CX0311-104	Drive Shaft- CXT-104	1
	CX0311-112	Drive Shaft- CXT-112	1
	CX0311-121	Drive Shaft- CXT-121	1
27	B32210	Bearing- 32210 (HRB)	1

CXT Series Rotary Tiller (Version 2)

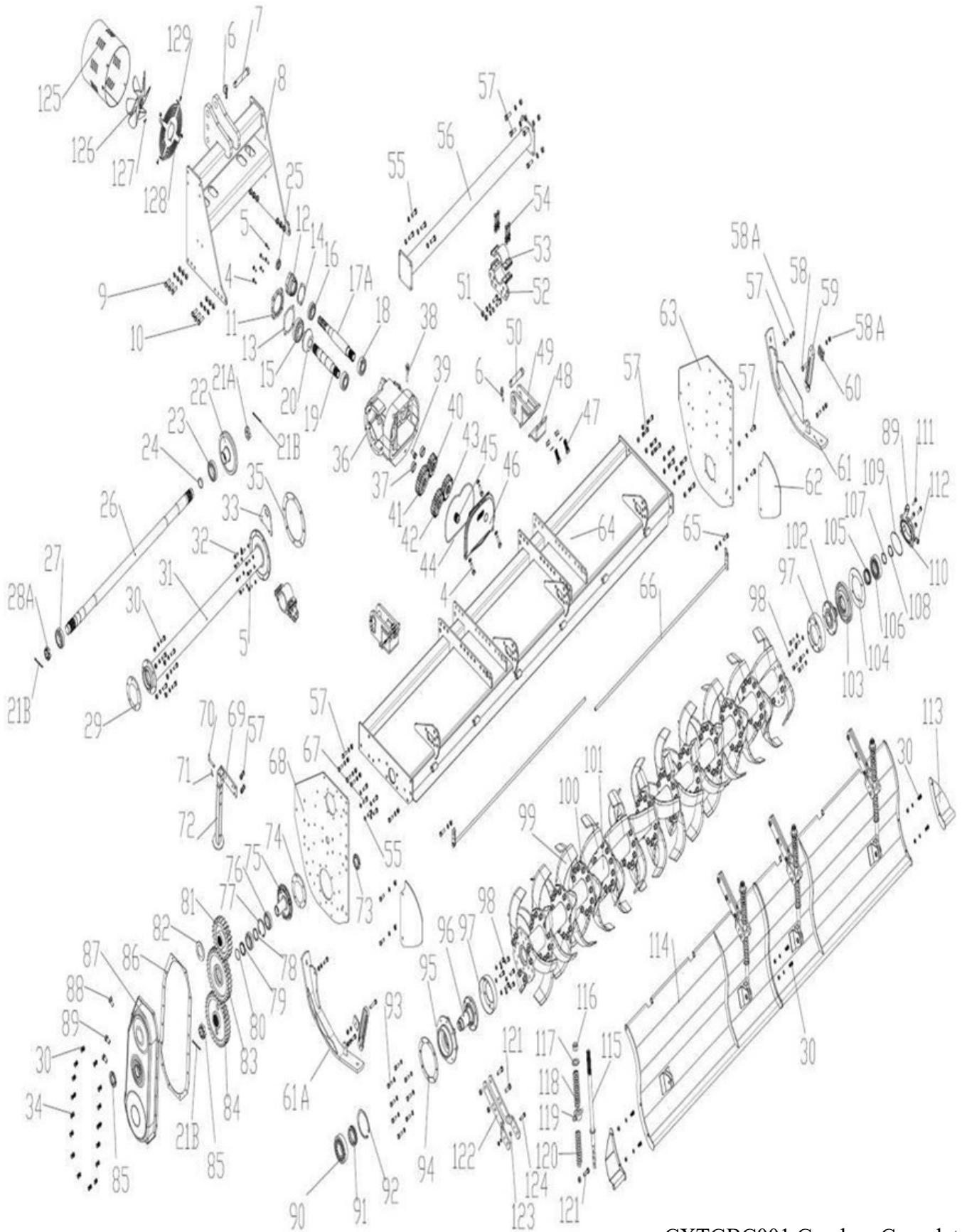

CXTGBC001 Gearbox Complete

CXT Series Rotary Tiller (Version 2)

Item	Part #	Description	Qty.
28	SLNM4515	Spanner locking nut M45-1.5	1
29	BV0312	Gasket- Drive Tube Outer	
30	BM1012530	Bolt- M10 x 1.25 x 30	20
31	CX0310-086	Gearbox Shaft Tube Housing- CXT-086	1
	CX0310-095	Gearbox Shaft Tube Housing- CXT-095	1
	CX0310-104	Gearbox Shaft Tube Housing- CXT-104	1
	CX0310-112	Gearbox Shaft Tube Housing- CXT-112	1
	CX0310-121	Gearbox Shaft Tube Housing- CXT-121	1
32	BM1012530	Bolt- M10 x 1.25 x 30	6
33	BV0322	Gearbox Lift Bracket	1
34	BM1012530	Bolt- M10 x 1.25 x 30	20
35	CX0309	Gasket- Drive Tube- Inner	1
36	CX0313	Gearbox Housing	1
37	CX0308	Spacer (Exchange Gear)	2
38	YT10660303000	Dip Stick	1
39	OP1415	Oil Plug- M14X1.5	1
40	CX0304	Exchange Gear- Z17	1
41	CX0303	Exchange Gear- Z23	1
42	CX0307	Exchange Gear- Z21	1
43	CX0306	Exchange Gear- Z19	1
44	CX0302	Gasket Rear Cover	1
45	CX0312	Gear Shaft	1
46	CX0305	Gearbox Cover	1
47	BM181550	Bolt- M18 x 1.5 x 50	4
48	BX0207	Hitch Block Support	2
49	CX0205	Hitch Block	2
50	CX0204	Lower Hitch Pin- Cat.2	2
51	BM141540	Bolt- M14 x 1.5 x 40	4
52	CX0203	Tube Support-Lower	2
53	CX0202	Tube Support-Upper	2
54	BM1212540	Bolt- M12 x 1.25 x 40	8

CXT Series Rotary Tiller (Version 2)

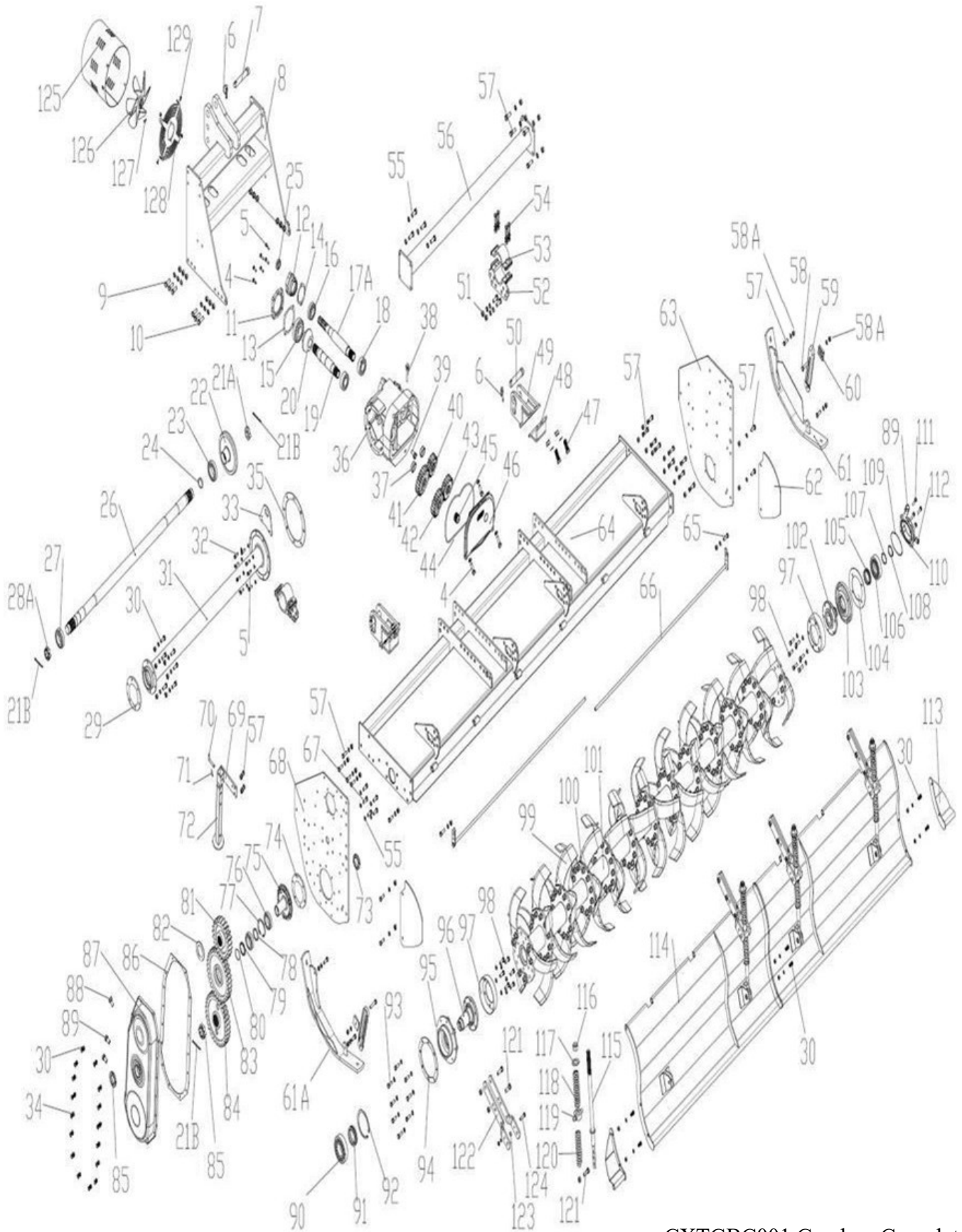

CXTGBC001 Gearbox Complete

CXT Series Rotary Tiller (Version 2)

Item	Part #	Description	Qty.
55	BM1212530	Bolt- M12 x 1.25 x 30	5
56	CX0301-086	Gearbox Support Tube- CXT-086	1
	CX0301-095	Gearbox Support Tube- CXT-095	1
	CX0301-104	Gearbox Support Tube- CXT-104	1
	CX0301-112	Gearbox Support Tube- CXT-112	1
	CX0301-121	Gearbox Support Tube- CXT-121	1
57	BM1212535	Bolt- M12 x 1.25 x 35	24
58	BM1212560	Bolt- M12 x 1.25 x 60	2
58A	LNM12125	Self locking nut M12-1.25	26
59	BV0801	Skid Adjustment Bracket	2
60	BV0802	Skid Adjustment Stop	2
61	BV0902	Skid Weldment- Left	1
61A	BV0901	Skid Weldment- Right	1
62	BV0509	Gasket- M170 x 140 x 1	2
63	CX0201	Side Board- Right	1
64	CX2050201	Main Frame- CXT-086	1
	CX2300201	Main Frame- CXT-095	1
	CX2600201	Main Frame- CXT-104	1
	CX2800202	Main Frame- CXT-112	1
	CX3000201	Main Frame- CXT-121	1
65	BM1212545	Bolt- M12 x 1.25 x 45	2
66	CX0603-086	Rod- Tail Gate - CXT-086	2
	CX0603-095	Rod- Tail Gate - CXT-095	2
	CX0603-104	Rod- Tail Gate - CXT-104	2
	CX0603-112	Rod- Tail Gate - CXT-112	2
	CX0603-121	Rod- Tail Gate - CXT-121	2
67	BM1212540	Bolt- M12 x 1.25 x 40	4
68	BV0506	Side Board- Left	1
69	BV0701	Bracket- Stand	1
70	BV0703	Lynch Pin- M10 x 55	1
71	RC3000	R Clip- M3	1
72	BV0702	Stand	1
73	SNM3515	Spanner Nut- M35 x 1.5	1

CXT Series Rotary Tiller (Version 2)

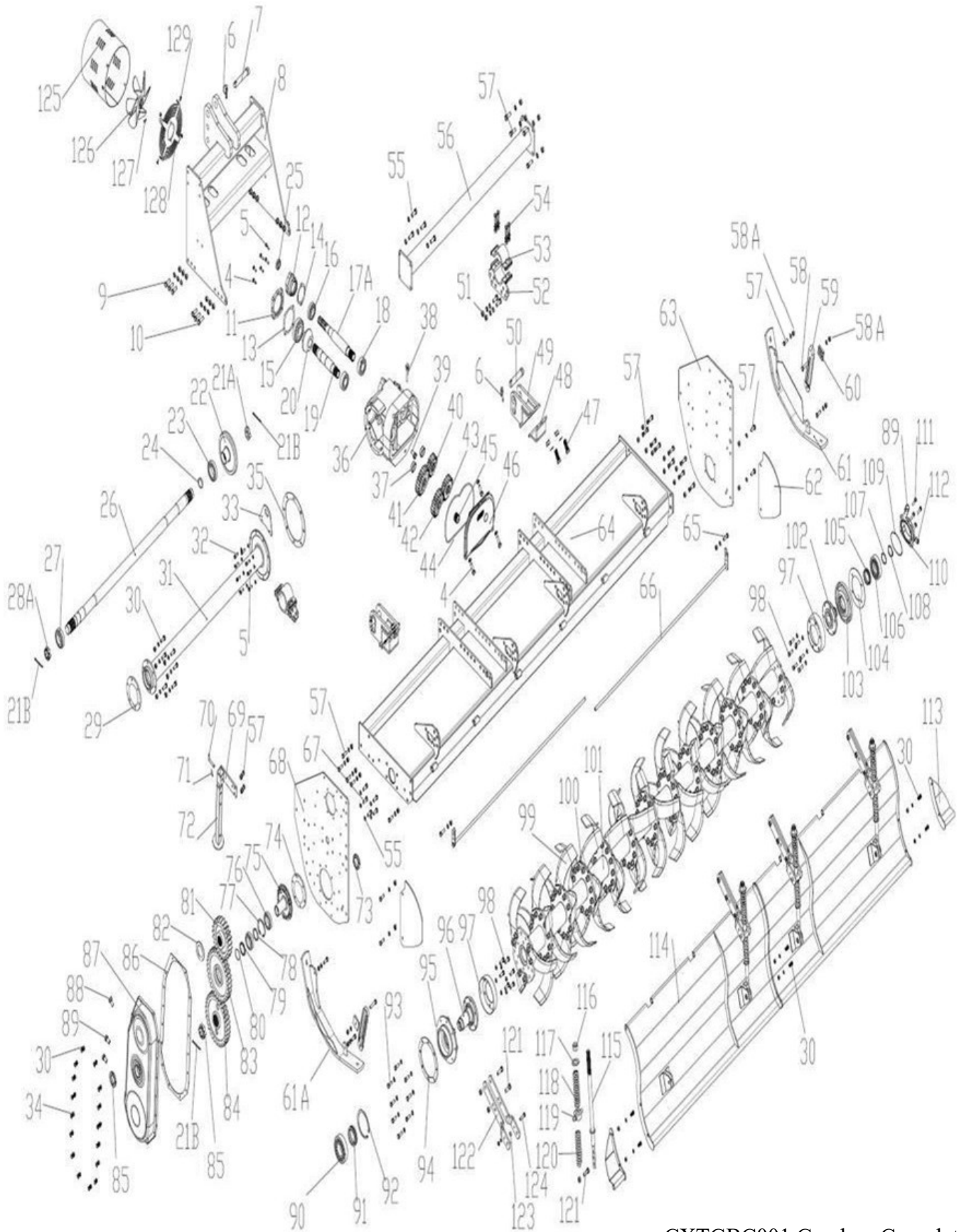

CXTGBC001 Gearbox Complete

CXT Series Rotary Tiller (Version 2)

Item	Part #	Description	Qty.
74	BV0509	Gasket- Idler Gear hub	1
75	BV0510	Idler Gear Hub	1
76	B32010	Bearing- 32010	2
77	SRI-80	Snap Ring- Internal- M80	2
78	BV0504	Spacer- M63 x 50 x 2	1
79	BV0503	Spacer- Idler Gear- M63.5 x 50 x 6.5	1
80	OR5018	O-Ring- M50 x 1.8	1
81	BV0505	Gear- Top Z23	1
82	BV0506	Spacer- Top Gear- M63 x 50 x 2	1
83	BV0502	Gear- Idler Z31	1
84	BV0501	Gear- Bottom Z31	1
85	SLNM5015	Spanner locking nut M50 x 1.5	2
86	BV0507	Gasket - Gear Cover	1
87	BV0501	Gear Cover	1
88	OP1615V	Breather Cap- M16 x 1.5	1
89	OP1615	Oil Plug- M16 x 1.5	3
90	B6312	Bearing- 6312	1
91	OSHF0720A	Oil Seal- HF0720A	1
92	SRI130	Snap Ring- Internal- M130	1
93	BM1012525	Bolt- M10 x 1.25 x 25	8
94	CX0511	Gasket - Left Rotor	1
95	CX0401	Bearing support	1
96	BV0402	Rotor Support Shaft - Left	1
97	BV0403	Rotor Shield	2
98	BM1212535	Bolt- M12 x 1.25 x 35	12

CXT Series Rotary Tiller (Version 2)

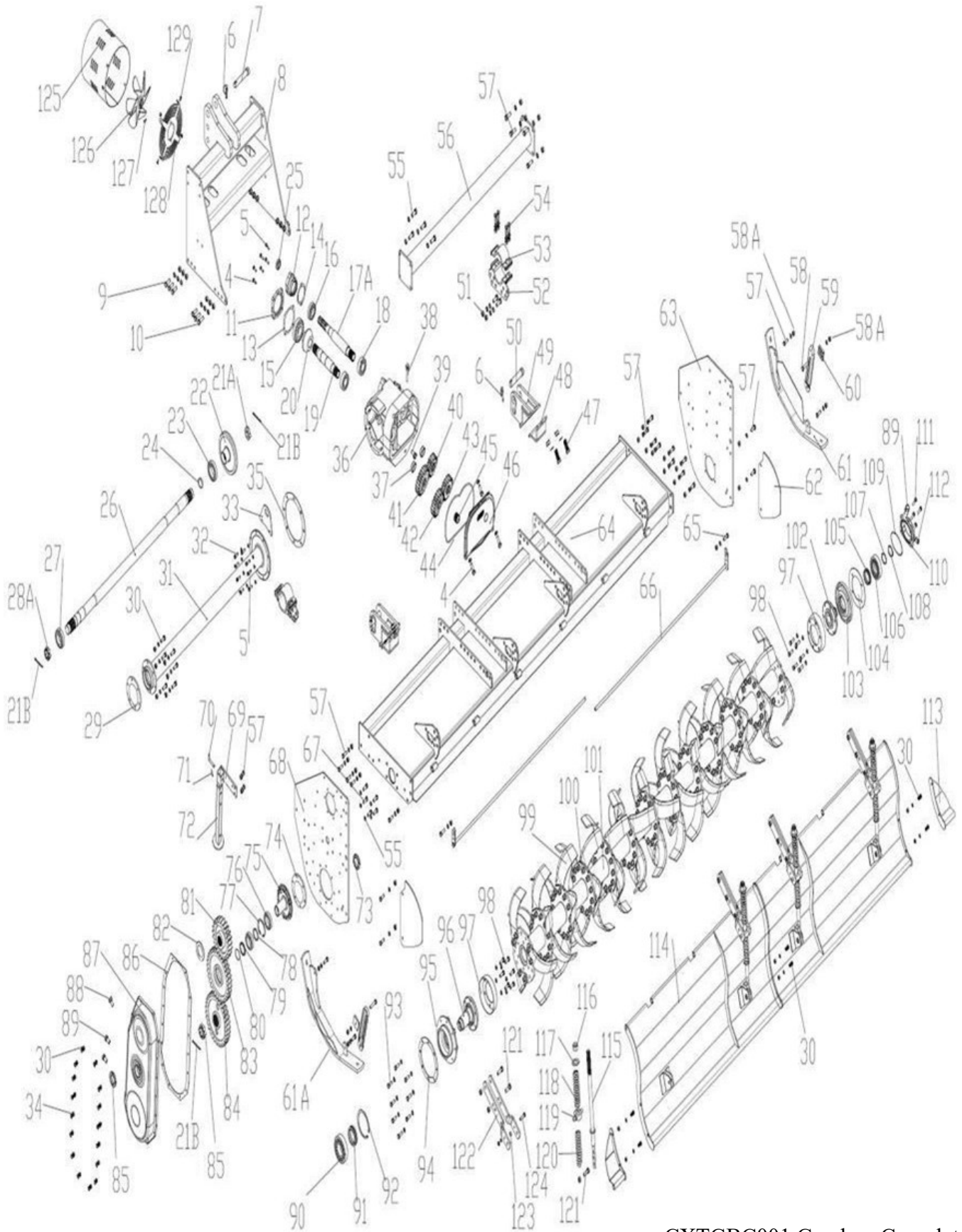

CXTGBC001 Gearbox Complete

CXT Series Rotary Tiller (Version 2)

Item	Part #	Description	Qty.
99	BV0210R	Tiller Tine- Right (CXT-086)	24
	BV0210L	Tiller Tine- Left (CXT-086)	24
	BV0210R	Tiller Tine- Right (CXT-095)	27
	BV0210L	Tiller Tine- Left (CXT-095)	27
	BV0210R	Tiller Tine- Right (CXT-104)	30
	BV0210L	Tiller Tine- Left (CXT-104)	30
	BV0210R	Tiller Tine- Right (CXT-112)	33
	BV0210L	Tiller Tine- Left (CXT-112)	33
	BV0210R	Tiller Tine- Right (CXT-121)	36
	BV0210L	Tiller Tine- Left (CXT-121)	36
100	BM141540	Bolt- M14 x 1.5 x 40	156
	LW14	Washer, lock M14	156
	SFLN1415	Nut self locking Stover wFlange M14-1.5	156
101	CX0401-086	Rotor Shaft- CXT-086	1
	CX0401-095	Rotor Shaft- CXT- 095	1
	CX0401-104	Rotor Shaft- CXT-104	1
	CX0401-112	Rotor Shaft- CXT-112	1
	CX0401-121	Rotor Shaft- CXT-121	1
102	BV0405	Rotor Support Shaft- Right	1
103	BV0406	Support Bearing- Rotor- Right	1
104	BV0407	Gasket- Rotor- Right- M192 x 118 x 1	1
105	OSHF0610	Oil Seal- HF0610	1
106	B6310	Bearing- 6310 (HRB)	1
107	BV0408	Spacer- Rotor Support- Right- M63 x 50 x 4	1
108	SRE-50	Snap Ring- External- M50	1
109	OR118355	Oil Ring- M118 x 3.55	1
110	BV0409	Rotor Cap	1
111	BM1212540	Bolt- M12 x 1.25 x 40	4
112	OP12125	Oil Plug- M12 x 1.5	1
113A	CX0113A	Tailgate Extension- Left	1
113B	CX0113B	Tailgate Extension- Right	1

CXT Series Rotary Tiller (Version 2)

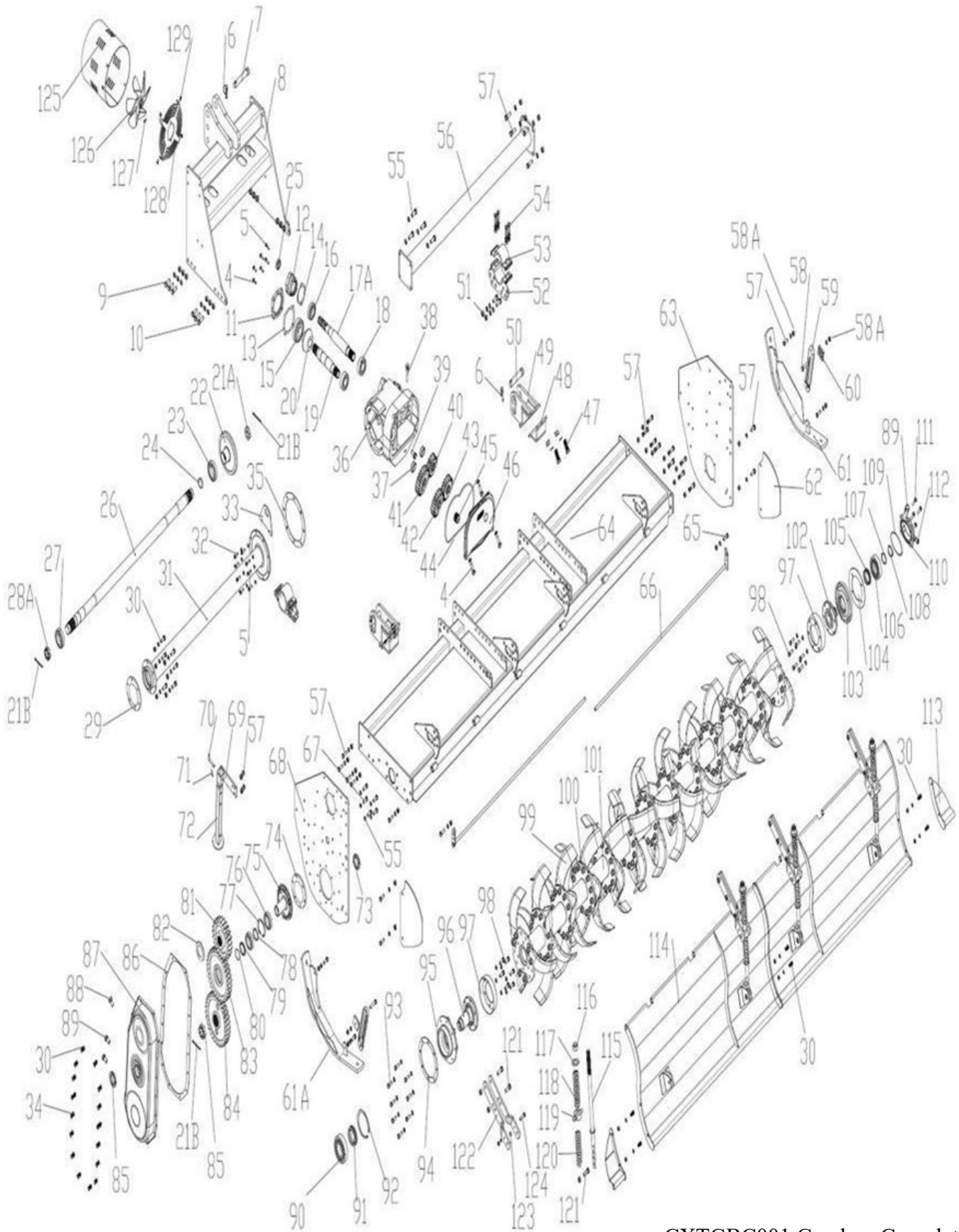

CXTGBC001 Gearbox Complete

CXT Series Rotary Tiller (Version 2)

Item	Part #	Description	Qty.
114	CX0601-086	Tailgate- CXT-086	1
	CX0601-095	Tailgate- CXT-095	1
	CX0601-104	Tailgate- CXT-104	1
	CX0601-112	Tailgate- CXT-112	1
	CX0601-121	Tailgate- CXT-121	1
115	BV0601	Rod- Tailgate	4
116	LNM2430	Self-Locking Nut- M24 x 3	4
117	FW24	Washer- M24	4
118	BV0601	Upper Spring- Tailgate	4
119	BV0606	Spacer- Tailgate	4
120	BV0602	Lower Spring- Tailgate	4
121	BM141545	Bolt- M14 x 1.5 x 45	12
122	BV0607	Bracket- Tailgate Spring	8
123	BV0604	Bolt Spacer- Tailgate	4
124	BM1012545	Bolt- M10 x 1.25 x 45	4
125	CXTCFS	Fan Shroud	1
126	CXTCF-01	Fan	1
127	ABM061016	Allen Bolt- M6 X 1.0 X 16	1
128	CXTCF-02	Fan Protection Screen	1
129	BM061016	Bolt- M6 x 1.0 x 16	4
	CXTGBC001	Gearbox Complete- with exchange gears	

PTO Shaft - BXV, CXT

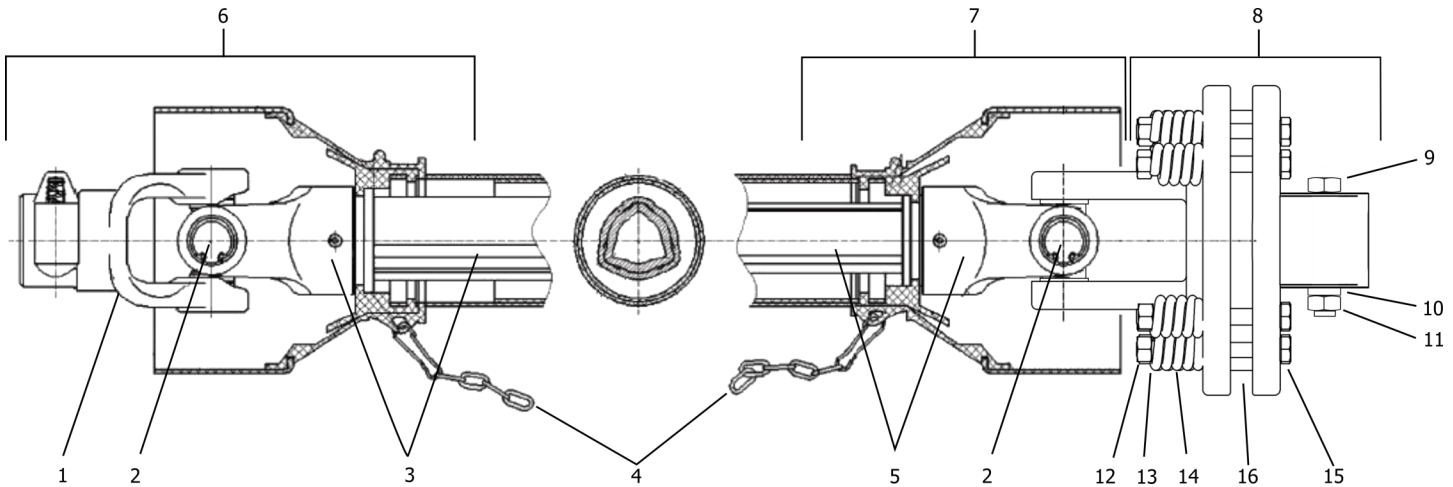

Item	Part #	Description	Qty.
1	DP1075-80	PTO Yoke - Series 80	1
2	DP1076-80	Cross and Bearings - Series 80	2
3	DP1079-80	Female Yoke and Tube (tractor end) - Series 80	1
4	5SB3007	Safety chain	2
5	DP1078-80	Male Yoke and Tube (implement end) - Series 80	1
6	DP1074F-80	Complete Female End PTO Shielding (tractor end)	1
7	DP1074M-80	Complete Male End PTO Shielding (implement end)	1
8	DP1098-80	Slip clutch complete 220mm clutch	1
9	BM1217565	Bolt HH M12-1.75x65 (8.8)	2
10	LNM12175	Nut lock M12-1.75	2
11	FW12	Washer flat M12	2
12	LNM1015	Nut lock M10-1.50	8
13	FW10	Washer flat M10	8
14	1215012-30	Spring - slip clutch	8
15	BM1015110	Bolt HH 10-1.50x110 (8.8)	8
16	180-510-80	Friction disc - 160mm x 98mm	4
-	147130	Complete PTO - Series 80 - 220mm Slip Clutch	1

Model Modifications - CXT

<u>Version 1</u>		<u>Version 2</u>	
Model #	Serial #	Model #	Serial #
CXT-076	Up to 5004	CXT-076	5005 & after
CXT-086	Up to 20002	CXT-086	20003 & after
CXT-095	Up to 23003	CXT-095	23004 & after
CXT-104	Up to 26001	CXT-104	26002 & after
CXT-112	Up to 28001	CXT-112	28002 & after
CXT-121	Up to 30005	CXT-121	30006 & after

Decals

⚠ WARNING

To prevent serious injury or death:
 si no lee ingles, pida ayuda a alguien que si lo lea para que le traduzca las medidas de seguridad

- Read and understand Operator's Manual before using. Review annually.
- Do not permit riders on the tractor including children.
- Do not allow children to operate unit.
- Operate only with guards installed and in good working condition.
- Keep away from moving parts.
- Operate only with tractor equipped with ROPS and seatbelts.
- Use extra care when operating on rough terrain or when rocks or debris are present.
- Do not operate in a raised position.
- Stop engine, lower unit, set brake and wait for all moving parts to stop before dismounting.
- Support unit securely before working beneath it.
- Transport with clean reflectors, SMV and working lights as required by Federal, State and local laws.
- Keep yourself, others and clothing away from rotating PTO.
- Operate only at a safe distance from bystanders.
- Do not stand between tractor and unit.
- Be careful on uneven terrain. Decrease speed when turning.
- Locate underground utility lines before operating unit.
- Do not exceed a safe transport speed.

RT1004D

1

⚠ WARNING
Cancer and Reproductive Harm
www.P65Warnings.ca.gov D960

2

⚠ WARNING



TO PREVENT SERIOUS INJURY OR DEATH

- Keep hands and body out of hitch area when attaching mower to tractor.
- Keep body clear of crush point between tractor and mower.

RT1005

3

⚠ DANGER



ROTATING TINES HAZARD

- Keep away from rotating tines.
- Rotating tines may cause serious injury or death.

RT1006

4

⚠ DANGER



**ROTATING DRIVELINE HAZARD
 KEEP AWAY**

To prevent serious injury or death from rotating driveline:

- Keep all guards in place when operating.
- Operate only at 540 RPM.
- Keep hands, feet, clothing and hair away from moving parts.
- Do not operate without driveline securely attached at both ends.
- Do not operate without driveline shield that turns freely on driveline.

RT1007

5

⚠ DANGER

FAILING TO FOLLOW SAFETY MESSAGES AND OPERATING INSTRUCTIONS CAN CAUSE SERIOUS BODILY INJURY OR EVEN DEATH TO OPERATOR AND OTHERS IN THE AREA.

<p>1. READ MANUAL.</p> 	<p>2. SEAT BELTS, ROPS, NO RIDERS!</p> 	<p>3. SAFETY SHOES, HARD HAT, SAFETY GLASSES.</p> 	<p>4. SUPPORT MACHINE TO AVOID CRUSHING.</p> 
--	---	---	--

1. Read operator's manual carefully and pay attention to safety decals for tractor and tiller thoroughly to avoid misuse, abuse and accidents. Practice before operating.
2. Operate only with ROPS and fastened seat belt to avoid injury and possible crushing death from overturning. Do not allow riders on tractor or tiller. Falling off can cause serious injury or death by being run over by tractor or tiller or by being cut by the rotating tiller blades. Do not allow children on or near tiller or tractor.
3. To avoid injury from falling objects wear hard hat, safety glasses and shoes.
4. Block up or support machine securely before putting hands or feet under, or working underneath lifted parts to avoid crushing injury or even death from sudden, inadvertent dropping. Make sure area is clear before lowering.
5. Before transporting, put lift lever in Lift (Detent) position and follow all traffic codes. Slow down at night, in turns and on hillsides.
6. Make sure that SMV sign, warning lights and reflectors are clearly visible.
7. Never operate with tiller raised off ground to reduce possibility of injury from objects thrown under tiller structure.
8. Before dismounting, secure tiller in transport position or lower to ground, stop PTO, put tractor in park or set brake, stop engine and remove key. Never mount or dismount moving vehicle to prevent possible crushing injury or death.

<p>5. TRANSPORT SAFELY.</p> 	<p>6. USE SMV, LIGHTS & REFLECTORS.</p> 	<p>7. DO NOT OPERATE WITH TILLER RAISED.</p> 	<p>8. MOUNTING & DISMOUNTING VEHICLE.</p> 
---	---	--	---

RT1008

6



10

Decals

Item	Part #	Description	Qty.
1	RT1004E	Decal Warning "Serious Injury or Death"	1
2	D960	Decal Warning "Cancer & Reproductive Harm"	1
3	RT1005	Decal Warning "To Prevent Serious Injury"	1
4	RT1006	Decal Danger "Rotating Tines Hazard"	1
5	RT1007	Decal Danger "Rotating Driveline Hazard"	1
6	RT1008	Decal Danger "Failing to Follow Safety Messages"	1
7	D1015	Decal Logo "Tar River" Small	1
8	NA	Decal Model # "BXV-XXX"	1
9	NA	Decal Model # "CXT-XXX"	1
10	D1311	Decal "Gear Drive"	1

Warranty

LIMITED WARRANTY

Belco Resources Equipment warrants to the original purchaser of any new piece of machinery from Belco Resources Equipment, purchased from an authorized Belco Resources Equipment dealer, that the equipment be free from defects in material and workmanship for a period of one (1) year for non-commercial, state, and municipalities' use, ninety (90) days for commercial use from date of retail sale. Warranty for rental purposes is thirty (30) days. The obligation of Belco Resources Equipment to the purchaser under this warranty is limited to the repair or replacement of defective parts.

A four (4) extended Gearbox Limited Warranty is provided for TXG-YCT-RXT-CXT models at the end of the standard one (1) year warranty period. This warranty is not provided for commercial or rental uses. The extended warranty provides for the replacement of parts only. Not covered are oil seals or any damages to the gearbox due to lack of lubrications.

Replacement or repair parts installed in the equipment covered by this limited warranty are warranted for ninety (90) days from the date of purchase of such part or to the expiration of the applicable new equipment warranty period, whichever occurs later. Warranted parts shall be provided at no cost to the user at an authorized Belco Resources Equipment dealer during regular working hours. Belco Resources Equipment reserves the right to inspect any equipment or parts, which are claimed to have been defective in material or workmanship.

This limited warranty does not apply to and excludes wear items such as shear pins, tires, tubes knives, blades or other wear items. Oil or grease is not covered by this warranty.

All obligations of Belco Resources Equipment under this limited warranty shall be terminated if:

Proper service is not performed on the machine.

The machine is modified or altered in any way.

The machine is being used or has been used for purposes other than those for which the machine was intended.

DISCLAIMER OF IMPLIED WARRANTIES & CONSEQUENTIAL DAMAGES

Belco Resources Equipment obligation under this limited warranty, to the extent allowed by law, is in lieu of all warranties, implied or expressed, including implied warranties of merchantability and fitness for a particular purpose and any liability for incidental and consequential damages with respect to the sale or use of the items warranted. Such incidental and consequential damages shall include but not be limited to: transportation charges other than normal freight charges; cost of installation other than cost approved by Belco Resources Equipment; duty; taxes; charges for normal service or adjustment; loss of crops or any other loss of income; rental of substitute equipment, expenses due to loss, damage, detention or delay in the delivery.

REGISTRATION

The online Warranty Registration must be completed in order to qualify for coverage on this Limited Warranty. Visit br-equipment.com, click on "Warranty Registration" and completely fill out the form to register the new piece of equipment.

Page left blank intentionally

Page left blank intentionally

Page left blank intentionally



401 Jeffreys Road
Rocky Mount, NC 27804
www.tarrivermfg.com

Tel: 252-822-7140
Fax: 252-787-5855
Sales@tarrivermfg.com