

# BFT 135 -150

Sickle Bar Mower



TRANSLATION  
OF THE ORIGINAL  
INSTRUCTIONS

**USE and MAINTENANCE MANUAL**



issue 8 - 11/2018

# INDEX

	<u>Page</u>
• CE marking and serial plate	1
• Safety warning decals and specifications	2 - 3
• Decal and sign locations	4
• Main features	5
• Technical specifications	6
• Blade assembly instructions	7
• Attaching the sickle bar mower to tractor	8 - 9 - 10
• Tractor linkage of sickle bar mower with mechanical lift	11
• Tractor linkage of sickle bar mower with hydraulic lift	12
• Hydraulic cylinder flow valve adjustments	12
• Hydraulic kit assembly instructions	12
• Unhitching the sickle bar mower from tractor	13
• Cutting speed	14
• Safety release breakway latch	14
• Belt tension	14
• Blade replacement	15
• Manual raising and lowering of sickle bar mower blade	15
• Working position	15
• Greasing and maintenance instructions	16
• Cleaning of blade	16
• Storing the mower	16
• Breakdown drawings and Spare parts	17 - 22

### **CE Marking**

The herebelow CE Marking on the serial plate certifies that sickle bar mowers models BF 135T - 150T are in conformity with the safety requirements established by the european committee for standardization with amendent to Machine Directive EC/2006/42.

		ANNO	Kg		MADE IN ITALY
MODEL		SERIAL			

### **Serial Number**

Each unit is supplied with a serial plate placed on the front part of the internal protection guard specifying model and serial number.

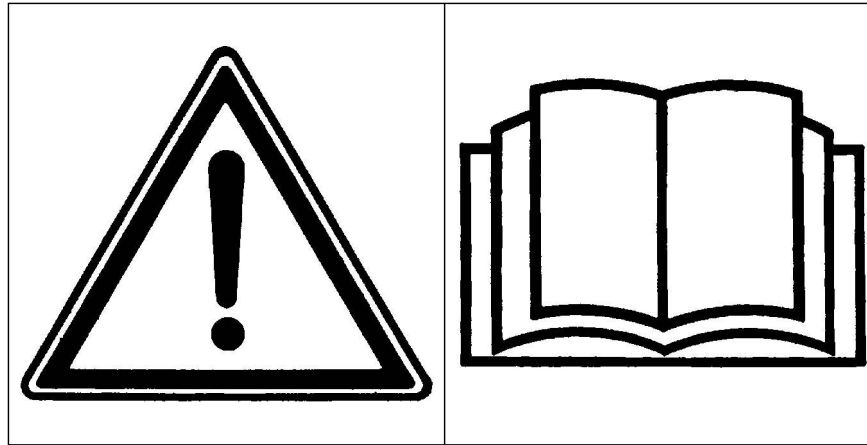

## SAFETY WARNING DECALS



**D A N G E R**

THE SYMBOL ABOVE CALLS YOUR ATTENTION TO INSTRUCTION CONCERNING YOUR PERSONAL SAFETY.

THE SAFETY AND INFORMATION DECALS ON THIS UNIT ARE INSTALLED TO ALERT OPERATORS TO DANGERS IN SPECIFIC MACHINE AREAS.

READ AND UNDERSTAND TO AVOID PERSONAL INJURY OR DEATH.



1. Read and understand the Operator's Manual.
2. Stop tractor engine and set parking brake before leaving operator's platform.
3. Keep riders off the machine.
4. Make certain everyone is clear of the machine before starting the tractor engine and operating.
5. Keep all shields in place.
6. Never lubricate, adjust, unclog, or service the machine with tractor engine running.
7. Wait for all movements to stop before servicing.
8. Keep hands, feet, and clothing away from moving parts.
9. Use flashing warning lights when operating on highways except when prohibited by law.
10. Maximum transport speed should not exceed 20 miles per hour.
11. Tractor must be equipped with Rollover Protective Structure (ROPS) and seatbelt.

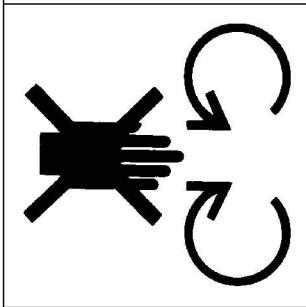

*Keep away from rotating driveline*

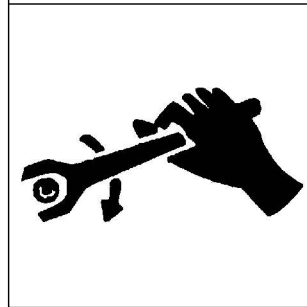

*Always check bolts are well tightened*

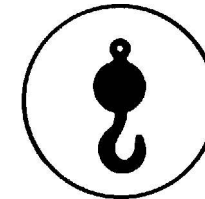

*Hook up points for lifting unit*

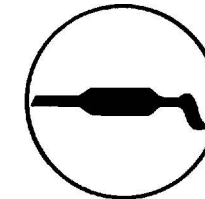

*Greasing points*

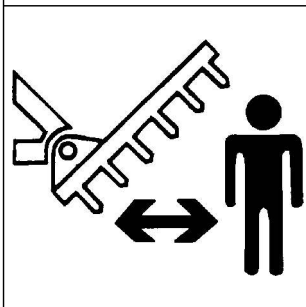

*Stay clear of folding blade when opening*



*Cutting of foot or leg blade movement*

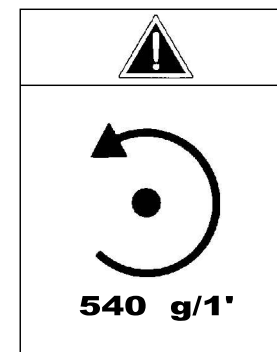

*Hook up points for lifting unit*

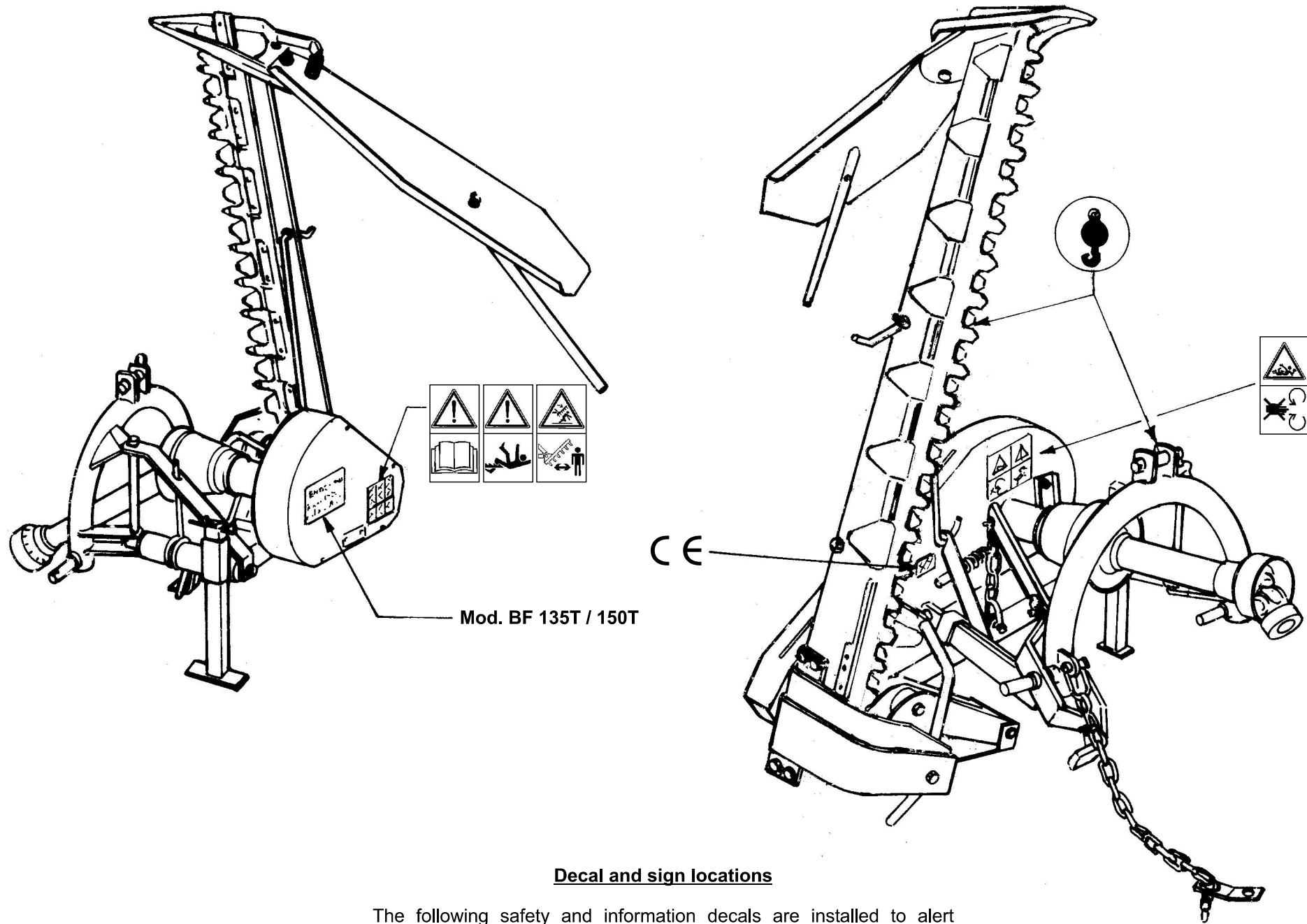

Mod. BF 135T / 150T

**Decal and sign locations**

The following safety and information decals are installed to alert operators to dangers in specific machine areas. The signs are for your personal safety.

**FIG. 1**

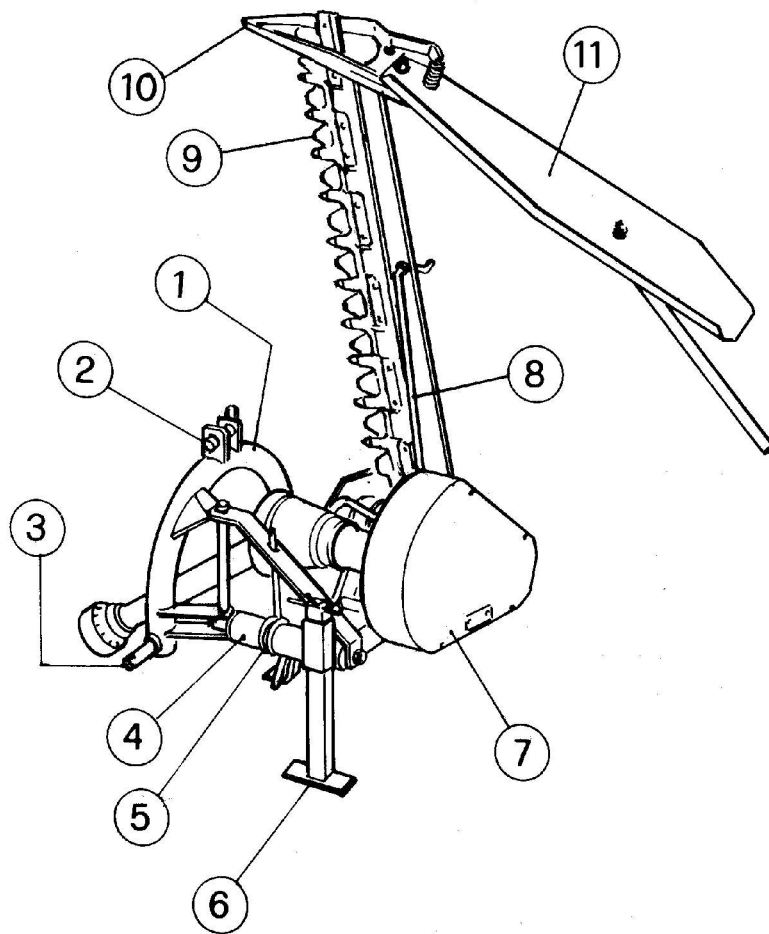

**Main features**

- 1) Frame
- 2) Upper 3° point hitch linkage
- 3) Lower 3° point hitch linkage
- 4) Frame articulation
- 5) Absorber spring
- 6) Foot support
- 7) Protection guard
- 8) Blade tierod

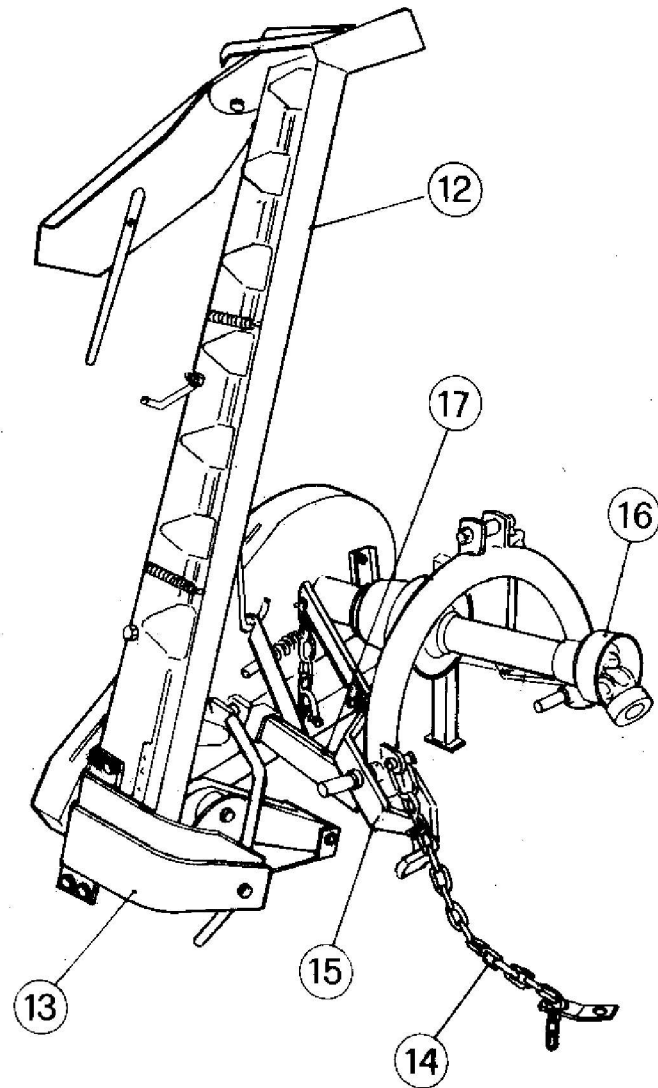

**FIG. 2**

- 9) Cutting blade
- 10) External shoe
- 11) Lateral deflector
- 12) Cutting blade protection
- 13) Skid
- 14) Height adjustment chain
- 15) Lifting bracket
- 16) P.T.O. shaft
- 17) Safety mechanism

### TECHNICAL SPECIFICATIONS

Double action sickle bar mower.

Safety release mechanism to protect unit from obstructions in field.

Blade inclination up to 75° downwards and 90° upwards (see drawing below).

Standard equipment includes: P.T.O. Shaft, transport blade protection and extra blade.

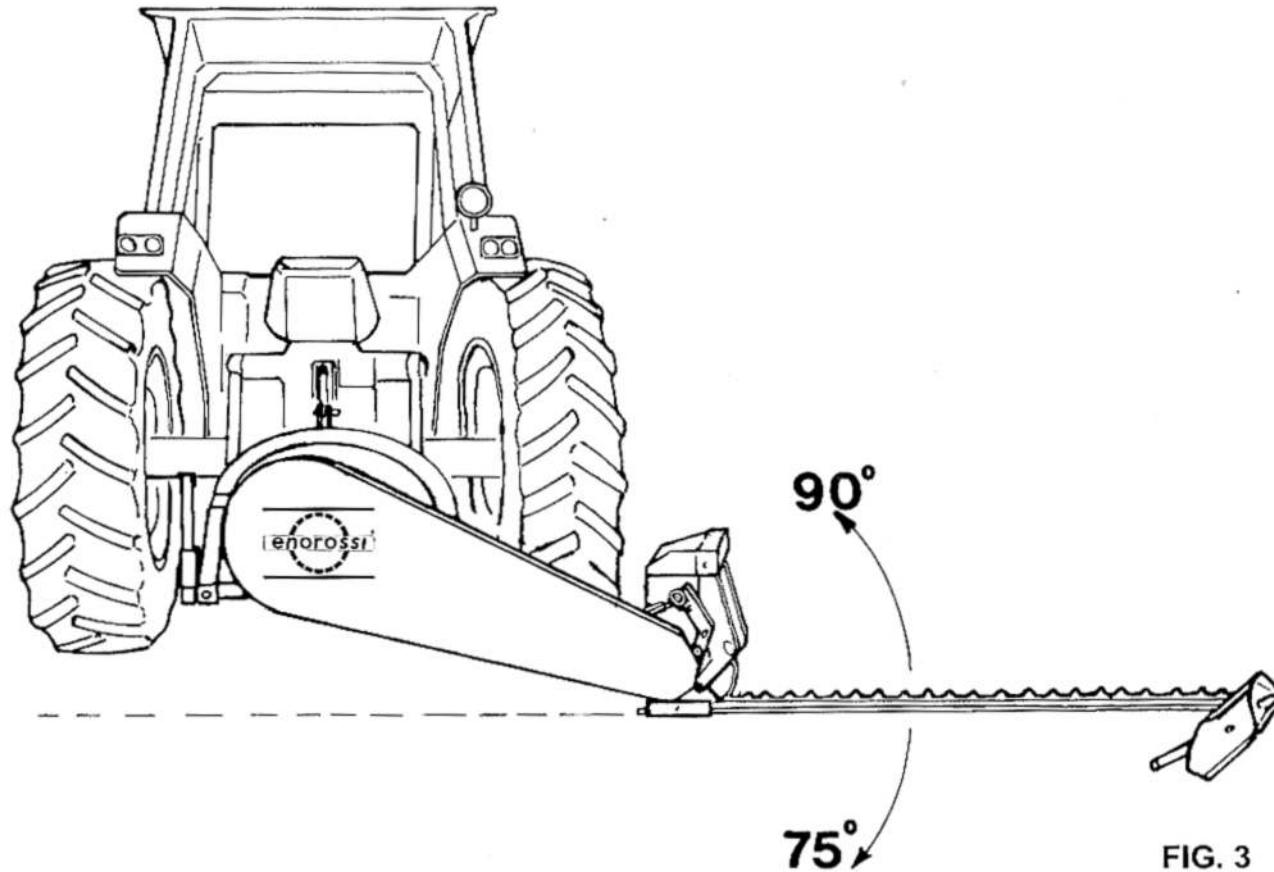

FIG. 3

MODEL	CUTTING WIDTH	WEIGHT LBS.	HP REQUIRED	P.T.O. rpm	WORKING SPEED
BF-135T	4" 5'	430	12	540	max 6 m.p.h.
BF-150T	5'	440	12	540	max 6 m.p.h.

N.B.: Weights include P.T.O. Cardan Shaft

## **BLADE ASSEMBLY INSTRUCTIONS**

Most sickle bar mowers are shipped disassembled and packed in crates therefore before proceeding to connect unit to tractor it is necessary to connect blade to three point hitch and main frame.

1) Blade assembly for sickle bar mowers with **MECHANICAL LIFT**:

Refer to figure 3.1 herebelow. Remove from support (1) pulley (3), snap ring E 80 and seeger ring  $\varnothing$  80. Insert support (1) into frame (2) and fasten with same snap ring and seeger ring. Screw on pulley (3) and connect chain (4) to link (5).

2) Blade assembly for sickle bar mowers with **HYDRAULIC LIFT**:

Refer to figure 3.2 herebelow. Remove from support (1) pulley (3), snap ring E 80 and seeger ring  $\varnothing$  80. Insert support (1) into frame (2) and fasten with same snap ring and seeger ring. Screw back on pulley (3).

Mount on upper pin of support (1) fork hinge (4), insert cylinder shaft (5) and fasten with screw TE 14x65 (6).

3) Mount the two belts and external protection guard.

4) Mount lateral deflector and fasten with screws TE 12x50 (12), washer  $\varnothing$  12 (13) and self-locking nut 12 MA (14). Insert screw TE 12x90 (7), washer  $\varnothing$  12 (8) and fasten with self-locking nut (11). Refer to Fig. 3.3.

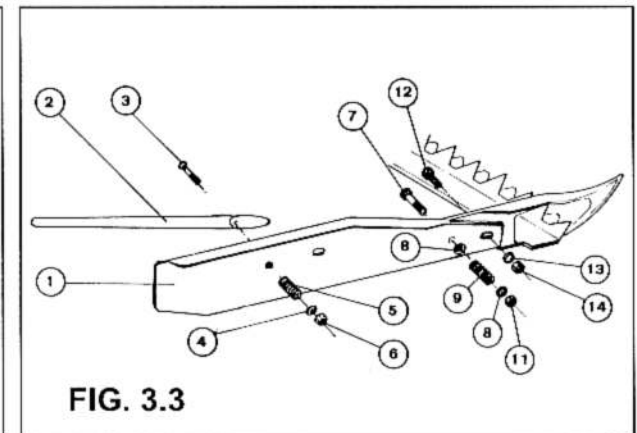
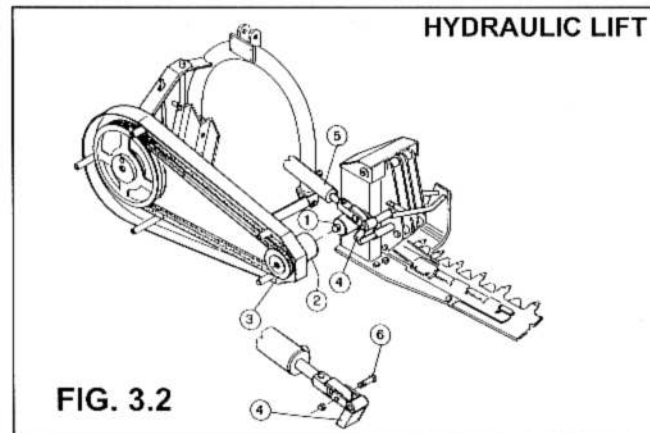
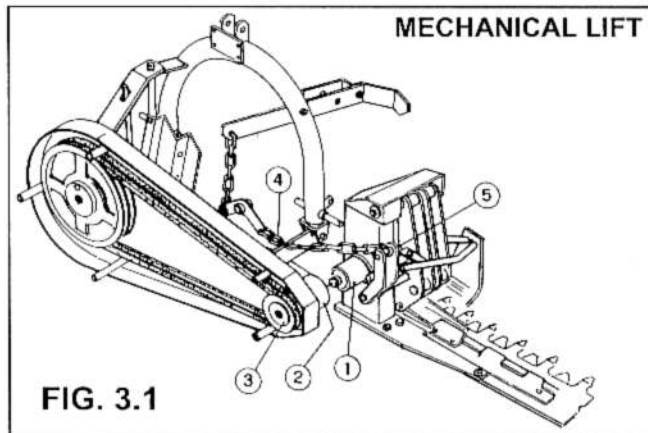

## ATTACHING SICKLE BAR MOWER TO TRACTOR

Before connecting unit to tractor make sure that all parts are properly in place and that all bolts and nuts are well tightened and all parts correctly lubricated.

- 1) Make sure that pins "A" (refer to Figure 4.1) of three point hitch are well cleaned and greased. Connect upper part of three point hitch linkage "G" to adjustment tierod "E". Connecting plate "F" must be placed on righthand side of adjustment tierod "E" and fastened with same pin. Connect tractor link arms "B". Lifting bracket "D", see Figure 4.2, must be positioned under arm "B" of tractor and blocked with pins "C" as in Figure 4.1.

**IMPORTANT:** According to the type of tractor you have use either internal or external pins "A" (see drawing below) so that internal skid of sickle bar mower "A" (see figure 4.3, page 9) remains behind tractor wheel.

- 2) Connect P.T.O. shaft "A", Figure 4.4 and make sure that it is well blocked to tractor P.T.O. Make sure that plastic protection guards rotate freely and connect P.T.O. shaft chain.

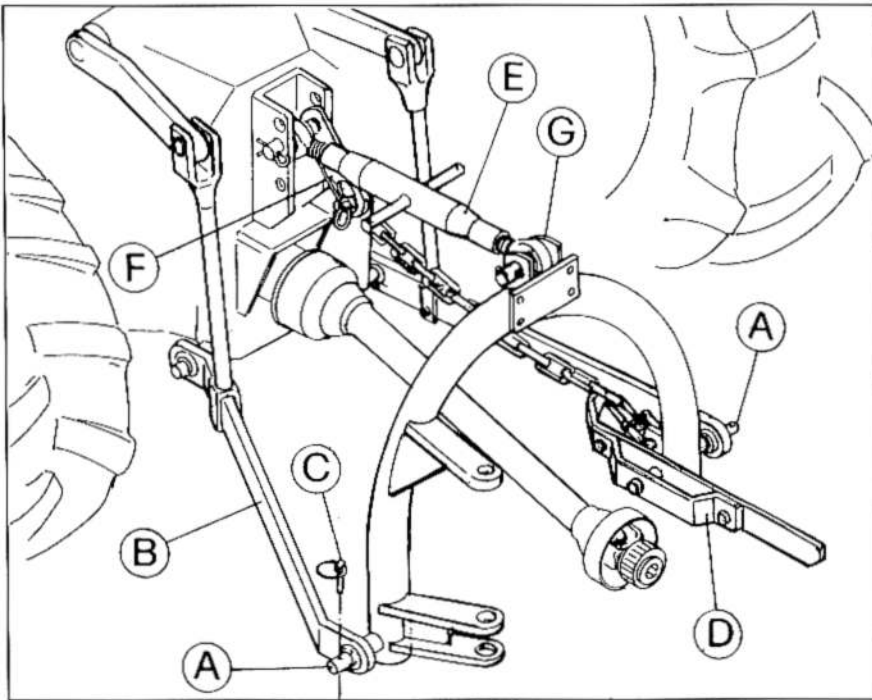

FIG. 4.1

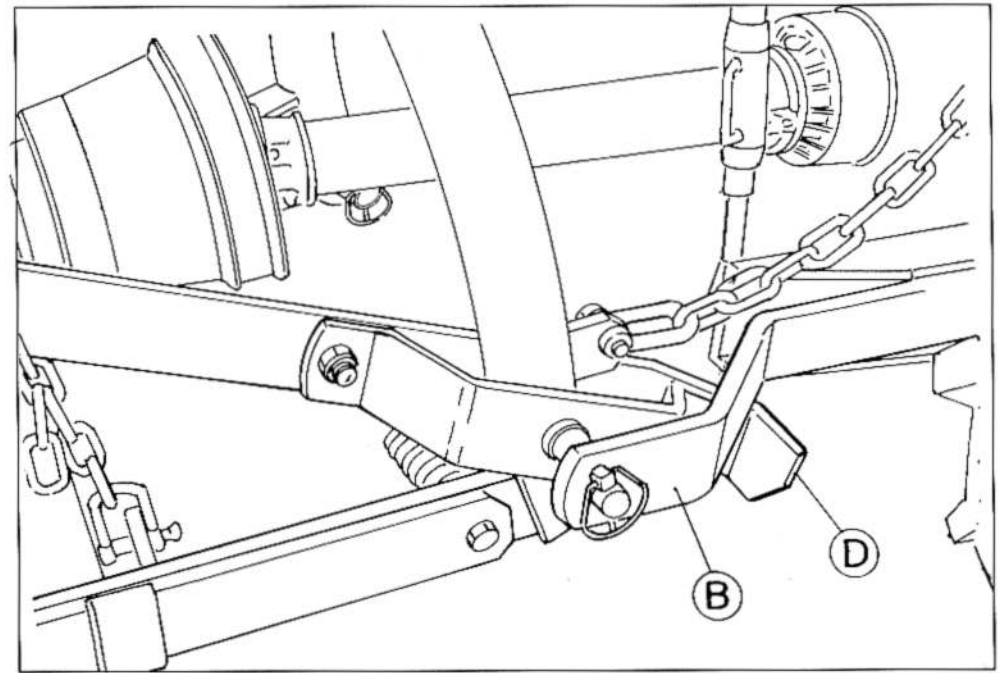

FIG. 4.2

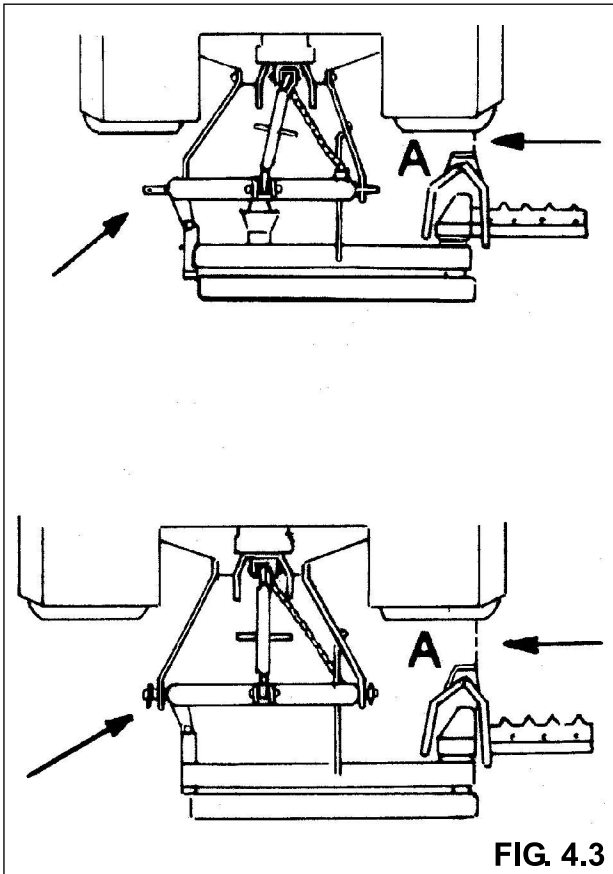

FIG. 4.3

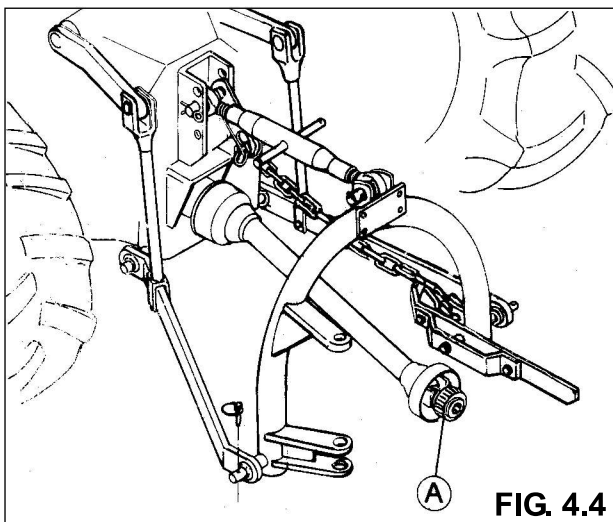
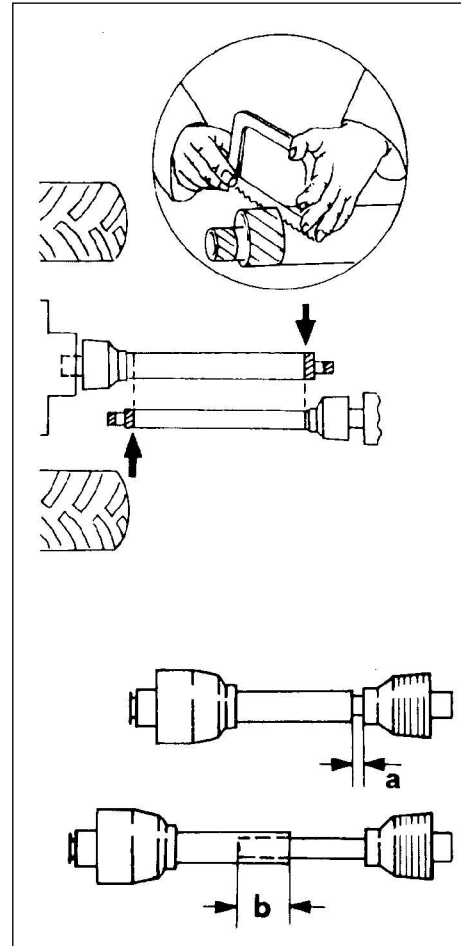

FIG. 4.4

## ATTACHING THE SICKLE BAR MOWER TO TRACTOR



### Adapting P.T.O. shaft

Sometimes it is necessary to shorten P.T.O. shafts according to type of tractor with which unit is used.

First check length before operating.

- Separate two shaft sections and fit same to P.T.O. shaft end of tractor and other to machine side. Slip clutch must be on machine side.

This operation must be carried out with unit hooked up to tractor.

- Overlap two shaft sections and make sure safety tolerances are respected both when three point hitch is lowered or lifted.

See above drawing.

Minimum tolerance must be 150 mm. (B) when P.T.O. shaft is open.

Minimum tolerance, when closed, should be 40 mm.

- If shortening is necessary cut off sliding and protection tubes uniformly.

- Trim tube ends, remove all swarfs and abundantly grease all sliding surfaces.

### ATTACHING SICKLE BAR MOWER TO TRACTOR

Insert chain "B" in Figure 4.5 into bracket "F" or use u-bolt (supplied by us) to connect chain to tractor. Make sure that chain is connected at approximately the same height of three point hitch and to a rigid location of tractor.

Using hydraulic lift raise sickle bar mower and adjust chain "B" so that P.T.O. shaft is in horizontal position during working operations. Clearance of lower part of sickle bar mower frame should be at 35 Cm. from ground as shown in Figure 4.6.

After adjustment is completed mark chain ring in order to have always the same cutting height. Raise foot support and place in working position, turning it upside down and fasten with split pin "A" as shown in figure 4.7.

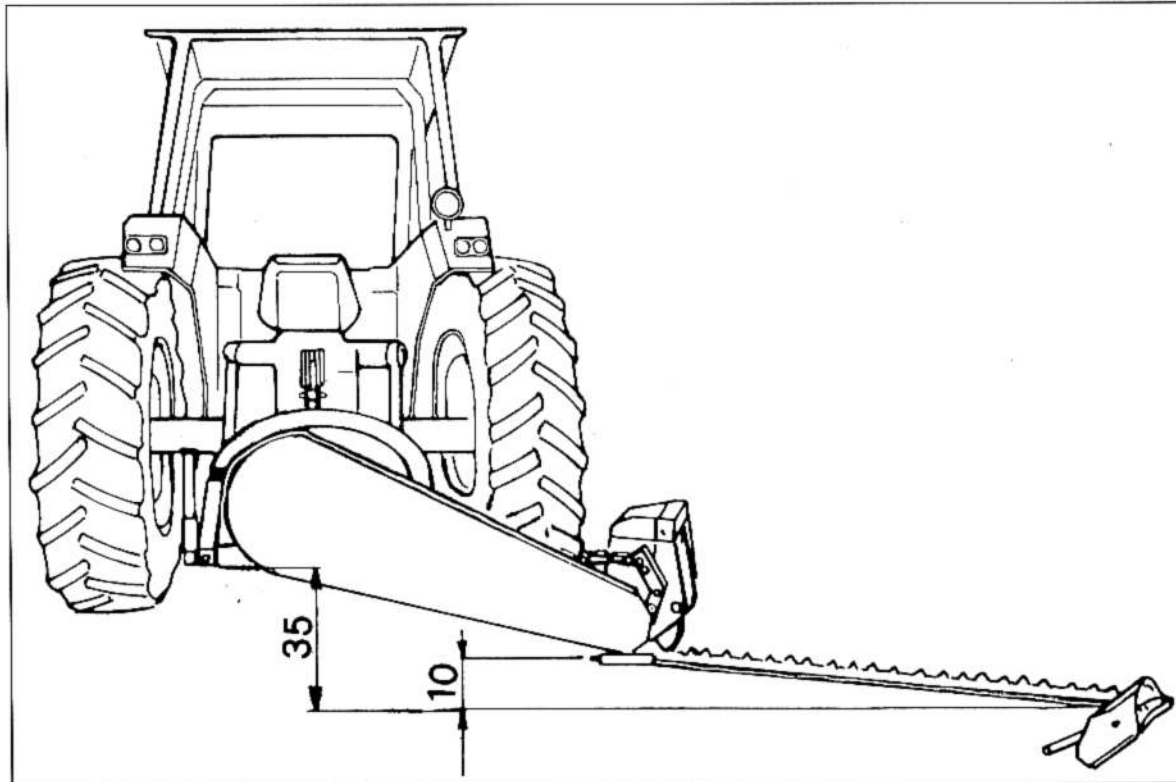

FIG. 4.6

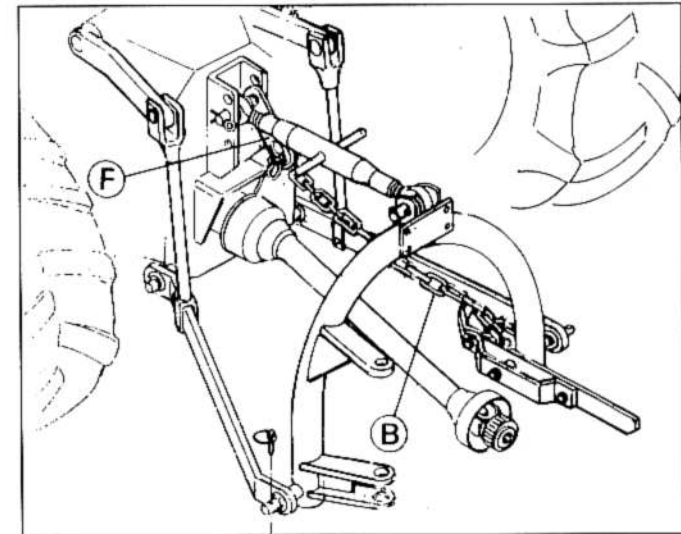

FIG. 4.5

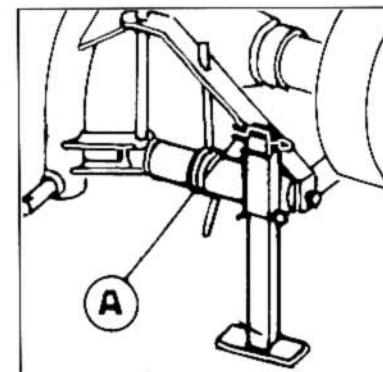

FIG. 4.7

### ATTACHING SICKLE BAR MOWER WITH MECHANICAL LIFT TO TRACTOR

Adjust chain "A", refer to Figure 5, in such a way that when sickle bar mower has been completely raised the safety release mechanism "D" leans lightly on frame on part marked "X" and with the inferior part of 3° hitch arch in Position "Y". If there is too much pressure this operation can be controlled by lengthening or shortening the chain using chain links. Lower machine in working operation and connect chain "C", Figure 5, to Position 12 / Table 3, allowing for a small margin of oscillation.

Adjust inclination of cutting knives according to ground conditions using tierod "D" as shown in Figure 5.1. In rough ground conditions or on-stony terrains we recommended to keep knives pointing upwards and to keep sickle bar mower adequately raised in order to avoid damage to knives and blade.

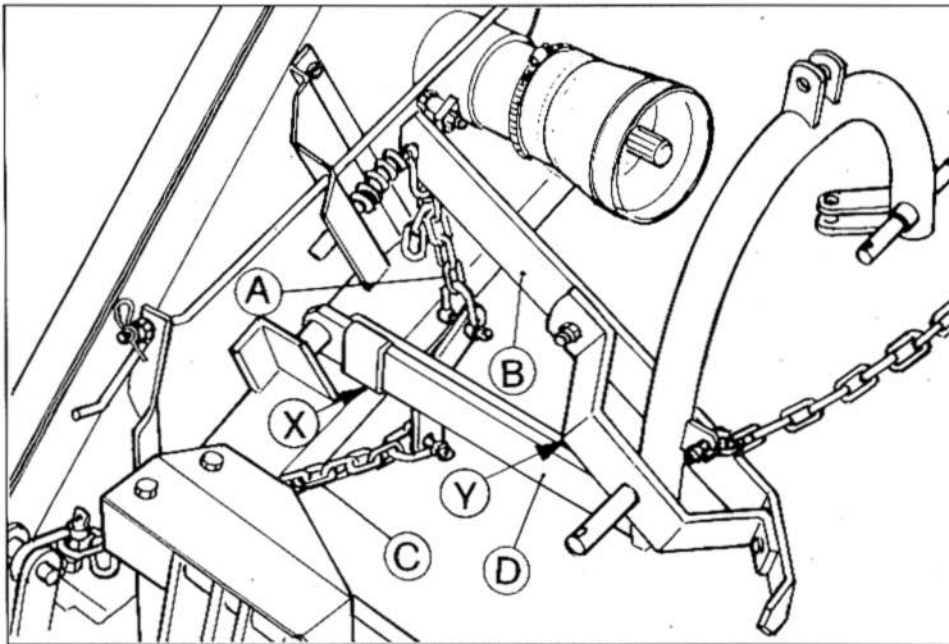

FIG. 5

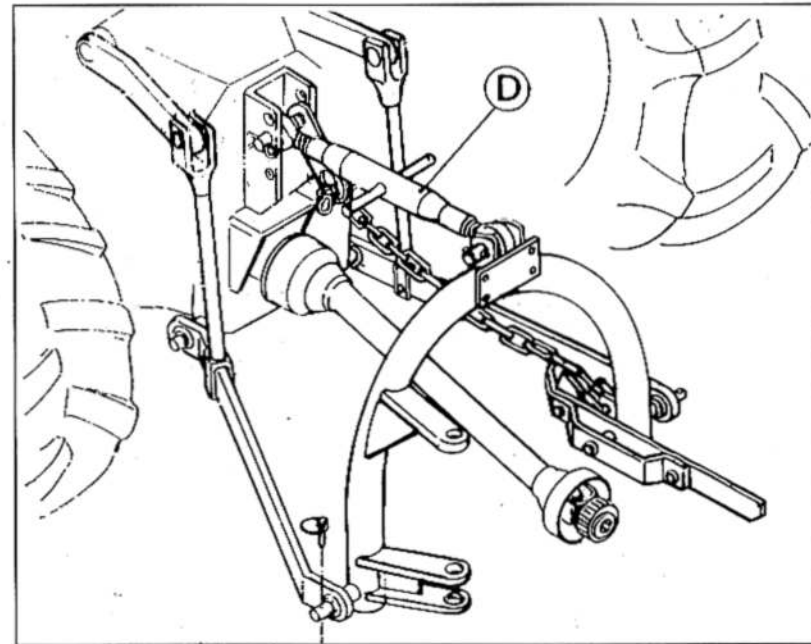

FIG. 5.1

## **TRACTOR LINKAGE OF SICKLE BAR MOWER WITH HYDRAULIC LIFT**

Connect hydraulic hose to tractor. Mount on tractor and close oleodynamic cylinder using distributor lever. This will raise unit completely. Control that raising and lowering operations of sickle bar mower are smooth. If adjustments are necessary read following instructions.

### **HYDRAULIC CYLINDER FLOW VALVE ADJUSTMENTS**

Refer to Figure 5.2.

If blade raises up too fast, from tractor seat turn valve "A" in clockwise direction. This will gradually reduce oil flow and consequently also reduce speed. Adjust until you obtain a slow raising movement.

If descend speed of mower is too fast, always from tractor seat, turn valve "B" in anti clockwise direction. This will gradually reduce oil flow and consequently reduce descending speed. Adjust till you obtain a slow movement.

If speed must be increased operate in opposite way.

### **HYDRAULIC KIT ASSEMBLY**

Refer to Figure 5.3 and mount hydraulic cylinder lift attachment "C" and fasten with screws T.E. 10x20. Connect cylinder "D" and fasten with pin "E" and roll pins 6x30.

Insert fork "F" and fasten cylinder shaft using screws and nuts 14x65 after having removed link Position 12, Table 3.

Connect hydraulic hose.

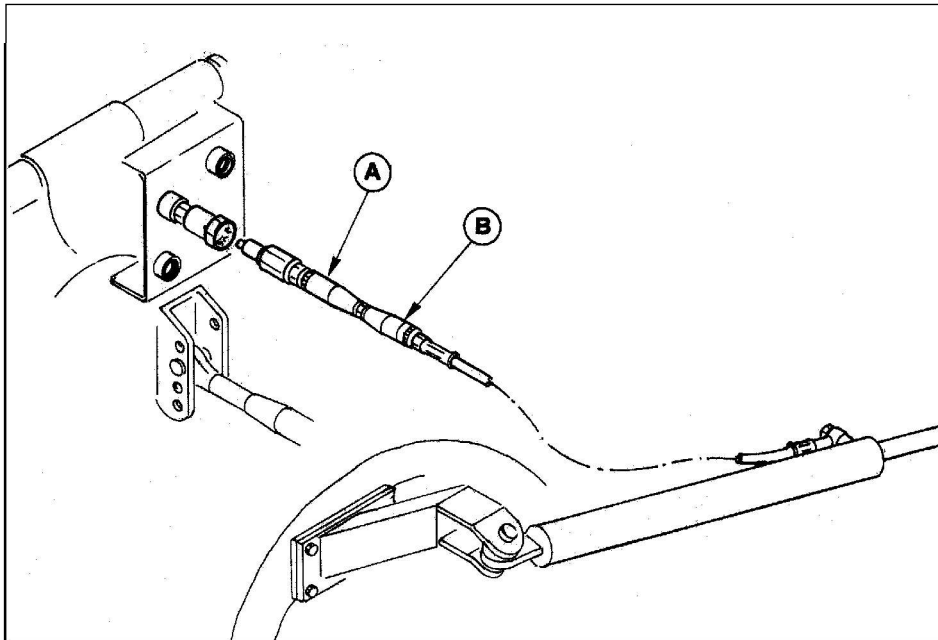

**FIG. 5.2**

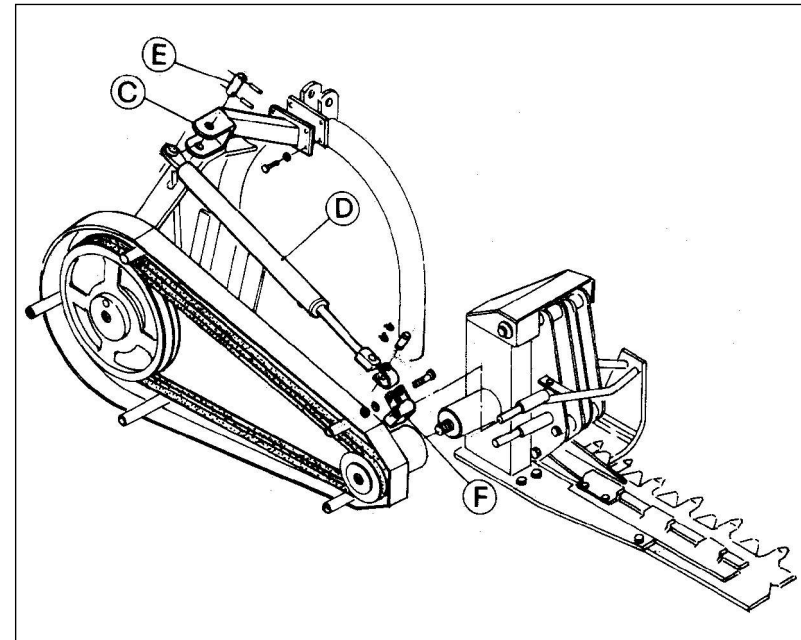

**FIG. 5.3**

### UNHITCHING SICKLE BAR MOWER FROM TRACTOR

- 1) Raise machine using hydraulic lift and disconnect chain "B" as shown in Figure 5.4.  
Turn around and lower foot support shown in Figure 5.5 and fasten with split pin "A".
- 2) Lower sickle bar mower, disconnect P.T.O. shaft, hydraulic lift arms and adjustment tierod.  
Unhitching operations should always be carried out on flat surfaces.
- 3) Disconnect hydraulic hose if you have a hydraulic model.

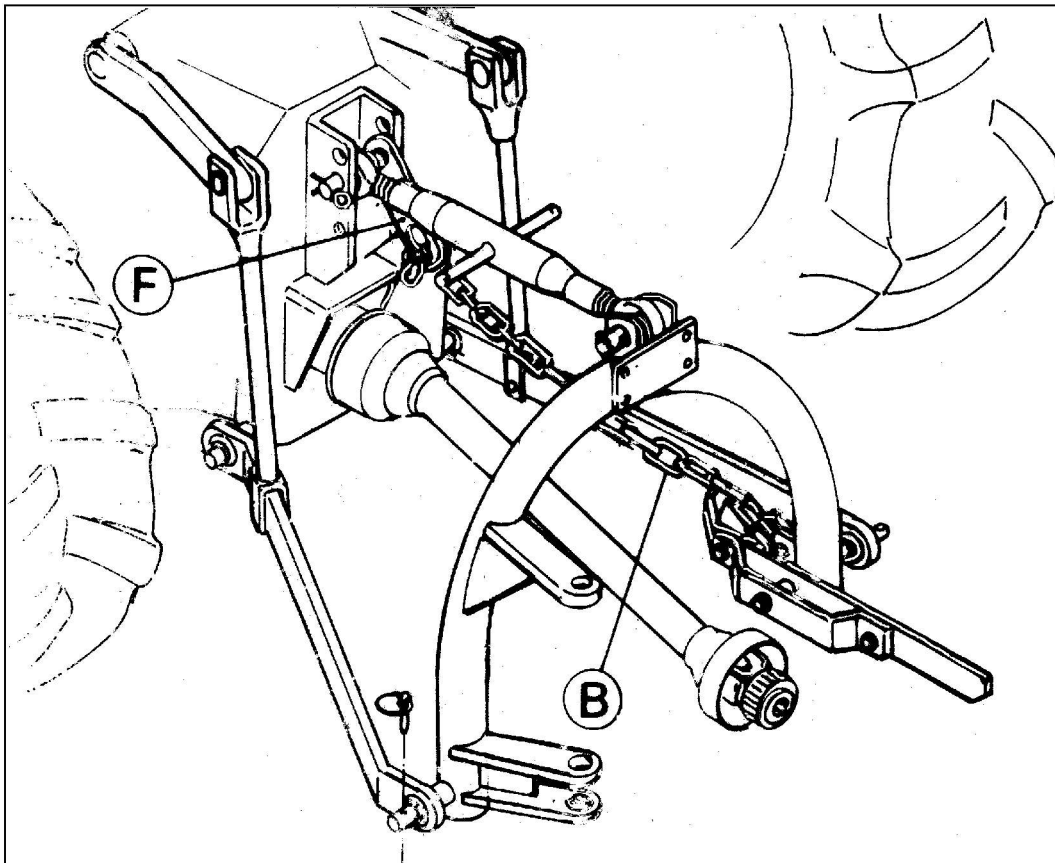

FIG. 5.4

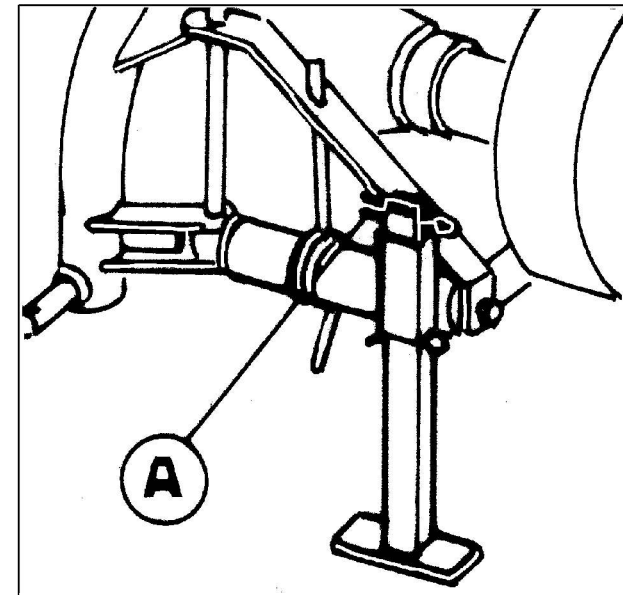

FIG. 5.5

### CUTTING SPEED

For a good quality cut we recommend that you engage P.T.O. speed between 400 to 450 Rpm. Do not operate over 540 Rpm and do not overspeed.

Keep tractor speed as high possible between 10 and 15 Km/h (6 to 10 Mph) to facilitate grass discharge.

In order to avoid clogging up of blade we recommend that sickle bar mower rests as close as possible to grass to be cut especially in the presence of flattened grass.

Be always aware of crop and field conditions. In rough field conditions speed should be reduced.

### SAFETY RELEASE BREAKAWAY LATCH

Sicke bar mower is protected with a safety release mechanism. If an obstruction is hit the cutter bar will swing back.

Stop tractor and do not raise sickle bar. Turn off tractor engine and make sure that P.T.O. shaft is not disengaged, if so, engage P.T.O. shaft in correct position. To reset safety release back up tractor until latch returns to its normal position.

If safety release latch breaks away too often adjust spring "B" using nut "A" (see Figure 5.6 herebelow) and tighten half turn at the time.

### BELT TENSION

Check periodically belt tension. Unscrew small window opening on protection guard (see Figure 5.7 herebelow). If necessary tighten belt using nut and counter nut "A" (Figure 5.8).

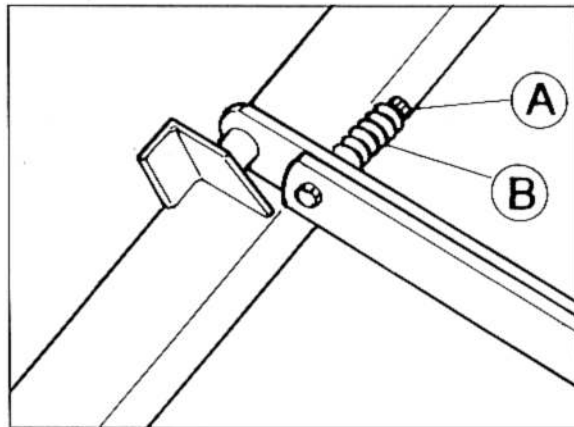

FIG. 5.6

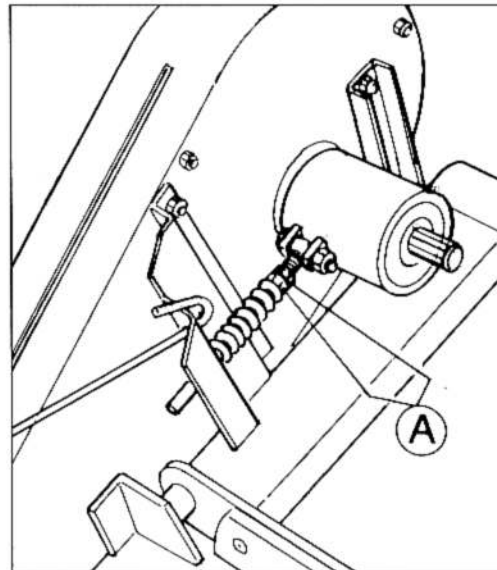

FIG. 5.7

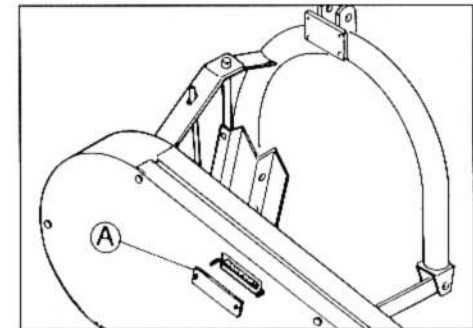

FIG. 5.8

### BLADE REPLACEMENT

Before replacing blade let sickle bar mower idle in order to eliminate any residues and facilitate extraction.

- 1) To replace blade loosen and remove nut "A" and bush "B" as shown in drawing below.
- 2) Use a cable to facilitate sliding out of blade as illustrated below.
- 3) When mounting new blade make sure to lubricate well all cutting knives with a good quality viscose oil.
- 4) Grease all parts indicated with grease zerk decals.

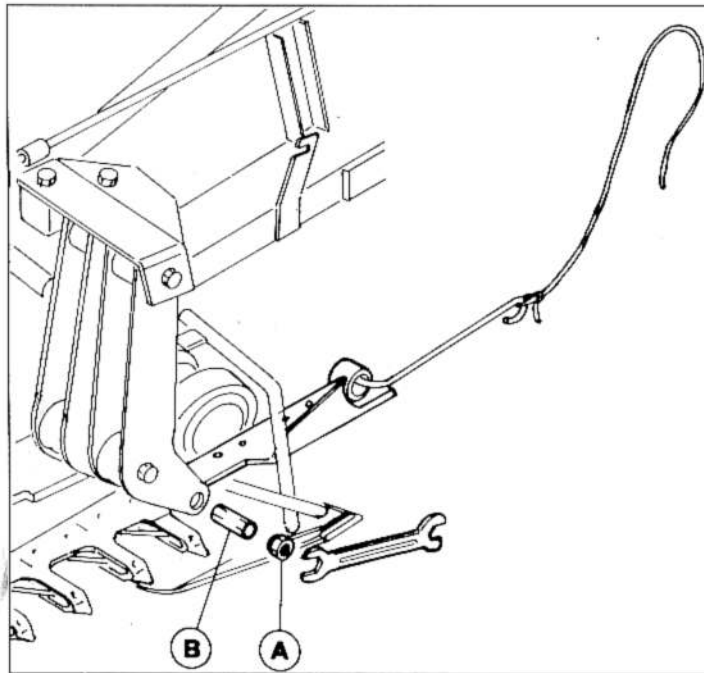

FIG. 5.9

### MANUAL RAISING AND LOWERING OF SICKLE BAR MOWER BLADE

Before carrying out any raising and lowering operations make sure to disconnect P.T.O. shaft from tractor make sure that all moving parts have come to a complete stop.

#### ROAD TRANSPORT

To transport the mower on a road or from a field to another raise mower to reduce overall length.

#### IMPORTANT

Lift sickle bar mower blade in vertical position block using tie rod hook "A" (Fig. 6.0) which was previously removed. Fasten tie rod hook "A" with handle "B" and insert split pin "C" and cover blade with protection guard cover. See Figure 6.1.

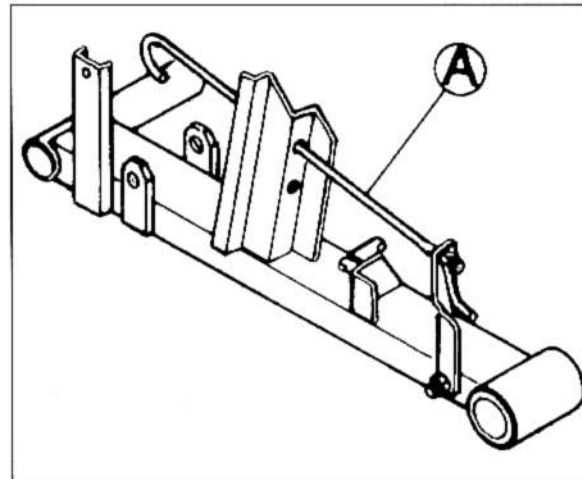

FIG. 6.0

### WORKING POSITION

Lower mower using hydraulic lift. Get off tractor and remove tie rod hook "A" (Fig. 6.1) and place in position on frame (Fig. 6.0). Lower sickle bar mower blade.

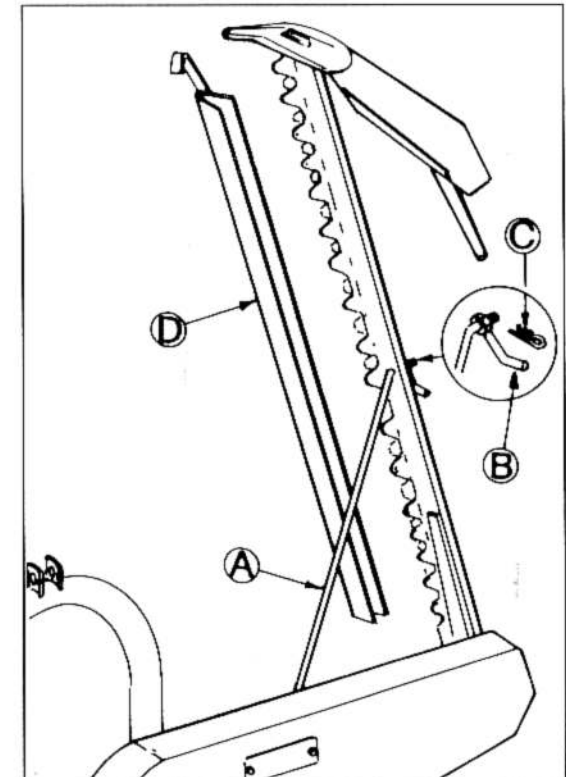

FIG. 6.1

### **GREASING AND MAINTENANCE INSTRUCTIONS**

- After every 2 working hours lubricate grease fittings as indicated by symbol in figures 6.2 and 6.3.
- After every 8 working hours:
  - Lubricate P.T.O. shaft cross journal
  - Check belt tension and if necessary tighten.
- After every 50 working hours check that all bolts are well tightened especially those located on blade movement, support, see Figure 6.2.

### **CLEANING OF BLADE**

Raise sickle bar mower using hydraulic lift. Make sure tractor is well parked and set brakes. Start sickle bar mower and wash with water using water hose and standing at a safe distance from unit. Make sure nobody goes near machine.

Turn off tractor engine and disconnect P.T.O. shaft. Check conditions of blade and of unit in general. When machine is dry lubricate knives and blade with a very viscose oil. Turn on tractor and start mower for a few seconds. Turn off tractor, disconnect P.T.O. shaft and install blade and external shoe protection.

### **STORING THE MOWER**

Clean mower, lubricate well knives and blade. Replace broken or worn out parts. Control and tighten all bolts and nuts. Lubricate also non-painted areas. Store in a dry place and out of reach of non-specialized personell.

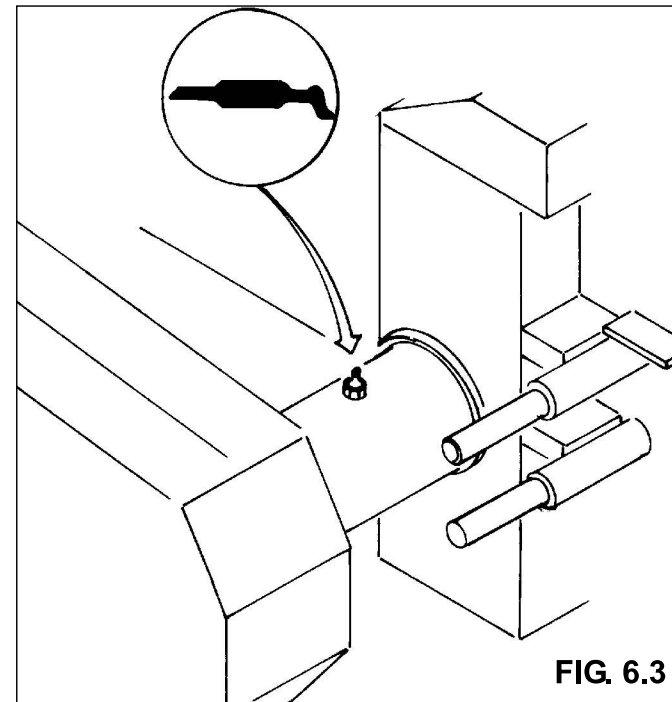
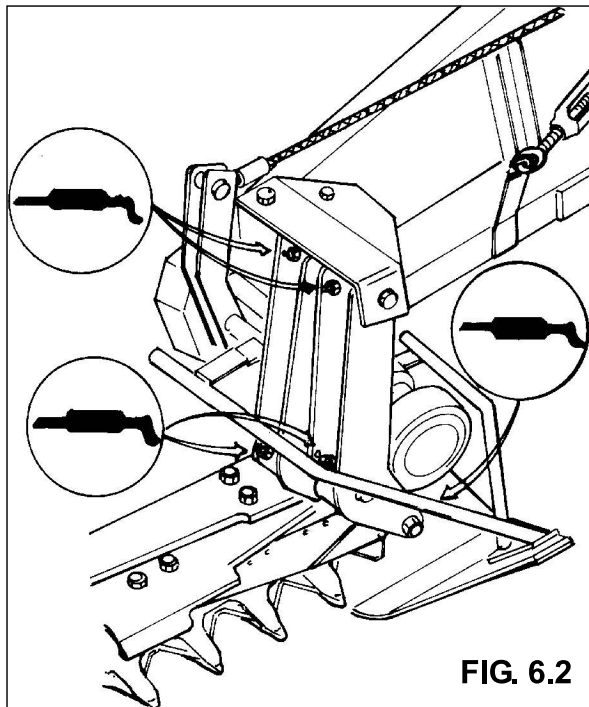

## WARRANTY POLICY

Our Company warrants its products to be free of defects in material and workmanship for a period of 1 year from the date of purchase under normal use and service providing the equipment is purchased for individual and not commercial use.

Our Company will replace any defective part but does not allow any labor cost. Defective parts will be sent prepaid. Retain defective parts in case they are needed for inspection by manufacturer. No warranty is made for items made by others since such items are warranted by respective manufacturers. No liability is assumed for expenses or damages resulting from the malfunction or interruption in operation of the equipment. This warranty does not apply to any equipment which has been damaged in any accident, or by fire, flood, act of God or has been subjected to abuse, misuse, negligence, alterations, and/or tampering.

Purchaser's exclusive remedy for breach of warranty, other defect, or conduct giving rise to liability shall be the repair or replacement of the product sold, and the manufacturer under no circumstances shall be liable for economic loss or incidental consequential damages. Effective upon the expiration of this limited warranty (one year from the date of purchase), the manufacturer disclaims all implied warranties, including the warranty of merchantability and fitness.

Our Company reserves the right to make improvements and changes in specifications without notice or obligation to modify previously sold units.

ENOAGRICOLA ROSSI s.r.l.  
06019 Calzolaro di Umbertide-Perugia-Italie  
Tél. (39) 075-930 22 22 - Fax (39) 075-930 23 28

e-mail: [enorossi@enorossi.it](mailto:enorossi@enorossi.it) – [info@enorossi.it](mailto:info@enorossi.it)  
web: <http://www.enorossi.it> - <http://www.enoagricolarossi.com>