

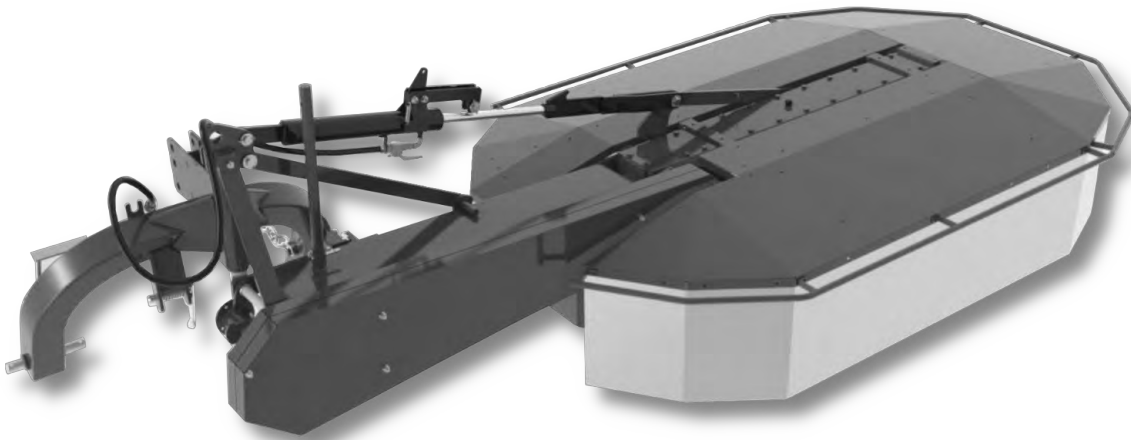

Drum Mower

BDR-210



Operator's Manual

Page left blank intentionally

TO THE DEALER:

Assembly and proper installation of this product is the responsibility of the Tar River dealer. Read manual instructions and safety rules. Make sure all items on the Dealer's Pre-Delivery and Delivery Check Lists in the Owner's/Operator's Manual are completed before releasing equipment to the owner.

TO THE OWNER:

Read this manual before operating your Tar River equipment. The information presented will prepare you to do a better and safer job. Keep this manual handy for ready reference. Require all operators to read this manual carefully and become acquainted with all the adjustment and operating procedures before attempting to operate. Replacement manuals can be obtained from your selling dealer. The equipment you have purchased has been carefully engineered and manufactured to provide dependable and satisfactory use. Like all mechanical products, it will require cleaning and upkeep. Lubricate the unit as specified. Observe all safety information in this manual and safety decals on the equipment. For service, your authorized Tar River dealer has trained mechanics, genuine Tar River service parts, and the necessary tools and equipment to handle all your needs. Use only genuine Tar River service parts. Substitute parts will void the warranty and may not meet standards required for safe and satisfactory operation.

Record your implement model and serial number in the space provide below. Your dealer will need this information to give you prompt, efficient service.

Model Number:

Serial Number:

Date Purchased:

TO THE DEALER: Part 1 of 2

Assembly and proper installation of this product is the responsibility of the Belco Resources Dealer. Read manual instructions and safety rules. Make sure all items on the Dealer's Pre-Delivery List and Owners Check List in the Owner's/Operator's Manual are completed before releasing equipment to the owner.



NOTE: The machine must be inspected thoroughly by the dealer prior to delivery of machine to owner. Place a check mark in the box beside each item checked. Contact Belco Resources Equipment of any damages, issues or shortages to the machine.

Pre-Delivery Checklist - Dealer

- Gearbox oil level
- Check all fluids, hydraulic, gear oil, etc.
- Grease fittings properly lubricated
- Guards, shields, attachments securely fastened
- All hardware tightened
- Condition and tension of V-belts (if applicable)
- Blades properly installed, blade hardware tightened to proper torque specifications
- PTO attached to the machine (if applicable)
- All decals are clean, legible and in proper location
- Operator's Manual on machine

Model #: _____ Serial #: _____

Inspected by (Initials): _____ Date: _____

TO THE DEALER: Part 2 of 2

Dealer is to review the following items to the owner. Place a check mark in the box beside each item reviewed.

Checklist - Owner

- Correct attachment of machine to tractor
- Safe operation of the machine
- Importance of regular lubrication, maintenance and inspection
- Troubleshooting
- Replacing broken or worn parts (importance of using only OEM parts)
- Servicing the machine
- Storage
- Warranty
- Encourage owner to read and understand the Operator's Manual before operating the machine
- Encourage owner to fill out the "Warranty Registration", online warranty@br-equipment.com

Purchase Date: _____ **Delivery Date:** _____

Model #: _____ **Serial #:** _____

Dealer Signature _____ **Date:** _____

Customer Signature _____ **Date:** _____

TO THE OWNER:

Read this manual before operating your Belco Resources equipment. The information presented will prepare you to do a better and safer job. Keep this manual handy for ready reference. Require all operators to read this manual carefully and become acquainted with all the adjustment and operating procedures before attempting to operate. Replacement manuals can be obtained from your selling dealer. The equipment you have purchased has been carefully engineered and manufactured to provide dependable and satisfactory use. Like all mechanical products, it will require cleaning and upkeep. Lubricate the machine as specified. Observe all safety information in this manual and safety decals on the equipment. For service, your authorized Belco Resources dealer has trained mechanics, genuine Belco Resources service parts, and the necessary tools and equipment to handle all your needs. Use only genuine Belco Resources service parts. Substitute parts will void the warranty and may not meet standards required for safe and satisfactory operation.



ATTENTION!

Before using the machine, please thoroughly read this User Manual and observe the safety instructions contained herein.

The User Manual constitutes an inherent part of the machine!

Keep the User Manual in a safe place, where it should be accessible to the machine operator during an entire lifespan of the machine.

In the event of its loss or damage, you must acquire a new copy from the machine dealer or distributor.

If you sell or hand over the machine to another user, please attach the User Manual together with the machine's operating instructions and its Declaration of Conformity.

The distributor reserves the copyrights to this User Manual.

Copying, processing of the User Manual and its parts without the distributor's permission is strictly prohibited.

Manufacturer guarantees the efficient operation of the machine, providing it is being used in accordance with the technical and operating conditions specified in this USER MANUAL.

Any faults revealed during the warranty period will be repaired by the Warranty Service.

Expiration date of the warranty period is specified in the WARRANTY CARD.

Machine parts and components, which are subject to wear in normal operating conditions, are not covered by the warranty, regardless of the warranty period.

Warranty Service covers only instances such as: mechanical damages not caused by a fault of the user, production defects, etc.

The group of elements includes, among others, the following parts/components:

- cutting blades,
- protective aprons,
- bearings.

In the event of damages resulting from:

- mechanical destruction caused by a fault of the user or a traffic accident,
- improper use, adjustment, and maintenance, use of the machine for a purpose other than intended,
- use of a damaged machine
- repairs conducted by unauthorized persons, improper repairs,
- arbitrary changes and modifications of the machine structure,

the user's rights to Warranty Service may become invalid.

The user is obliged to immediately report any noticed damages of paint coat or spots of corrosion, and order repairs regardless whether or not the damages are covered by the Warranty. Warranty conditions are specified in detail in the WARRANTY CARD attached to the purchased machine.



ATTENTION!

You must demand from the dealer to properly fill out the Warranty Card. For example, if the date of sale or the stamp of a dealer are missing, you risk that your complaints will not be considered valid



ATTENTION!

After a few hours of the machine operation, check the tension of all V-belts. If their play is too large, tighten them.

Table of Contents

1. Introduction	5
2. Machine identification	6
3. Rules of safe operation	7
3.1. User safety	7
3.2. Residual risk assessment.....	9
3.3. Safety signs on the machine and their meaning.....	11
4. Intended use of the machine	13
5. Equipment and accessories.....	14
5.1. Basic equipment.....	14
5.2. Technical characteristics	14
6. Machine usage	16
6.1. Mower assembly.....	17
6.2. Connecting the mower to a tractor	17
6.3. Transport position.....	18
6.4. Working position.....	21
6.5. Adjusting the mower.....	21
6.6. Operation of the mower	22
7. Operation and maintenance	23
7.1. Adjustment of the V-belts tension	24
7.2. Replacing the blades:	25
7.3. Maintenance after work	26
7.4. Lubrication	27
7.5. End of season servicing.....	27
7.6. Possible problems and solutions.....	28
8. Disassembly, disposal, and environment protection.....	29
9. Spare Parts Manual.....	30
9.1. How to order spare parts.....	30
9.2. General construction – BDR 210 mower.....	31
9.2.1. Suspension system	32
9.2.1. Middle frame.....	33
9.2.2. Hydraulic system.....	36
9.2.1. Metal cover	38
9.2.2. Main frame.....	39
9.2.1. Cutting unit – working part	41
11. Records of warranty repairs.....	55
12. Warranty form	56
13. Assembly Instructions.....	57-71

1. Introduction

Before the first use of the mower, you must thoroughly read and understand this User Manual, and follow all the instructions contained herein.



ATTENTION!
Before first use, read the User Manual

This User Manual describes hazards, which may occur when you do not follow the safety precautions when operating and maintaining the mower. The User Manual lists the safety precautions which must be observed in order to minimize and to avoid the hazards.

The User Manual also contains the rules for proper use of the mower and explains the required maintenance procedures.

If you do not understand any information contained herein, please contact the distributor.



ATTENTION!

This warning symbol alerts about a hazard.

The warning symbol indicates an important hazard information provided in the User Manual. Please read the information carefully, follow the instructions and be exceptionally careful.

2. Machine identification

Each mower has its rating plate, containing the most important identification data. The rating plate is located on the machine in a place, where it is easy to find and read.



Fig. 1 Rating plate

The rating plate includes:

- full name of distributor
- mower serial number
- mower model

3. Rules of safe operation

3.1. User safety

The rotary mower can only be used by adults, who have learned its operation and read this User Manual and are properly qualified. Mowers should be handled with all safety precautions, and in particular:

- In addition to the guidelines outlined in this User Manual, also observe the general principles of occupational health and safety!
- Observe the warning symbols displayed on the machine.
- It is strictly forbidden, that the machine shall be operated by anyone under the influence of alcohol or other intoxicants.
- Never allow the vehicle servicing the mower to be driven by a person other than the mower operator, and under no circumstances allow any other persons to be on the vehicle, or on the machine, during its operation.
- The mower may be operated by a person with the proper authorization to drive the vehicle to which it is attached, in accordance with the distributor's instructions.
- The operating position of the operator, while working with the mower, is the cabin of the vehicle to which the machine is attached.
- Please note, that there are many elements of the mower that may cause an injury (sharp edges, protruding parts, etc.). Use extra caution when moving around the critical elements and obligatorily use the personal protective equipment, such as:
 - protective clothing,
 - protective gloves,
 - protective footwear
- It is forbidden to carry persons or objects on the machine.
- It is forbidden, that the machine should be operated by persons, who are not familiarized with the User Manual.
- The mower operator should be provided with the first aid kit, also containing instructions for its use.
- When driving a vehicle with the attached, but not working mower, ensure the safe transportation height of ~ 0,4m.
- Before driving, the mower must be set to the transportation position, and raised with the rear three-point hitch. When parking, the machine should be lowered.
- Take special care when driving on public roads and comply with the applicable road traffic regulations.
- When driving on public roads, it is essential to use the electric outline lighting of the vehicle, check its efficiency and visibility, and keep it clean. The user is obliged to ensure the visibility of a machine during its transportation: use the reflective markings and warning signs - may be included as an option. The transportation speed should be adjusted to the condition of a road surface, it should not, however, exceed 15 km/h.
- Do not leave the vehicle with the mower on a hillside or on another sloping surface, without securing the vehicle from rolling down. The mower should be lowered to the ground. Truck wedges should be placed under the vehicle tires.

- The mower must be adjusted to working height, during its attachment to the vehicle. During the mower operation certain adjustment is possible, it should be done from the inside of vehicle cabin, and operator should never leave the cabin.
- Any preparations, fitting, dismantling or adjustment can be performed only after the drive has been switched off, the engine stopped, the vehicle immobilized and when all the moving parts of the machine have stopped.
- After first hour of operation, check the status of all separable connections, including bolts.
- The mower should be kept on a flat, level, paved surface, out of the reach of strangers and animals. For stabilizing the mower use the support foot.
- During the fitting and dismantling of mower you should be careful, paying particular attention to the structural elements used for fixing the mower to a vehicle.
- Before using the mower, you must check the condition of mower and of the vehicle it is attached to. The vehicle and mower unit should be in good mechanical condition. Immediately replace parts which are worn out or damaged.
- The mower must be equipped with all the safety guards (provided by the manufacturer), preventing access to any moving parts. The guards must be complete and fully operational.
- Work with the mower without the guards and mudguard is not allowed. Work with the damaged guards or raised mudguard is forbidden.
- It is also forbidden to lift the mower, while the drives are working, and the reels are rotating.
- It is not allowed to control the lever of hydraulic lift from outside of the tractor.
- Before beginning to work with the mower, you should familiarize yourself with the way it operates, occupational safety rules and recommendations for maintenance and adjustment procedures, by reading this User Manual.
- Weight of the mower suspended on a vehicle can affect the vehicle's maneuverability. Under these circumstances you must exercise extreme caution.
- The User Manual should be kept on the machine. When letting the machine to other user, you must ensure that it is in good mechanical condition, and that the User Manual is also handed over.
- It is prohibited to attach any additional means of transportation to the mower.
- During commissioning, check the machine functions and make the initial adjustments, without a load.
- Assembly protection of the three-point hitch of the mower with pins, should be made only using the typical secure cotter pins. Using any other break-back devices is prohibited.
- Due to the natural wear, you must control the condition and completeness of the machine cutting tools, following the instructions laid out in Chapter 7. Operation and maintenance
- On receipt of the mower after its transportation, you must make sure that the machine has not been damaged and check its mechanical condition.
- It is forbidden to stand under the raised mower, as it may result in being crushed by the machine.
- When adjusting, do not place your fingers and limbs between the structural elements of the machine.
- It is forbidden to leave a tractor's cabin when the machine is running, and before all the rotating parts have stopped
- Operator of the vehicle working with a mower, must ensure that no person is approaching the machine during its operation, and **the distance of not less than 50m from the working mower is always maintained.**
- Before switching on a mower's drive, lower the cutting unit to its working position.

- Mowing may be started only after PTO reaches the nominal speed of 540 rpm. It is forbidden to overload the PTO shaft of the mower and engage the clutch suddenly.
- When turning, reversing, or maneuvering with the machine, you must ensure that your visibility is adequate, or get assistance from a properly trained person.
- **It is prohibited to perform mowing while reversing the vehicle.** When reversing, lift up the machine.
- When connecting the hydraulic lines, make sure that the hydraulic system is not pressurized.
- It is forbidden to stand between the vehicle and the mower, while the vehicle's engine is running.
- Working on slopes exceeding 10% is not allowed.
- Pay special attention when working on slopes.
- When driving on curves and turning, switch off the PTO drive.
- It is forbidden to operate the machine in close proximity of public squares (parks, schools, etc.) or on stony grounds, to avoid the danger coming from the thrown-out stones and other objects.
- Do not allow the PTO working speed to exceed 540 rpm, while driving speed must be adjusted to the type of work being done.
- Working with damaged or incomplete articulated telescopic shaft is forbidden. And it is strongly forbidden to work without covers on moving parts.
- The telescopic shaft has marks indicating which end must be connected to the tractor before work please make sure that the direction of rotation of the shaft is correct.
- Never leave a vehicle with the engine running. Before leaving the driver's seat (the cabin), lower the machine to the ground, turn off the engine of the vehicle, remove the ignition key, and apply the handbrake.
- Make sure that during work, fitting, dismantling or adjustment of the machine, no parts of your work clothing are unbuttoned or hanging loose. You should keep elements of your clothing away from any machine parts that are likely to catch them.
- It is advisable to clean and wash the mower in a washing stand equipped with a sewage treatment feature or a settling tank, to neutralize the waste water.
- The machine should be kept and stored in places protected from unauthorized access of persons and animals, thus eliminating the risk of accidental injuries, on a flat, hardened surface, under a protective canopy.
- In the event of failure, immediately switch off the drive transferring power from the vehicle to the mower.
- When working with the mower, use hearing protection headphones to minimize the exposure to noise. In addition, it is recommended to close the doors and windows of the vehicle's cabin.



Failure to observe the above guidelines may present danger for the operator and other persons, as well as damage the mower. The user is responsible for any damages caused by the non-compliance to the above principles.

3.2. Residual risk assessment



Manufacturer has made every effort to ensure that the design of the mower, and its intended use, do not pose any risk to persons or the environment.

Due to the nature of work being done by the mower and, for example, the inability to completely cover the machine's cutting unit, certain risk factors may occur.

<i>No.</i>	<i>Hazard</i>	<i>Hazard source (cause)</i>	<i>Hazard protection measures</i>
1	Drive system overload (physical weight)	Work in a standing, forced-bent position, walking, moving items	Reading and understanding the User Manual, workplace training including lifting standards for the manual transportation labor, proper techniques for lifting and carrying weights, use of another person's assistance, moving equipment such as jacks, winches
2	Fall on the same level (tripping, slipping, etc.)	Uneven terrain, messy environment - objects lying around and, cables lying on roads, and also slippery surfaces	Suitable footwear, level ground, paying attention, maintaining order, familiarization with the User Manual
3	Hitting stationary, protruding parts of the machine	The machine and its surroundings	Proper positioning of a machine, safe space to move around, proper organization of work, paying attention, familiarization with the User Manual
4	Being hit by moving objects	Mowed plants, accidentally removed soil, stones	Paying attention, establishing a danger zone, prohibiting any traffic near the working machine, banning persons from standing within the 50m range from the working machine, using personal protective equipment - protective helmet, glasses, familiarization with the User Manual
5	Sharp, dangerous edges	Protruding structural elements of the machine, use of manual tools	Personal protective measures – protective gloves, buttoned up work clothes, paying special attention
6	Belt transmission systems	Fast moving transmission pulleys and belts, rotating articulated telescopic shaft, no covers on the movable parts	Eliminate moving around, approaching, and adjusting the machine, while running, paying special attention, familiarization with the User Manual
7	Weight of the suspended standing machine	Improper mounting, aggregating, wrong setting of the machine, improper operation, leaving the suspended machine on a tractor	Paying special attention, use of personal protective equipment - safety footwear, protective gloves, secure setting of the machine, help of another person, use of lifting jacks, davits, familiarization with the User Manual
8	Microclimate - changing weather conditions	Work performed in different weather conditions	Suitable working clothes, beverages, creams with sunscreen, proper rest, familiarization with the User Manual

9	Noise	Too high rotational speed of the machine, damaged, loose, vibrating parts	Work only with the machine in good mechanical condition, regular inspections, proper rotational speed, familiarization with the User Manual
---	-------	---	---

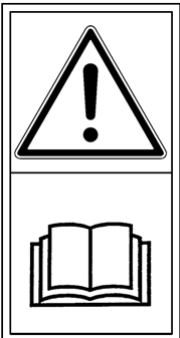
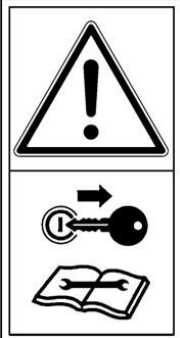
3.3. Safety signs on the machine and their meaning

	 <p data-bbox="572 2002 943 2060">1.1 - Switch off the engine and remove the ignition key before</p>	 <p data-bbox="995 2002 1366 2060">1.2 - Keep a safe distance from the machine. Do not allow</p>
---	---	---

<p>1.0 - Prior to using the machine, read the User Manual</p>	<p>beginning any servicing or maintenance procedures</p>	<p>unauthorized persons within the range of 50 m from the machine</p>
<div data-bbox="215 257 391 609" data-label="Image"> </div> <p>1.3 – Do not attempt to perform any repairs while working</p>	<div data-bbox="667 212 849 555" data-label="Image"> </div> <p>1.4 - Do not ride on platforms and ladders</p>	<div data-bbox="1088 212 1270 555" data-label="Image"> </div> <p>1.5 - Do not stand near the lifting jack connectors, when controlling the jack</p>
<div data-bbox="225 714 411 1070" data-label="Image"> </div> <p>1.6 - Do not open or remove safety guards, when the engine is running</p>	<div data-bbox="662 714 855 1077" data-label="Image"> </div> <p>1.7 - Keep a safe distance from power lines</p>	<div data-bbox="1082 714 1270 1070" data-label="Image"> </div> <p>1.8 - Avoid impact of liquids flowing under pressure. Read the User Manual and learn about the operation procedures</p>
<div data-bbox="204 1245 379 1594" data-label="Image"> </div> <p>1.9 – Caution, loose rotation tools</p>	<div data-bbox="651 1229 823 1579" data-label="Image"> </div> <p>2.0 - Caution, cutting blades. Do not approach a working mower</p>	<div data-bbox="1082 1223 1251 1559" data-label="Image"> </div> <p>2.1 Caution, V-belts. Keep away</p>
	<div data-bbox="541 1738 679 1877" data-label="Image"> </div> <p>2.3 - Use protection suit</p>	<div data-bbox="995 1715 1150 1865" data-label="Image"> </div> <p>2.4 – Use protective gloves</p>



<p>2.2 – 16 MPa</p> <p>Warning message about pressure in the hydraulic system</p>	 <p>2.5 – Use hearing protectors</p>	 <p>2.6 – Use protection goggles</p>
 <p>2.9 Do not exceed the maximum RPM</p>		

Table 1 Safety signs on the machine and their meaning

4. Intended use of the machine

The rotary mower is designed for agricultural applications, mowing of the low growing green forage like grasses, alfalfa, etc., on fields and meadows with flat surfaces.

It can be used in fields and meadows, which contain no stones, are flat or slightly undulating, with the slope of up to 10 °.

The mower is a machine suspended on the three-point hitch system of the category I and II tractor. The working elements are two rotating discs, fitted with blades. This unit is driven from power transmission shaft, through articulated telescopic shaft and belt transmission to bevel gears. The bevel gears are embedded on the drive shafts, which drive the discs.

Complying with the requirements related to the use of the machine, its operation, and repairs, strictly according to the manufacturer's guidelines, is the precondition of the use of the machine as intended. The machine should be used, operated, and repaired only by persons familiar with its specific characteristics, who have learnt the rules of conduct prescribed by the occupational health and safety regulations.

The distributor offers a wide range of agricultural machinery. It can also provide professional advice in terms of choosing the right equipment for your needs.



Any doubts concerning the machine's intended use should be resolved by contacting its distributor. Selection of the appropriate product and knowing the range of its intended use will contribute to the occupational safety.

Using the machine for any other purpose shall be considered contrary to the intended use.

5. Equipment and accessories

5.1. Basic equipment

Basic equipment of the mower consists of:

- User Manual together with Spare Parts Catalog and Warranty Card - 1pc.
- Special spanner - 1pc.
- Set of blades - for number see Table No. 2.
- Set of spare blades
- For BDR 210 – PTO shaft 460Nm L-860 and hydraulic cylinder -1pc.

Basic equipment of the mower does not include warning signs with lights, slow moving vehicle triangle, and articulated telescopic shaft. The above items can be purchased additionally from the distributor or at the machines' point of sale.

5.2. Technical characteristics

The overall construction of the mower is shown in the following figure.

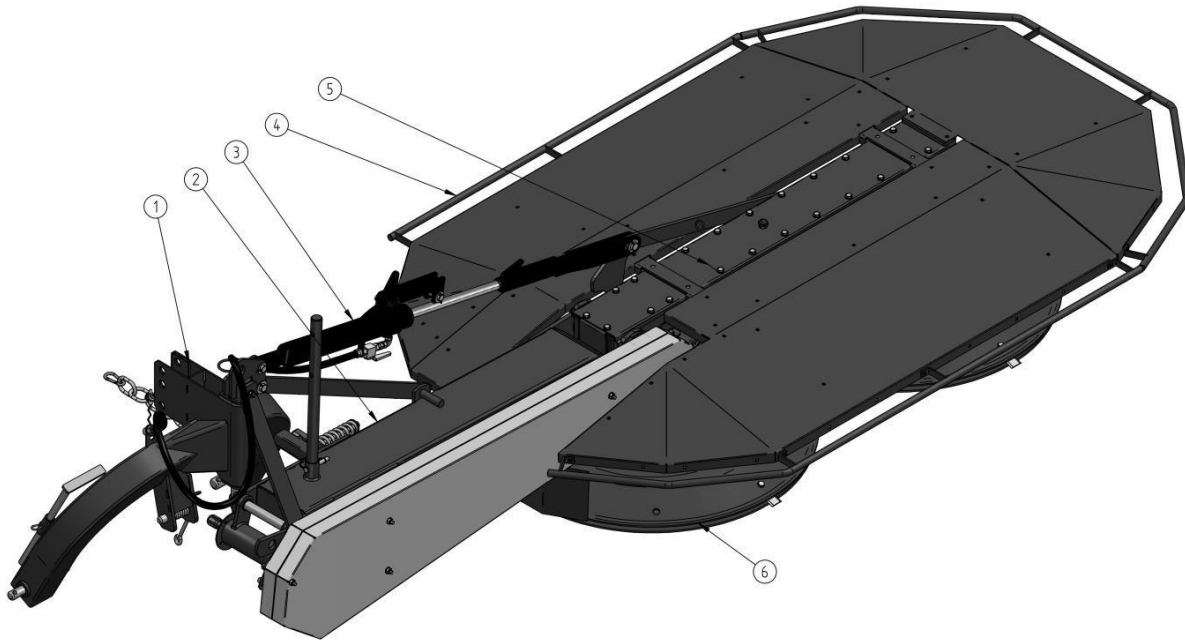

Figure 2 Overall machine construction: 1 - suspension frame; 2 – main chassis; 3 – hydraulic cylinder (depending on the model); 4 – cutting unit; 5 – cover assembly; 6 – working section of cutting unit. 7 – support foot.

Suspension system frame is used to connect the mower to a tractor. Through center frame, the suspension system frame is connected to the complete working unit with covers.

The working unit consists of two working drums, with cutting blades rotationally embedded in the lower part of the drums. Diagram of the drive system is shown in Figure 3.

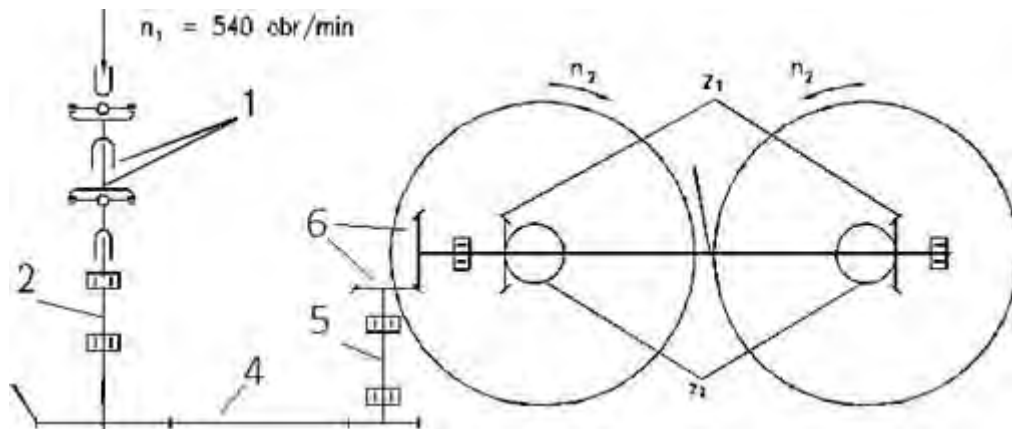

Figure 3 BDR 210 drive system diagrams: 1 – articulated telescopic shaft with one-way clutch; 2 – drive head shaft; 4 – V-belt transmission; 5 – main frame shaft; 6 – bevel gear; n_1 – rotational speed of tractors PTO; n_2 – rotational speed of drums (values given in Table 2); z_1 – large bevel gear; z_2 – small bevel gear.

The drums are driven by the tractors PTO shaft. Together with the blades, they rotate in opposite directions, cutting plants and forming green forage in a swath. The one-way clutch allows the drums to rotate freely after the engine is shut off, and it protects the driving elements from damage.

Technical-operational data for mowers are provided in Table 2 (below).

		UoM	Mower model	
		BDR	210	
No.		Type	2.10m	
		Symbol	Z-042/3	
1	Type of mower	-	Rotary suspended	
2	Mowing width	[m]	2.10	
3	Power requirement	[kW]	70	
4	Number of cutting drums	[pcs.]	2	
5	Number of blades	[pcs.]	8	
6	Standard cutting height	[mm]	40	
7	Low cutting height	[mm]	35	
8	Rotational speed of working drums	[rpm]	1545	
9	Rotational speed of tractor's PTO	[rpm]	540	
10	Recommended PTO	[cat.]	IV	
		[Nm]	460**	
11	Work efficiency	[ha/h]	Up to 2,5	
12	Working speed	(km/h)	8	
13	Transportation speed	[km/h]	15	
14	Transportation clearance	[m]	0.4	
Overall dimensions in transportation position (with covers assembled, vertical position)**				
	Model	[mm]	210	
15	Length	[mm]	2460	
16	Width	[mm]	1750	
17	Height	[mm]	3060	
Overall dimensions in working position (with shield covers assembly)				
18	Length	mm	1750	
19	Width	mm	4220	
20	Height	mm	1090	
21	Weight	kg	562	
22	Nominal pressure in the hydraulic system / for models with hydraulic cylinder	MPa	16	N/A

*with one-way clutch

** The overall dimensions may differ when aggregated with a particular tractor

Table 2 Mowers' technical-operational data

6. Machine usage

The manufacturer declares that the machine is fully functional. It has been inspected in accordance with the quality control procedures and approved for use. However, this does not relieve the user from the obligation to inspect the machine after its delivery.



Before every time the machine is used, its mechanical condition needs to be checked, and especially the condition of cutting unit, drive transmission system, hydraulic system, and guarding shields.

6.1. Mower assembly

The distributor delivers a complete mower with a cover of the cutting unit. Installation of the cutting unit cover must be done by the user or dealer.



Working without the cutting unit cover, or with the cover damaged or raised, poses a danger for an operator and for environment – Strictly prohibited.

Instructions for the cover unit installation are provided in the paragraph “13.2.8 Cover unit”.

6.2. Connecting the mower to a tractor

Make sure that the connecting parts of both, the vehicle, and the machine, are suitably adjusted to each other. In case of any doubt, always ask the vehicle or the machine distributor.



The mower should be connected with the tractor by means of a three-point hitch suspension system. During connection, the mower should be in transportation position.

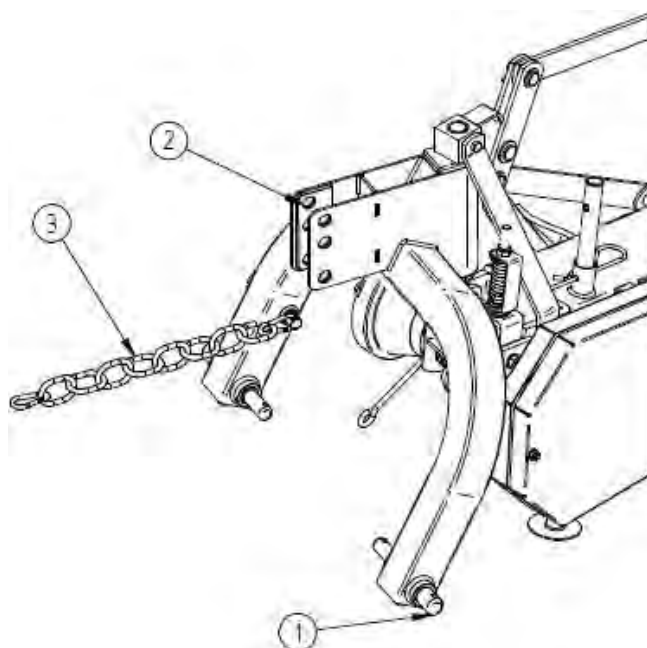

Figure 3 Aggregating – connecting the mower

In order to connect the mower to the tractor:

1. On the pins (Fig. 8, item1) of the suspension frame, fit the tractor's lower connectors (first the left side, then the right side), and be sure to secure them with lynch pins.
2. Insert the top connector's tip between the yoke plates, using the holes (Fig. 8, item 2), then connect with a pin and secure with a lynch pin.
3. Raise the mower to take the weight off the support foot.
4. Raise the support foot and secure it with a cotter pin.
5. Connect the chain to the transportation hitch or its bracket.

Adjust length of the articulated telescopic shaft to the tractor, according to the shaft's instructions.

6.3. Transport position

For the transportation of the unit, it should be set in the transportation position.

Articulated telescopic shaft must be detached from both the tractor and the mower.

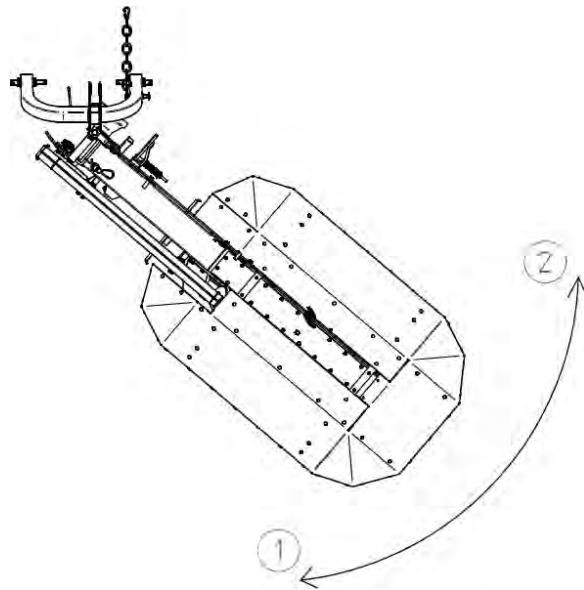

1) transport position 2) working position

For mower models with hydraulic cylinder 2.10m:

1. Park the tractor and mower on a flat, even surface,
2. Remove the securing element from the upper pivot of the suspension frame,
3. Raise the mower with a hydraulic cylinder of the tractor, so that the sliding discs do not rest on the ground,
4. Raise the support foot to the upper position, and secure with a cotter pin,
5. Manually place the mower in transportation position, so the interlock pin is inserted into the hole in clevis (rope must be loose) (Fig. 11A),
6. Bring the cylinder to transportation position, until the cylinder lock gets triggered (Fig. 13A). Transport position is shown in the Figure 13.

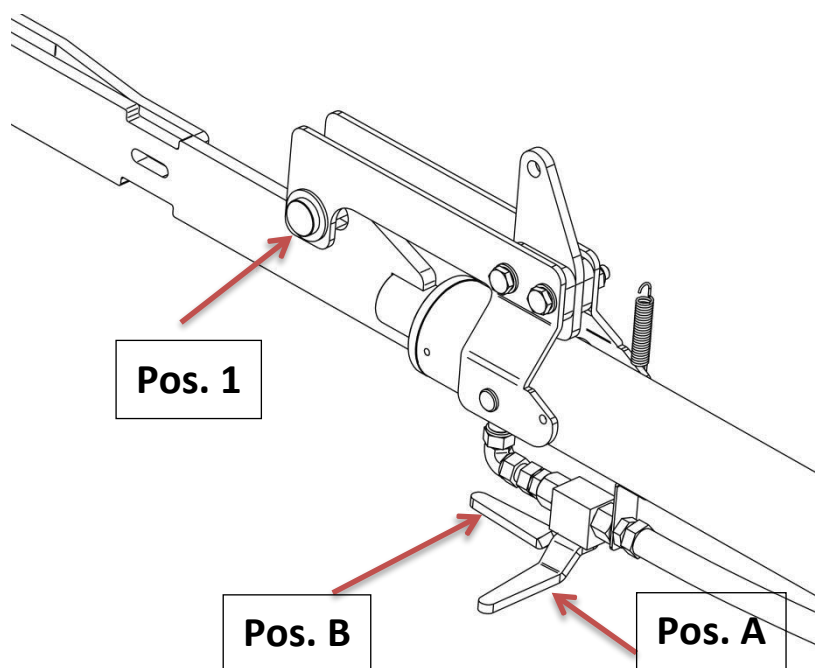

Figure 4 Proper transport position for 2.10m mowers

Closing the cylinder for BDR 210 mower for transport is shown in the figure below.

Lock pin - **Position 1** should lock into the cylinder handle (lower the mower until the pin is completely locked). The ball valve lever should be moved to the **closed position - Pos. A**.

However, for operation, the valve lever should be moved to the **open position – Position B**, and then open the lock with the cable until the lock is released.



6.4. Working position

To transform the transportation position to the working position:

1. Park the tractor and mower on a flat, even surface,
2. In the mower with hydraulic cylinder, pull the rope to release the cylinder lock then move the mower to horizontal position. When lowering the mower, you must exercise extreme caution.
3. Lower the mower just above the ground.
4. Standing at the rear of the machine, pull the rope and remove locking pin from the clevis, then rotate the mower to working position.
5. Mount a securing element on the top pivot of suspension frame, and then secure it with a cotter pin.

6.5. Adjusting the mower

After setting the mower in working position, the sliding discs should be positioned parallel to the ground.

In order to change the cutting height:

- 1) Position the mower for transportation and lift it to the upper position, immobilize the tractor, switch off its engine.
- 2) Secure the mower against falling off, additionally support one of the discs,
- 3) Unscrew the bolts (Fig. 17, item 1) and remove the sliding disc (Fig. 17, item 5)
- 4) Unscrew the bolts (Fig. 17, item 3) fixing the resistance disc (Fig. 17, item 2) and remove the disc.
- 5) Adjust the cutting height (Fig. 17, item 4 - spacer rings),
- 6) Assemble the parts in reverse order.

Execute the above steps on the second element of the cutter unit's working section.

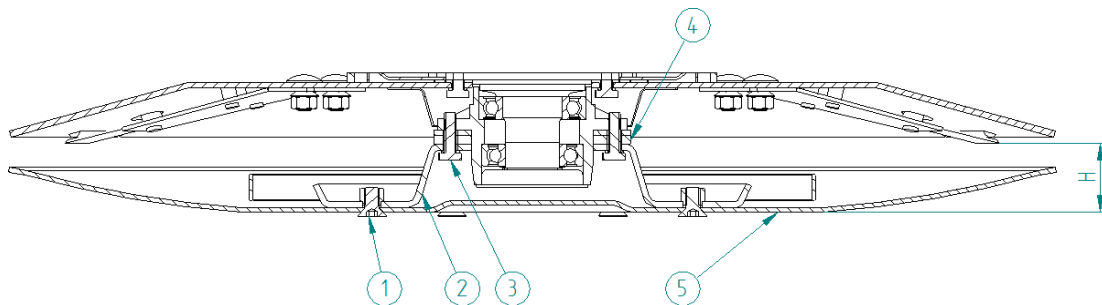
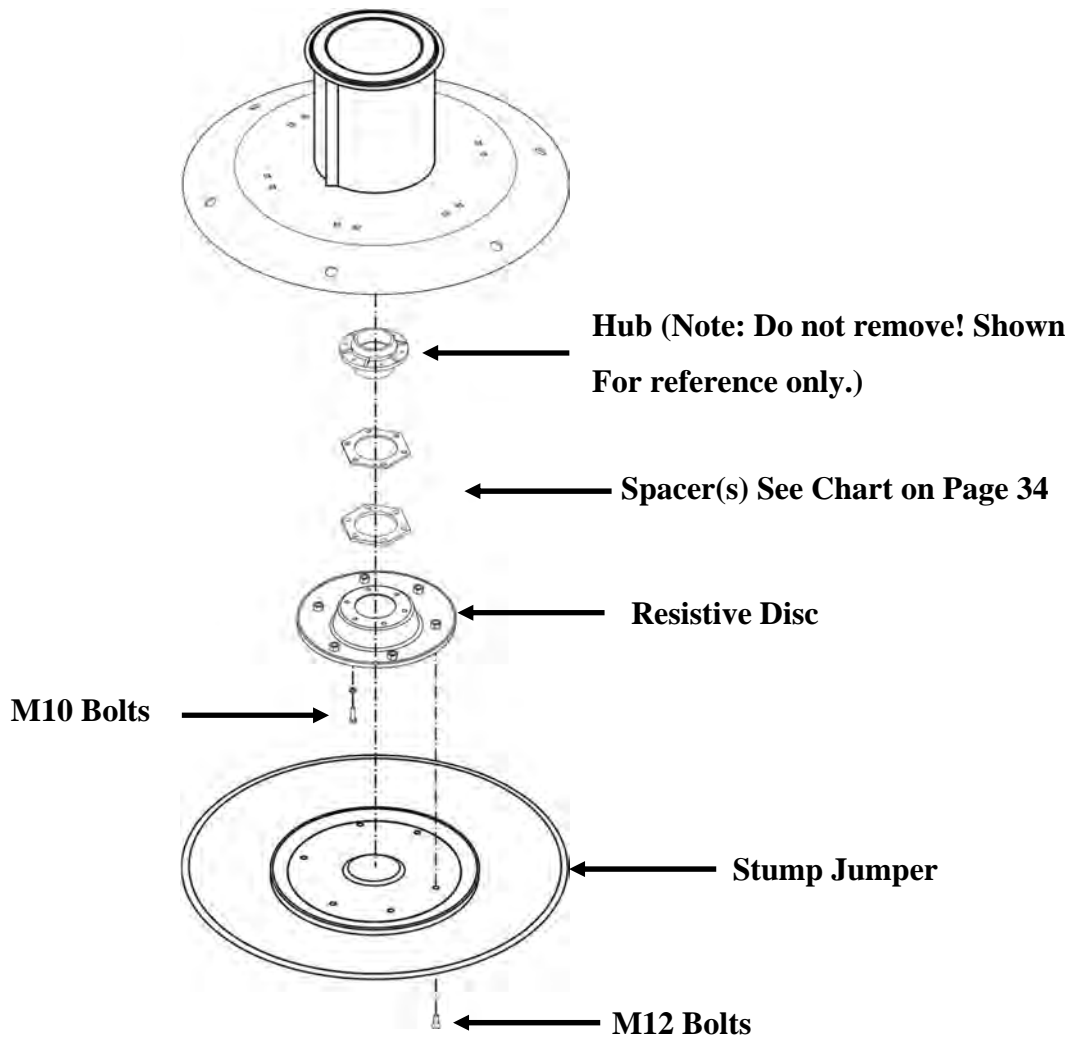

Figure 5 Cutting height adjustment: H- cutting height

Adjusting the height of cut.

1. To make height adjustments the following must be done:
2. Position the mower to the transport position and lift it to the upper position.
3. Set the tractor's handbrake and disengage the tractor's engine.
4. Secure the mower from falling with a chain and an additional support placed under one of the stump jumper disks.
5. Remove the M12 bolts securing the stump jumper to the machine.
6. Remove the M10 bolts securing the Resistive Disc to the machine.
7. Add or remove Spacer(s) to adjust the cut height. Refer to Chart on page 34 for correct spacers.
8. Re-assemble in the reverse order.
9. Repeat the above steps for the other Discs.



Model	Cutting Height in MM		Spacers Req'd.
BDR-210	Min.	35	None
	Standard	40	1 - 5mm spacer
	Max	45	2 - 5mm spacers

6.6. Operation of the mower

The mower is equipped with an overload break-back device, which allows pushing away the mower when it hits an obstacle or encounters too great resistance during cutting. To engage back the break-back device, reverse the tractor a short distance. Incorrect spring tension can cause incorrect operation of the machine, or even its damage.

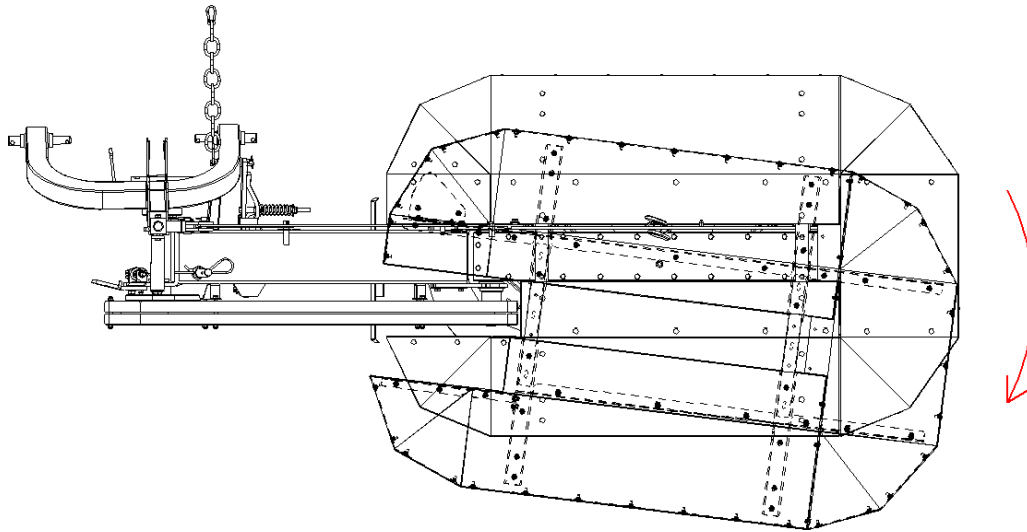

Figure 6 The mower pushed away after activation of break-back device

Construction of the break-back device is described in the paragraph “13.2.5.4 Break-back device”. The length of the tensioned spring must be adjusted, if required.

7. Operation and maintenance

All the machine operations can be performed by the operator of the vehicle, to which the machine is attached, providing that he/she has proper authorization to operate this vehicle.



After disconnecting the machine from a vehicle, it should be stored under shelter on a flat and hard surface, supported on its foot.

Before connecting the machine to a tractor, the operator must always check the condition of the machine and prepare it for commissioning. To do so, he/she should:

- Read carefully this manual and follow the guidelines contained herein,
- Learn and understand the operation of the machine,
- Perform visual inspection of all elements of the machine, looking for any mechanical damage,
- Lubricate the machine in accordance with the recommendations,
- Check the mechanical condition of the pins in the hitch system, and of the cotter pins.
- Check oil level in the gearbox,
- Check tension of the V-belts,
- Check condition of the bolted joints,
- Check condition of the cutting blades.



Use only the original spare parts provided by the distributor, to guarantee safe and reliable operation of the machine. The use of unoriginal spare parts or parts, which have been repaired, will void the warranty.

If all the above listed steps have been performed, and the mechanical condition of the machine does not raise any doubts, it can be connected to the tractor.

Aggregating of the machine with the tractor is shown in paragraph 6.2 Aggregating – connecting the mower.

7.1. Adjustment of the V-belts tension

The mower is equipped with a spring-loaded belt tensioner. Correct tension of the belts can be checked through the inspection hole (Fig. 21). Properly tightened belts should give in slightly under the pressure from the operator's hand.

In the event of damage to, or an overextension of even one of the belts, you must always replace the entire set of belts (using the belts with the same markings and the same brand).

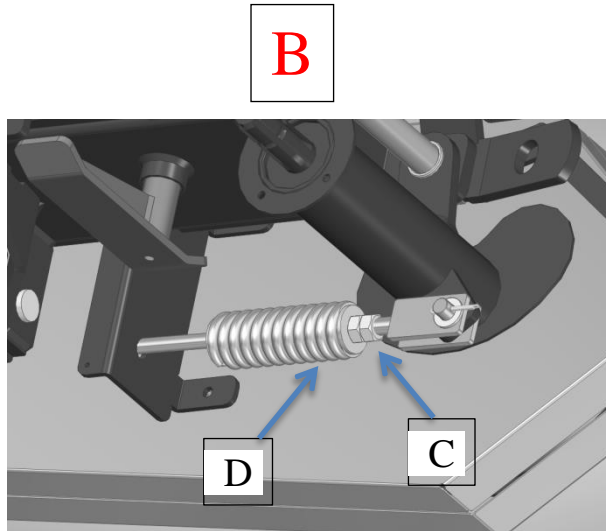
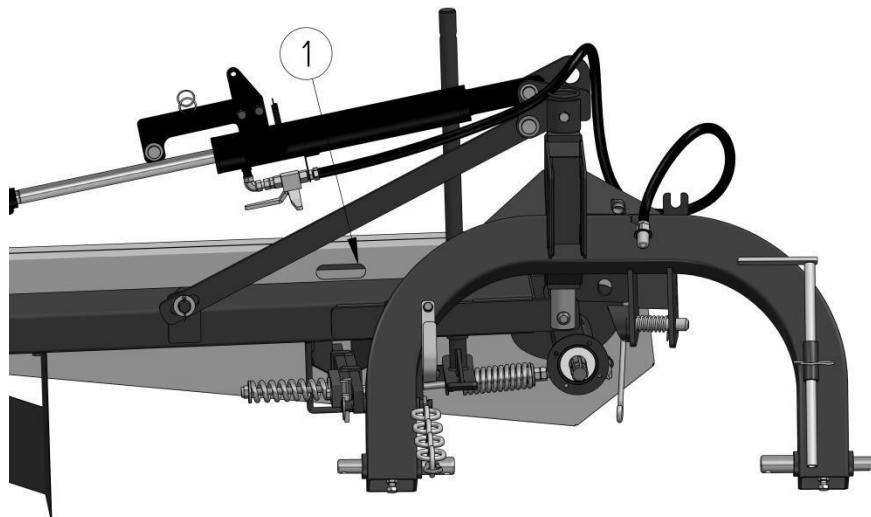

Figure 7 Adjustment of the V-belts tension: A) Belt tensioner B) for BDR 210 version

When adjusting the belt tension on the BDR-210 mower (Fig. 20 B), unscrew the lock nut (Fig. 20 - C), adjust the nut closer to the spring (Fig. 20 - D), then tighten the lock nut (Fig. 20 - C)



against lock nut "D".

Figure 8 Checking of the proper adjustment of V-belts tension: 1) inspection opening for checking the tension of the belts

7.2. Replacing the blades:

The cutting blades must be replaced in compliance with the specific safety rules:

1. Use only the original and functional parts for the cutting unit.
2. Each time the replacement must include the full set. You must remember about the uniform distribution of the rotating masses, to ensure the uniform wear of the blades.
3. Check the condition of the related components: holder, knife. Replace them with new ones if any damage occurs.
4. When tightening bolted joints observe the values in Table 3, to ensure appropriate tightening torque of screws and nuts.



Worn out or damaged parts must be replaced with new ones.

Working with damaged parts on the working disc, blade holders or blades, is strictly prohibited.



Inspection of the blades should be performed every time before you start working and after each instance of hitting an obstacle, e.g., stone, wood, metal. It is mandatory to wear protective gloves.

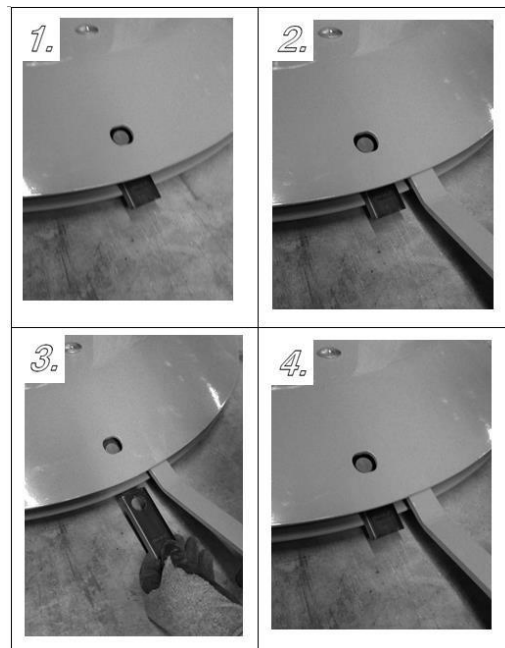

Figure 9 Replacing blades:

The replacement or turning of a blade must be done with the special wrench, according to Fig. 22. Insert the wrench between the working disc and the blade holder so that the edge of the wrench is placed above the blade's holder.

Pry up the holder up to the point where the blade can be removed.

After checking the blades and holders, install blades in the same spot or in the adjacent disc (rotating in the opposite direction), to determine that they are not damaged, or replace them with new ones, then release

the blade changing tool on the blade holder. After replacing the holders or blades, pay attention to their proper position on the particular discs, which is shown in the following figure.

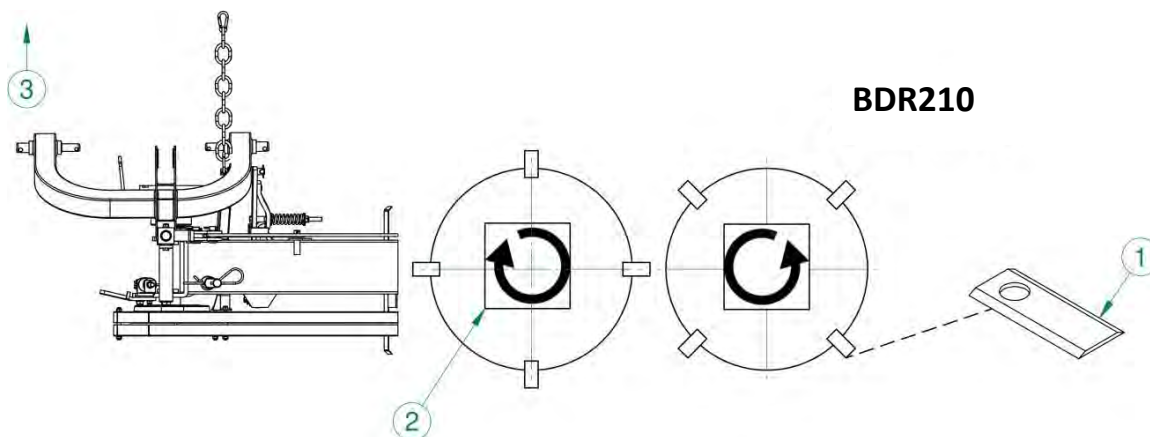

Figure 10 Diagram of the proper mounting of holders and blades on the working discs: 1) Cutting blade, 2) Direction of cutting discs rotation, 3) Direction of mowing

7.3. Maintenance after work

The machine should be always washed after mowing. **Wash the lower part of the working unit using pressure (holders, blades, resistance disc area)**, and park the machine on a flat, hard surface. Carry out an inspection of connections between the parts and units.

Damaged and or worn-out parts should be replaced with new ones. Check all the bolted joints, tighten the loose bolts and nuts according to Table 3.

Please note:

Distributor of the machine, Belco Resources Equipment, provides all spare parts.

Strength	6.8	8.8	10.9	12.9
Metric thread	Tightening torque [Nm]			
M5	4.5	5.9	8.7	10
M6	7.6	10	15	18
M8	18	25	36	43
M10	37	49	72	84
M12	64	85	125	145
M14	100	135	200	235
M16	160	210	310	365
M18	220	300	430	500
M20	310	425	610	710
M22	425	580	820	960
M24	535	730	1050	1220

Table 3 Tightening torque values for bolts and nuts.

It is also necessary to check the tension of V-belts, replace the damaged ones with new (always replace the whole set of belts). Adjust the whole set of new parts in accordance with the instruction - 7.1 Adjustment of the V-belts tension.

Lubricate the mower according to the instruction – 7.4 Lubrication.

All safety signs placed on the machine should be kept clean.

7.4. Lubrication



All maintenance and servicing works should be done with the switched off engine of the vehicle, released pressure and stopped rotations, and with both, the vehicle and machine, properly secured.



Avoid contact with oil!

Use the personal protective equipment: protective clothing, footwear, gloves, and goggles.



Articulated telescopic shaft should be operated and lubricated strictly according to the operating instructions provided by the manufacturer of the shaft.

To ensure proper operation of the gearbox:

- I) Every 10 hours check the oil level, using clean rod put into the oil fill opening (figure A below). The mower should be placed on a flat surface.
The oil level should be between min. 20mm to max. 30mm. measured from the bottom of the unit.
- II) Oil level should be additionally checked after every mowing season, and it should be refilled to the levels given below.
- III) **Oil does not require changing – only refilling unless it is contaminated . If the user wants to change the oil, old oil has to be sucked out through the refill plug on top. If grease is in the unit remove the top cover and scoop out the old. (Figure A)**

The required quantity of oil in the gearbox:

- A. 2.10m ~6 l

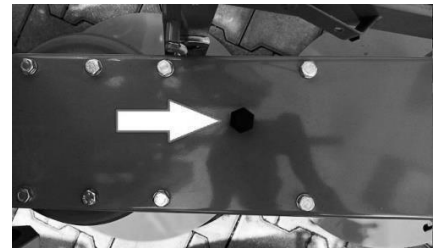

Figure A – oil fill plug

The machine manufacturer recommends using the oil: SP460 (based on 80W90) + admixture grease LT-43. In the event the oil level gets too low, find and repair the leak then fill in the required quantity.

7.5. End of season servicing

Includes all the tasks listed in the paragraph: 7.3 Maintenance after work. In addition, the machine should be stored under shelter, on a flat and hard surface and supported on its foot. Attention should be paid to the tightness of paint coat. In the event of paint losses, you must clean these spots and fill in the losses with the new coat of protective paint. V-belt tension in the off-season should be reduced (belts should be loose). Prior to commencing the next season's work, the belts must be properly tensioned again.



In the case of leaks from the hydraulic system, the damaged parts and components must be replaced to avoid contamination of the environment.

Hydraulic hoses, regardless of their external condition, must be replaced after 5 years.

7.6. Possible problems and solutions

Table 4 Possible problems and solutions

Problem symptoms	Problem cause	Possible solution
Increased vibration of mower	Unevenly worn out or damaged parts of cutting unit	Units with worn out elements replace with new complete sets
Bad cutting and clogging of the cutting unit	Dull or damaged blades	Replace dull or damaged blades with new complete sets Blades dull on one side only install on the disc with the opposite direction of
V-belts slippage	Poorly tensioned belts Belts are wet Belts are worn out Belts of unequal length	Check and adjust the belts tension Avoid mowing when it is raining Replace with new complete sets of belts Within one set of belts, there should be belts made by one manufacturer and bearing the same dimension
During normal operation, the cutting unit leans back, due to the action of the break-back device	Poorly tightened or damaged spring in the break-back device	Check and adjust the spring tension; replace if damaged
	Local bumps, e.g., hardened molehills	Reduce speed, and tilt the cutting unit backwards

8. Disassembly, disposal, and environment protection



Protect your hands (and body) against injuries, and the harmful effects of lubricants and oils.

Use protective gloves and tools which are in good mechanical condition.

Machine components, which when dismounting can move or rotate. Ensure that they are properly secured.

Worn or damaged parts removed during repair (disassembly) should be stored in a separate location, with a limited access for persons and animals. Worn out metal parts must be delivered to the scrap metal collection points. Worn out plastics must be delivered to the chemical waste collection points.

When filling up or replacing the oil, avoid spilling the oil. Store the waste oil in sealed containers, and periodically deliver it to the special collection points.



Abandoned parts or machine components, and spilled oil, may pose a risk of accident, cause an environmental pollution and violate applicable laws.

9. Spare Parts Catalog

9.1. *How to order spare parts*

Each order form should include the following:

- address of the buyer,
- exact shipping address (place where machine is located or other means for delivery collection),
- terms of payment,
- serial number and year of production of the mower (according to the plate located on the machine),
- spare part number,
- spare part name,
- number of parts ordered.



Spare parts must be ordered at the points of sale of the machines or from the distributor. Use only the original spare parts provided by the distributor to guarantee safe and reliable operation of the machine. The use of unoriginal spare parts or parts, which have been repaired, will void the warranty.

The manufacturer reserves its right to make changes in the construction of parts presented on the particular assembly drawings in this spare parts catalog. Such changes may not always be updated in the User Manual and in the spare parts catalog. Individual drawings may differ from the actual look of the parts.

Tar River Implements

401 Jeffrey's Road
Rocky Mount, NC 27804
sales@brglimited.com
www.BR-equipment.com

9.2. General construction – BDR 210 mower

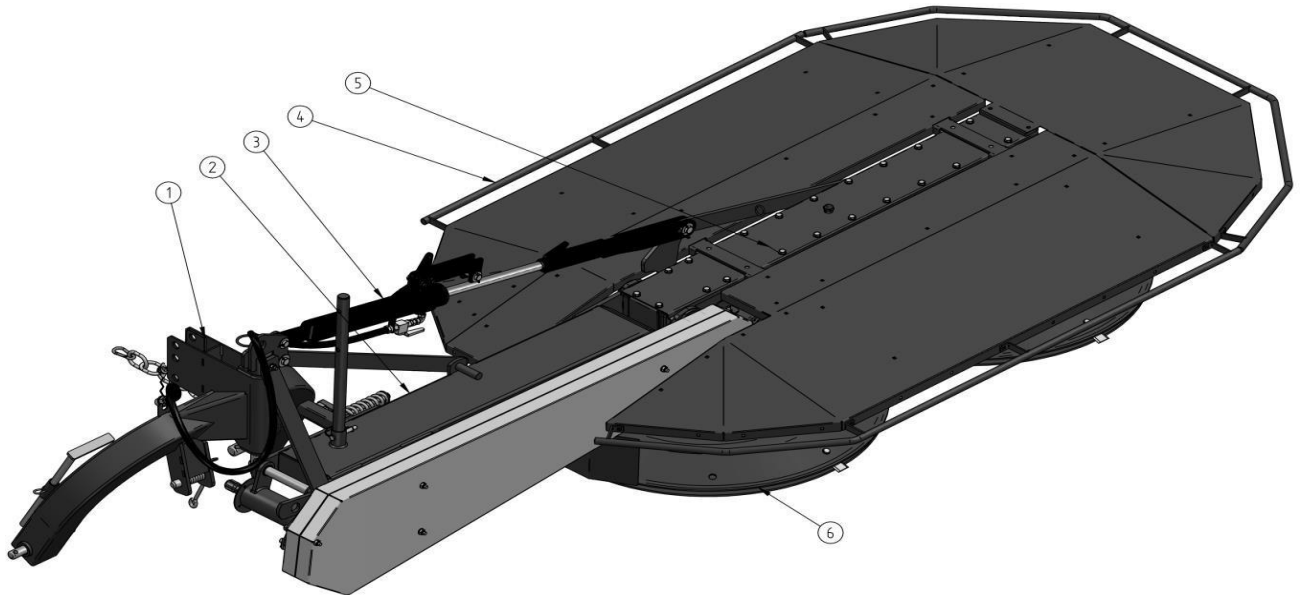

Pos.	Description	Index
1	Suspension system	9.3.1
2	Middle frame	9.3.2
3	Hydraulic system	9.3.3
4	Metal cover	9.3.4
5	Main frame	9.3.5
6	Cutting unit	9.3.6

9.2.1. Suspension system

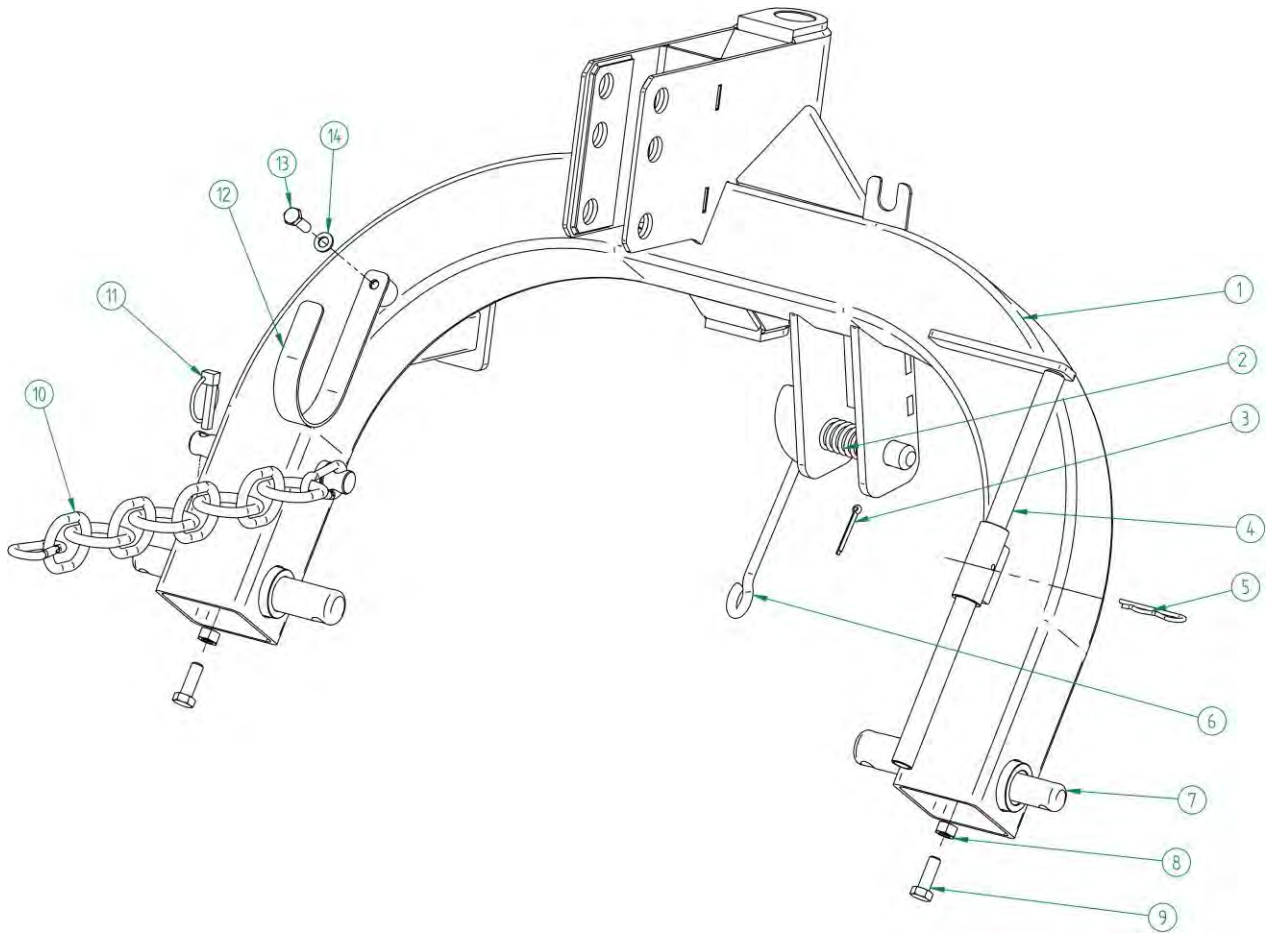

Pos.	PART NO.	Description	Quantity
1.	DM301011	Suspension Frame	1
2.	DMT0404	Hitch Lock Spring	1
3.	CP5x40	Cotter Pin- M5 x 40 GALV	1
4.	DM30104	210 Blade Removal Tool	1
5.	DM30105	R-Clip- M4 x 100 Double Pin	1
6.	DMT0403	Suspension Frame Latch	1
7.	DM30107	Lower Hitch Pin	2
8.	LNM12175	Self-locking Nut- M12 x 1.75 GALV	2
9.	BM1217535	Bolt- M12 x 1.75 x 35 8.8 GALV	2
10.	DM20274	Check Chain	1
11.	LYNPN10	Lynch Pin- M10	1
12.	DM30112	Shaft Holder	1
13.	BM101525	Bolt- M10 x 1.5 x 25 GALV 8.8	1
14.	LW10	Lock Washer- M10 GALV	1

*GALV= Galvanized Coating

9.2.1. Middle frame

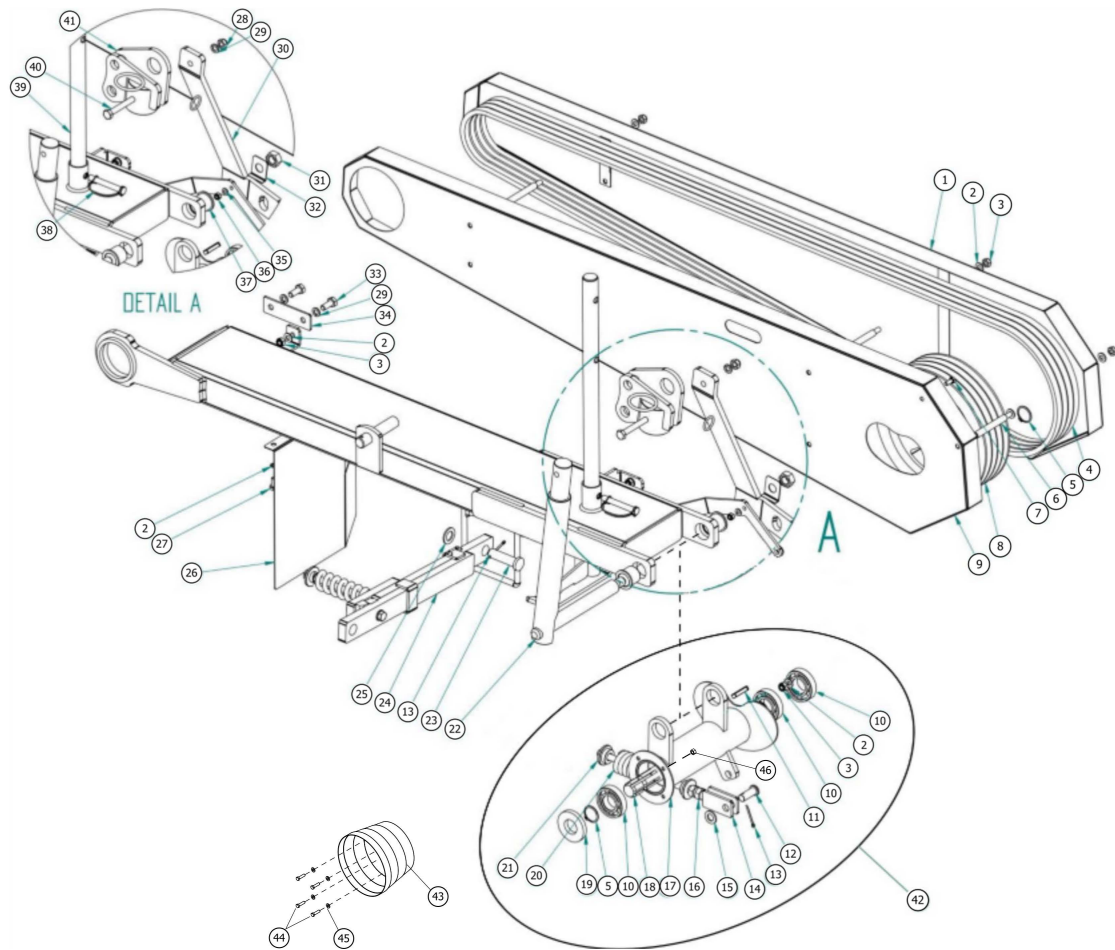

Pos.	PART NO.	Description	Quantity
1	DM30201	Outer V-belt Cover	1
2	FW10	Flat Washer- M10 GALV	14
3	LNLM1015	Self-locking Nut M10 GALV	10
4	SPB3550	V-belt- SPB 3550	4
5	SRE-35	Snap Ring- M35 (External)	2
6	DM30206	Cover Pin	5
7	BM0812520	Bolt- M8 x 1.25 x 20 GALV 8.8	1
8	DM30208	Large Pulley	1
9	DM30209	Inner V-belt Cover	1
10	B62072RS	Bearing- 6207 2RS	3
11	KM100850	Key- M10 x 8 x 50	1
12	DM83002	Pivot Pin- M16 GALV	1
13	DM30213	Pin- M4 x 50 GALV	2
14	DM302014	V-belt Tensioner	1
15	FW16	Flat Washer- M16 GALV	1
16	NM1620	Nut- M16 x 2.0 GALV	2
17	DM30217	Drive Head	1
18	DM30218	Head Shaft	1
19	OS357210	Oil Seal- M35 x 72 x 10	1
20	DM20241	Tensioner Spring	1
21	DM30221	Tensioner Spring Seat	2
22	DM30222	Joint Angular Axis	1
23	DM30223	Pivot Pin	1
24	DM30224	Safety Breakaway device	1
25	FW20	Flat Washer- M20 GALV	1
26	DM30226	Pilot Cover	1
27	BM101520	Bolt- M10 x 1.5 x 20 GALV 8.8	2
28	LNLM12175	Self-locking Nut- M12 x 1.75 GALV	1
29	LW12	Lock Washer M12 GALV	2
30	DM30230	Z-Joint	1
31	NM2015	Nut- M20 x 1.5 GALV tall	1
32	DM30232	Joint axis protection washer	1
33	BM1217535	Bolt- M12x35 GALV. 8.8 p.gw	2
34	DM150205	Rear Plate overlay	1
35	FW08	Flat Washer M8 GALV	1
36	LNLM08125	Self-locking Nut- M8 x 1.25 GALV	1
37	DM30237	Brass Bushing for Joint Axis	2
38	DM30238	Folding Pin- M12 x 67	1
39	DM30239	Jack Stand	1
40	BM12175100	Bolt- M12 x 1.75 x 100 GALV 8.8	1
41	DM30241	Hydraulic Head	1
42	P04008	Drive head complete	1
43	DM21903	PTO safety guard	1
44	BM0812520	Bolt HH M8-1.25 x 20 Galv.	4
45	FW08	Washer flat M08	4
46	LNLM08125	Nut self-locking M8-1.25	4

9.2.1.1. Safety Breakaway Device

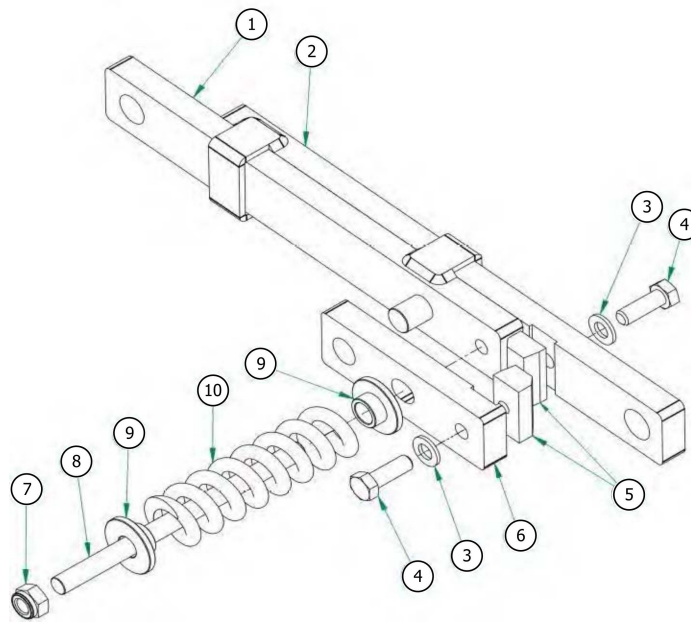

Pos.	PART NO.	Description	Quantity
1	DM30301	Inner Bar	1
2	DM30302	Outer Bar	1
3	FW12	Flat Washer- M12 GALV	2
4	BM1217535	Bolt- M12 x 1.75 x 35 GALV 8.8	2
5	DM30305	Breakaway Cube	2
6	DM30306	Flat Middle Bar	1
7	LNM142	Self-locking Nut- M14 x 2.0 GALV	1
8	DM30308	Spring Rod	1
9	DM30309	Spring Seat	2
10	DM20348	Tensioner Spring	1
11	DM30224	Safety Breakaway Device (Complete)	1

9.2.2. Hydraulic system

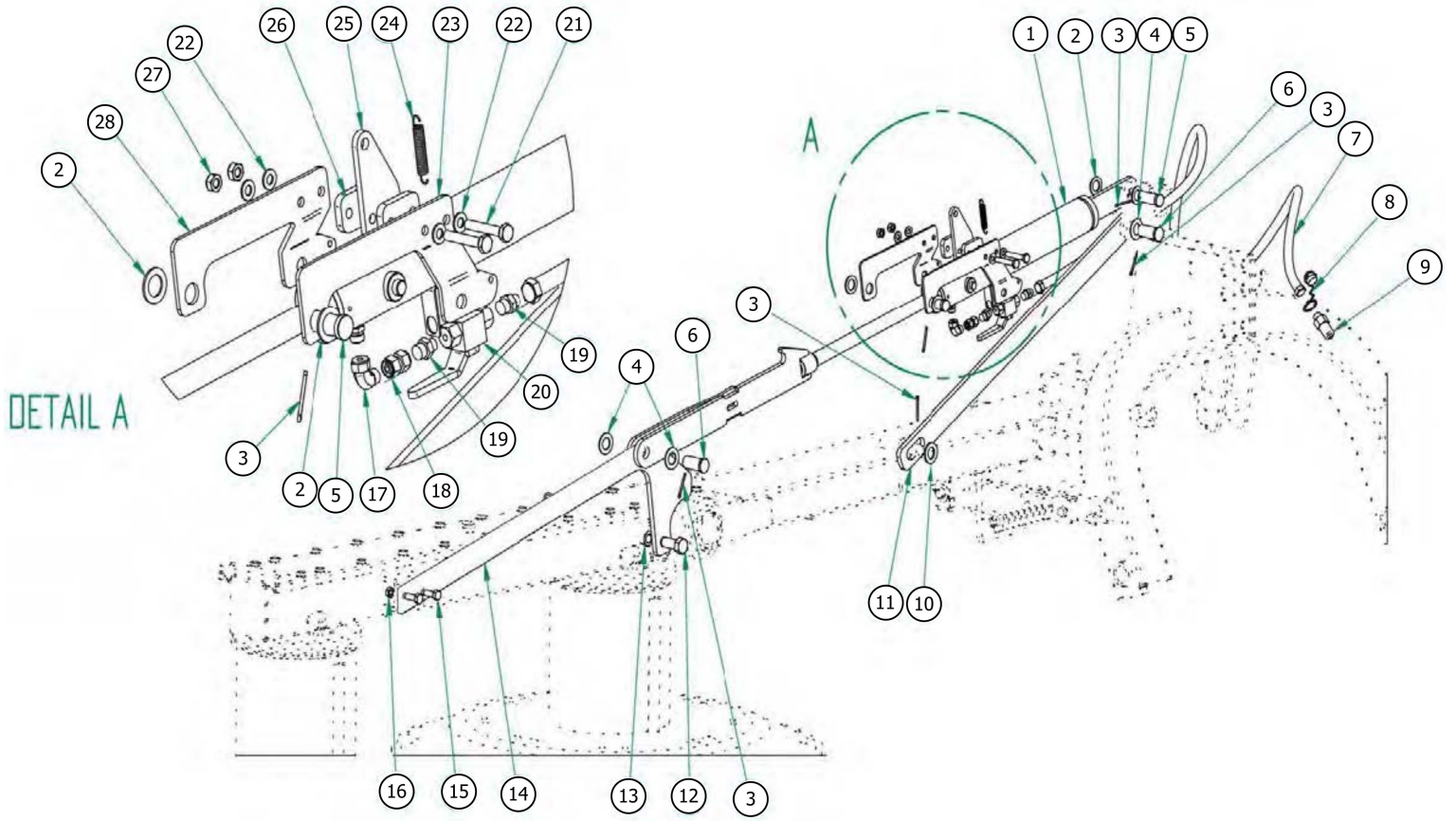

Pos.	PART NO.	Description	Quantity
1	DM30401	Hydraulic Cylinder for BDR210	1
2	FW22	Flat Washer- M22 GALV	4
3	CP5x40	Cotter Pin- M5 x 40 GALV	5
4	DM30404	Thin Flat Washer- M25 GALV	4
5	DM150074	Pivot Pin- M22 x 55 GALV	2
6	DM83002	Pivot Pin- M25 x 55 GALV	2
7	DM150331	Hose P51/P51 M18x1,5/M16x1,5 DN8 2SN L- 2500	1
8	DM30408	Hydraulic Plug Cover	1
9	DM130126	Quick Coupler ISO 12.5 M18 x 1.5 Euro Connector	1
10	FW26	Flat Washer- M26	1
11	DM30411	Metal Bar	1
12	BM202550	Bolt- M20 x 2.5 x 50 GALV 8.8	1
13	LMN2025	Self-locking Nut- M20 x2.5 GALV	1
14	DM30414	Metal Bar- Hydraulic Side	1
15	BM1217535	Bolt- M12 x 1.75 x 35 GALV 8.8	2
16	LMN12175	Self-locking Nut- M12 x 1.75 GALV	2
17	DM30417	Elbow fitting AB M16x1,5/M16x1,5 10L/10L	1
18	DM30418	Connector AA M16x1,5	1
19	DM30419	Connector A G1/4-M16x1,5 10L	2
20	DM30420	Ball Valve 2/2 1/4	1
21	BM101522	Bolt- M10 x 1.5 x 55 GALV 8.8	2
22	FW10	Flat Washer- M10 GALV	4
23	DM30423	Cylinder Lock	1
24	DM30424	Tension Spring- M1.5 x 12 x 75 GALV	1
25	DM30425	Cylinder Lock – tin 2	1
26	DM30426	Cylinder Lock - tin 3	2
27	LMN1015	Self-locking Nut- M10 x 1.5 GALV	2
28	DM30428	Cylinder Lock	1

9.2.1. Metal cover

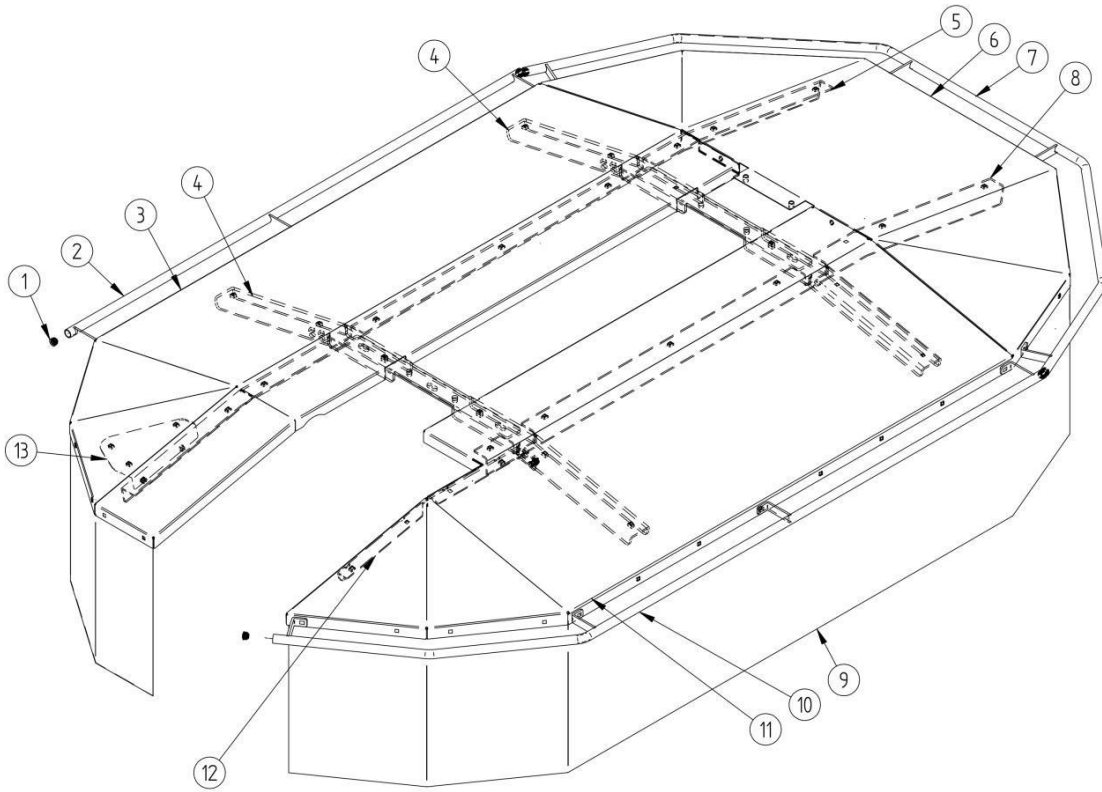

Pos.	PART NO.	Description	Quantity
1	DM30501	Plastic Protection Cover- M19 0.8-2.0	6
2	DM30502	Right Safety Guard	1
3	DM30503	Right Safety Cover	1
4	DM30504	Reinforcement Plate	2
5	DM30505	Reinforcement Bracket 2	1
6	DM30506	Rear Protection Cover	1
7	DM30507	Rear Safety Guard	1
8	DM30508	Reinforcement Bracket	1
9	DM30509	Debris Safety Tarp 2.1	1
10	DM30510	Left Protection Guard	1
11	DM30511	Left Safety Cover	1
12	DM30512	Reinforcement Mount	1
13	DM30513	Right Joint Cover	1

9.2.2. Main frame

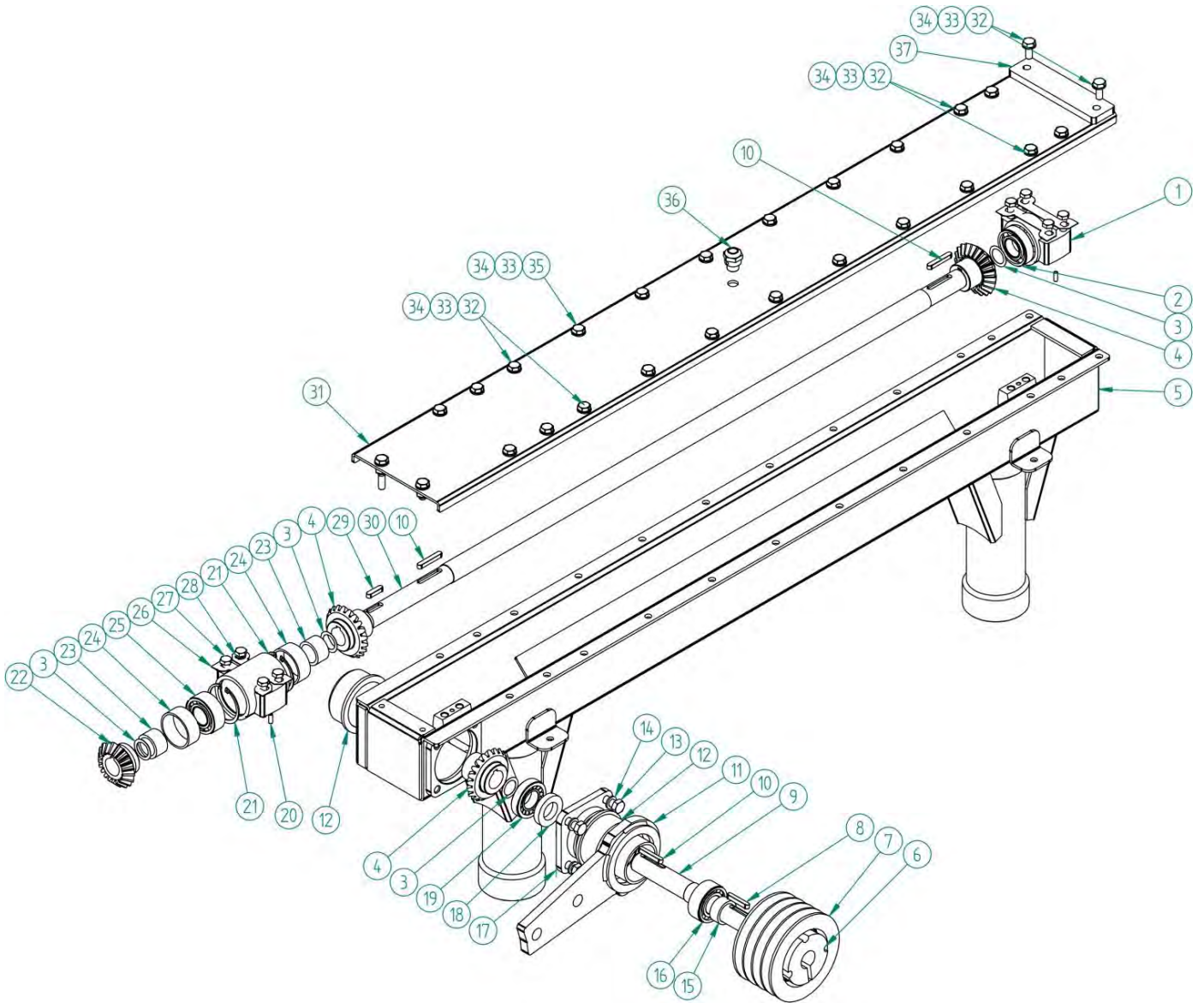

Pos.	PART NO.	Description	Quantity
1	DM10075	Small Bearing Housing	1
2	B6206	Bearing- 6206	1
3	DM30603	Adjustment Washer- M30 x 42	As needed- 0.3mm 0.5mm or 1mm
4	DM30604	Large Conical Gear- 21T	3
5	DM30605	Main Frame	1
6	DM30606	Pulley SPB 140	1
7	DM30607	Bushing- TB 2517/30	1
8	KM080745	Key- M8 x 7 x 45	1
9	DM30609	Small Pulley Shaft	1
10	KM080750	Key- M8 x 7 x 50	3
11	DM10180	Rear Plate with ring	1
12	DM10177	Thick Support Bushing	2
13	BM1212530	Bolt- M12 x 1.25 x 30 GALV 8.8	4
14	LW12	Lock Washer- M12 GALV	4
15	DM30615	Spacer Sleeve	1
16	B32062RS	Bearing- 3206 2RS	1
17	DM30617	Small Pulley Shaft Hub	1
18	OS305210	Oil Seal- M30 x 52 x 10	1
19	B30206	Bearing- 30206	1
20	DM85023	Split Pin- M6 x 16	4
21	SRI-62	Snap Ring- M62 (Internal)	2
22	DM30622	Small Conical Gear 18T	1
23	DM30623	Bushing 2	2
24	DM30624	Bushing 1	2
25	B3206	Bearing- 3206	1
26	DM10088	Tab Washer- 5042/01-062	4
27	BM101560	Bolt- M10 x 60 GALV 8.8	8
28	LW10	Lock Washer- M10 GALV	8
29	KM080732	Key- M8 x 7 x 32	1
30	DM30630	Frame Shaft	1
31	DM30631	Gearbox Cover	1
32	BM101525	Bolt- M10 x 1.5 x 25 GALV	20
33	BM101520	Bolt- M10 x 1.5 x 20 GALV	26
34	LNM1015	Self-locking Nut- M10 x 1.5 GALV	24
35	BM1217530	Bolt- M12 x 1.75 x 35 GALV	6
36	DM10441	Valve Set	1
37	DM30637	Rear Cover Washer	1

9.2.1. Cutting unit – working part

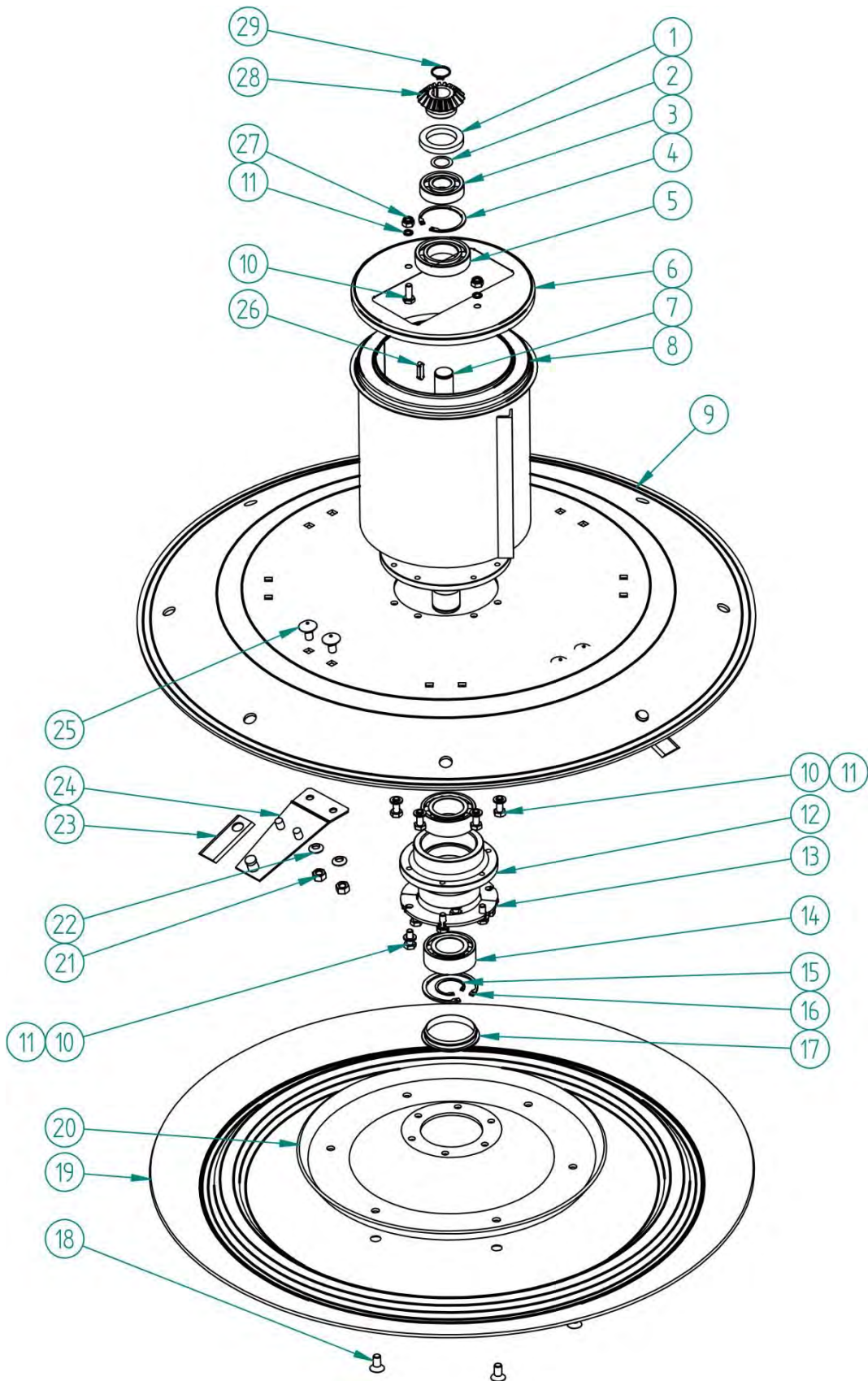

Pos.	PART NO.	Description	Quantity
1	OS507210	Oil Seal- M50 x 72 x 10	2
2	DM30702	Adjustment Spacer Shim- M30 x 42	As needed, M0.3, 0.5 or M1
3	B63062RS	Bearing 6306 2RS	2
4	SRI-72	Snap Ring- Internal- M72	2
5	B62102RS	Bearing 6210 2RS	2
6	DM30706	Cover	2
7	DM30707	Vertical welded shaft	2
8	DM30708	Drum cover	2
9	DM30709	Operating Disc	2
10	BM101525	Bolt- M10 x 1.5 x 25 GALV 8.8	32
11	LW10	Lock Washer- M10 GALV	32
12	DM30712	Lower Disc Hub	2
13	DM30713	Height Spacer Washer #5	4
14	B32092RS	Bearing- 3209 2RS	2
15	SRE-45	Snap Ring- M45 (External)	2
16	SRI-85	Snap Ring- M85 (Internal)	2
17	DM150031	Bottom Protective Cover	2
18	SSM1217525	Socket Screw- M12 x 1.75 x 25 8.8 GALV	12
19	DM30719	Stump Jumper- 210	2
20	DM30720	BDR 210 Resistive Disc	2
21	NM120175	Nut- M12 x 1.75 GALV	16
22	DM150030	Conical Ring	16
23	DM10454L	Blade- Long Version	16
24	DM37024	Blade Holder	8
25	CBM1217525	Carriage Bolt- M12 1.75 x x25 GALV 10.9	16
26	KM080732	Key- M8 x 7 x 32	2
27	LNM1015	Self-locking Nut- M10 x 1.5 GALV	4
28	DM30622	Small Conical Gear- 18T	2
29	SRE-30	Snap Ring- M30 (External)	2

Fitting instructions for the metal covers

Attention!

All bolted joints in steps I - VII should be initially only loosely connected - not tightened. The final tightening should be done after the cover has been placed on the main frame and adjusted to the machine - step XI of the covers fitting procedure.

1) Step I

- Find a safe and stable place to fit the covers,
- Lay out the left and right covers, and the bent reinforcements,
- **Make sure that the selected holes (Fig. 24, Detail A) are facing the correct way (the same direction).**

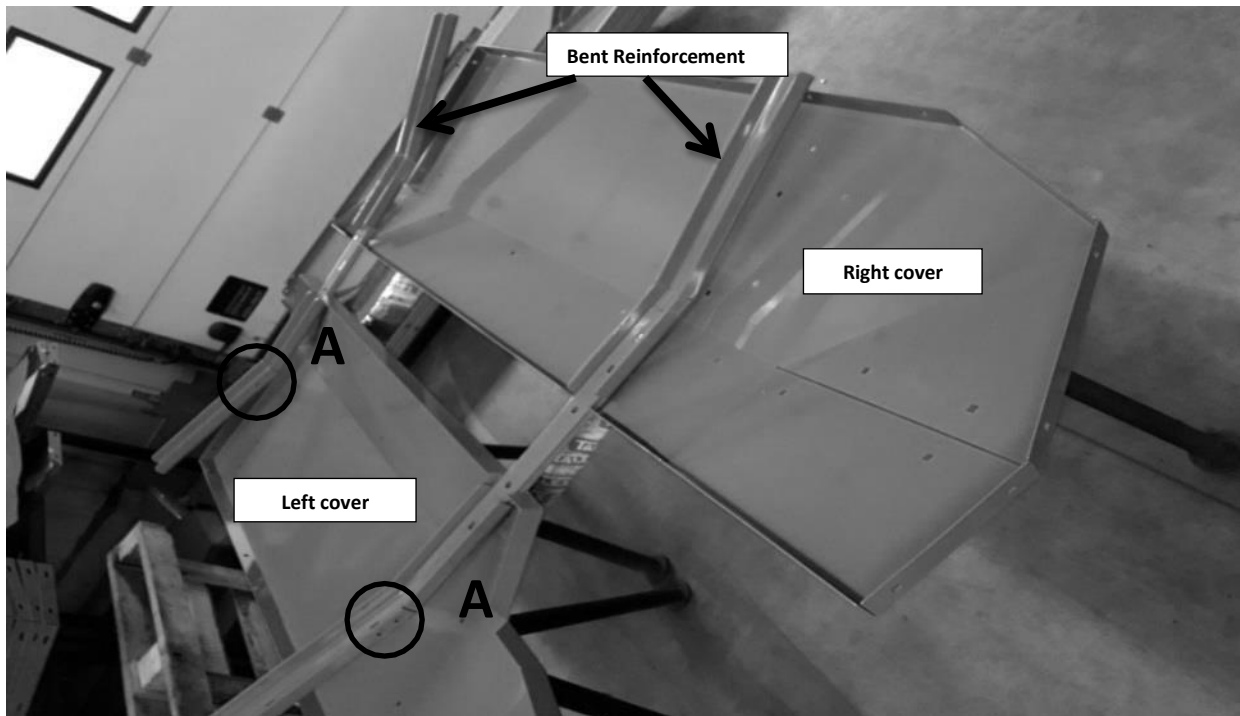
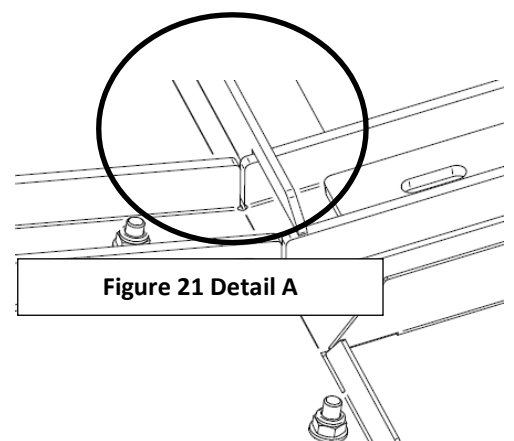

Figure 11 Step I of the tarpaulin covers assembly



1) STEP II

- Fix bent reinforcements to left and right cover

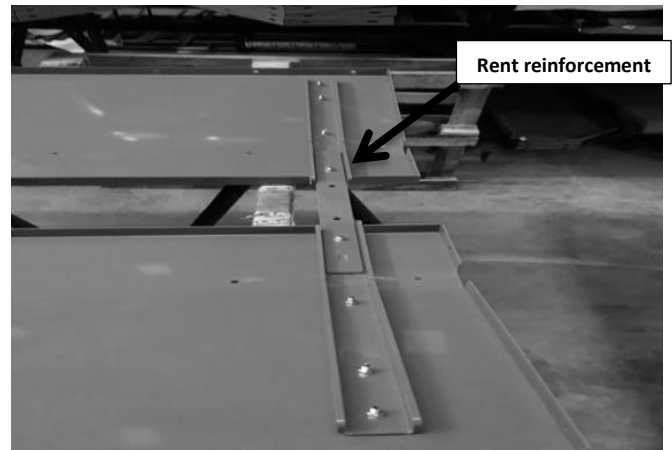

Figure 13 Step II Bent Reinforcement Assembly

The figure below shows which bolt elements were used in steps II to V. Case of use of other bolt elements, indicated below.

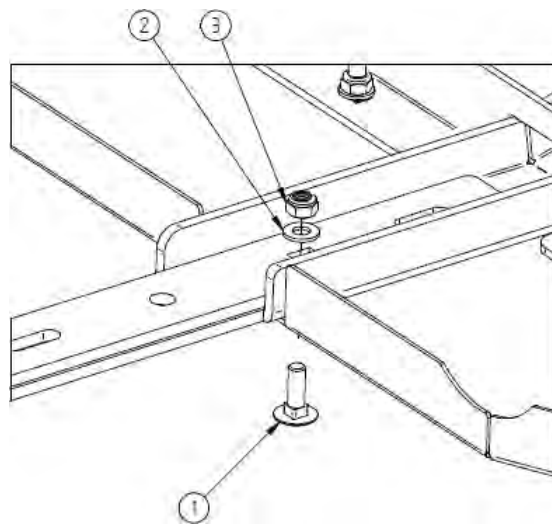

Figure 14 Bolted joint

Item No.	Name	PART NO.
1	Carriage Bolt- M8 x 1.25 x 25-8.8 GALV	CBM0812520
2	Flat Washer- M8 GALV	FW08
3	Self-locking Nut- M8 x 1.25 GALV	LNM08125

*GALV – galvanized coating

2) STEP III

- Adjust and fix reinforcing angle bars to the left and right covers

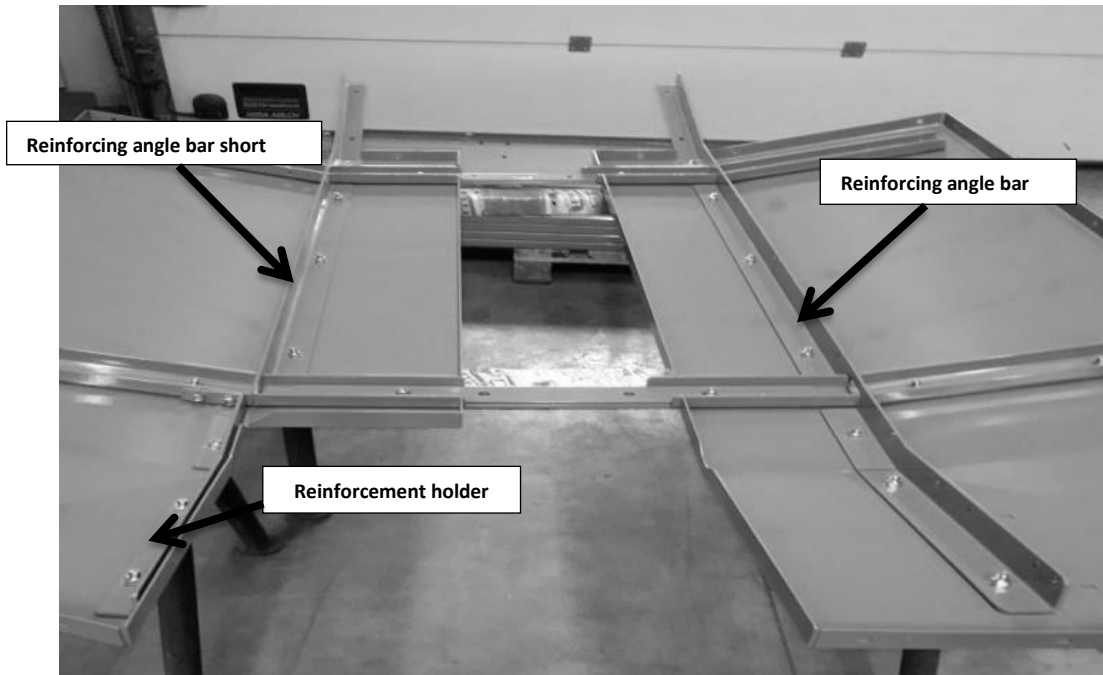
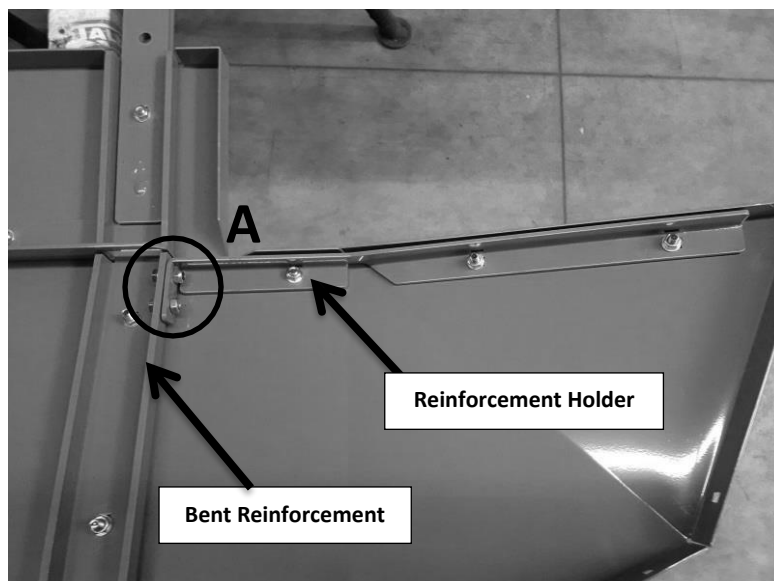
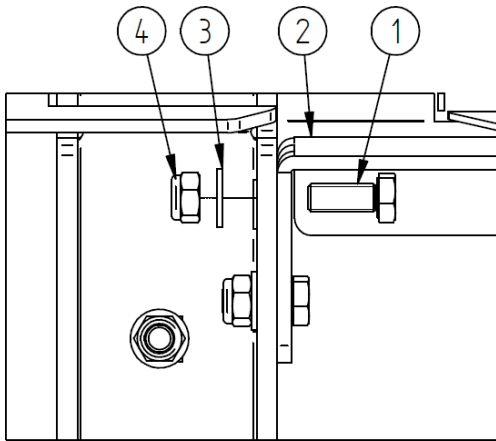

Figure 15 Step III Reinforcing angle bars assembly

3) STEP IV

- Adjust and fix the reinforcing holder to the holes in the left bent reinforcement and the left cover





Pos.	PART NO.	Name
1	BM0812520	Bolt- M8 x 1.25 x 25- GALV 8.8
2	DM30902	Reinforcement Holder
3	FW08	Flat Washer- M8 GALV
4	LNMO8125	Self-locking Nut- M8 x 1.25

Figure 16 Step IV Reinforcement holder assembly

*GALV – galvanized coating

Figure 17 Detail A of Figure 25

4) STEP V

- Adjust and fix the connection of the right cover to the holes in the right cover and the right-angle bar reinforcement,
- To connect with the angle bar (Fig. 31) use (Fig. 32):



Figure 18 Step V Right cover connection

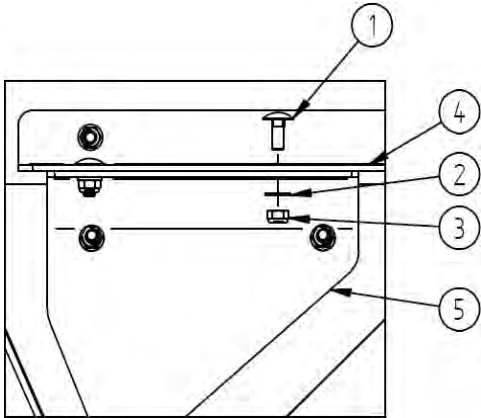

Pos.	PART NO	Name
1	CBM0812520	Carriage Bolt- M8 x 1.25 x 20- GALV 8.8
2	FW08	Flat Washer- M8 GALV
3	LNLM08125	Self-locking Nut- M8 x 1.25
4	DM31004	Reinforcement Angle Bar
5	DM31005	Right Cover Reinforcement

*GALV – galvanized coating

Figure 19 Detail A of Figure 27

5) STEP VI

Adjust and fix the rear cover to the left and right covers, and to angle bars.

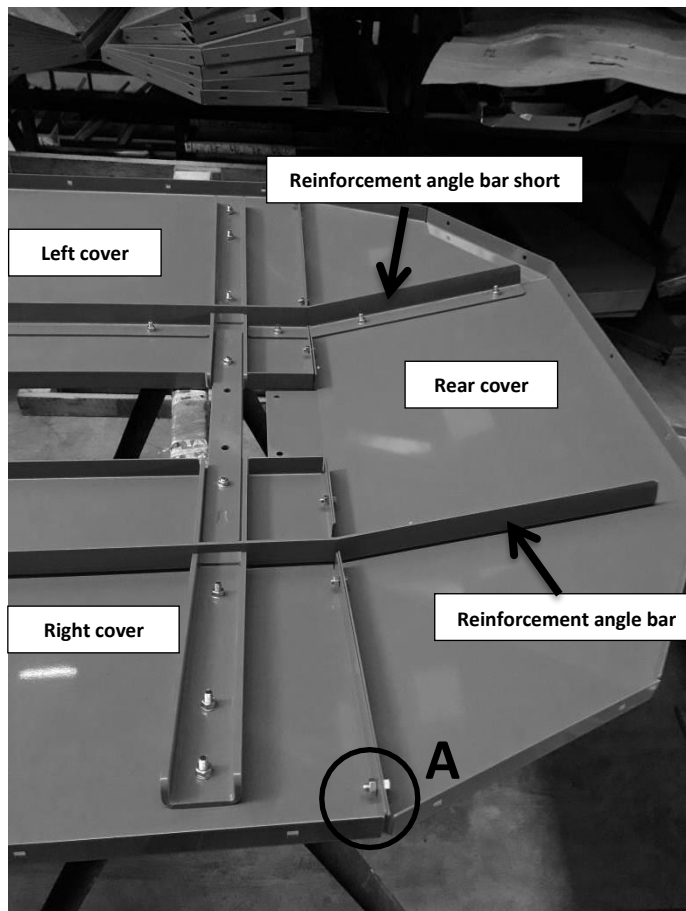
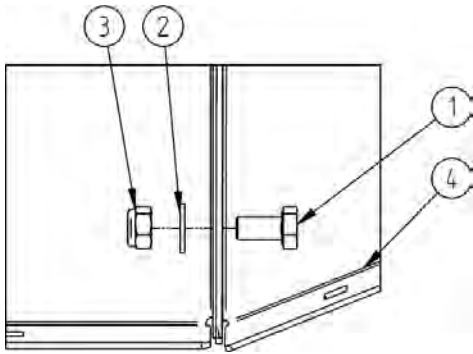

Figure 20 Step VI Rear cover assembly



*GALV – galvanized coating

Pos.	PART NO	Name
1	BM0812516	Bolt- M8 x 1.25 x 16-GALV 8.8
2	FW08	Flat Washer- M8 GALV
3	LNM08125	Self-locking Nut- M8 x 1.25
4	DM31104	Rear Cover

Figure 21 Figure 29 Detail A

6) STEP VII

Check if all the elements were properly fixed.

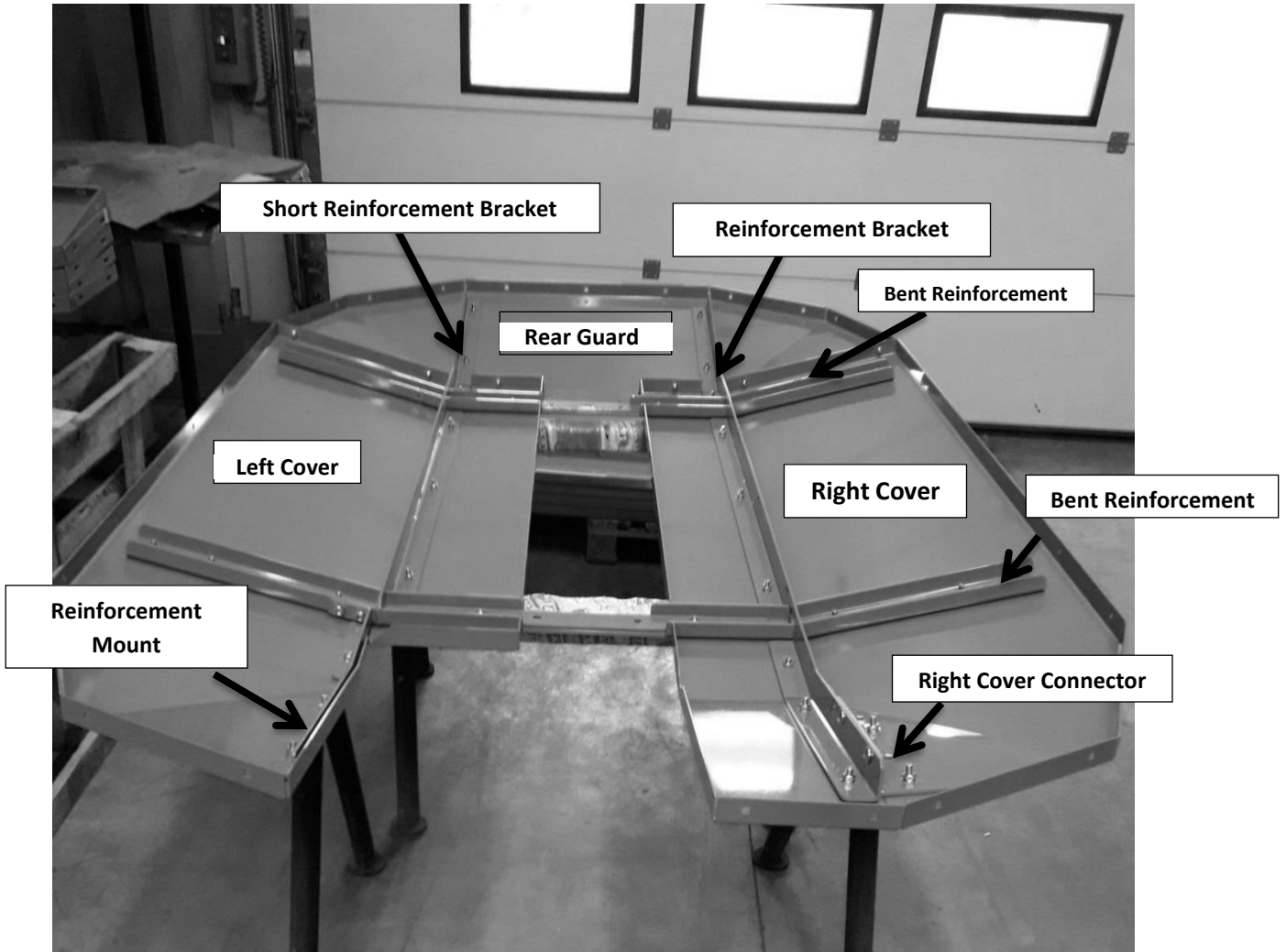

7) STEP VIII

After initial attaching of the apron to the metal shield, **bolt the apron together with the barriers to the metal guard** in places marked in **Figure 38 (below)**.

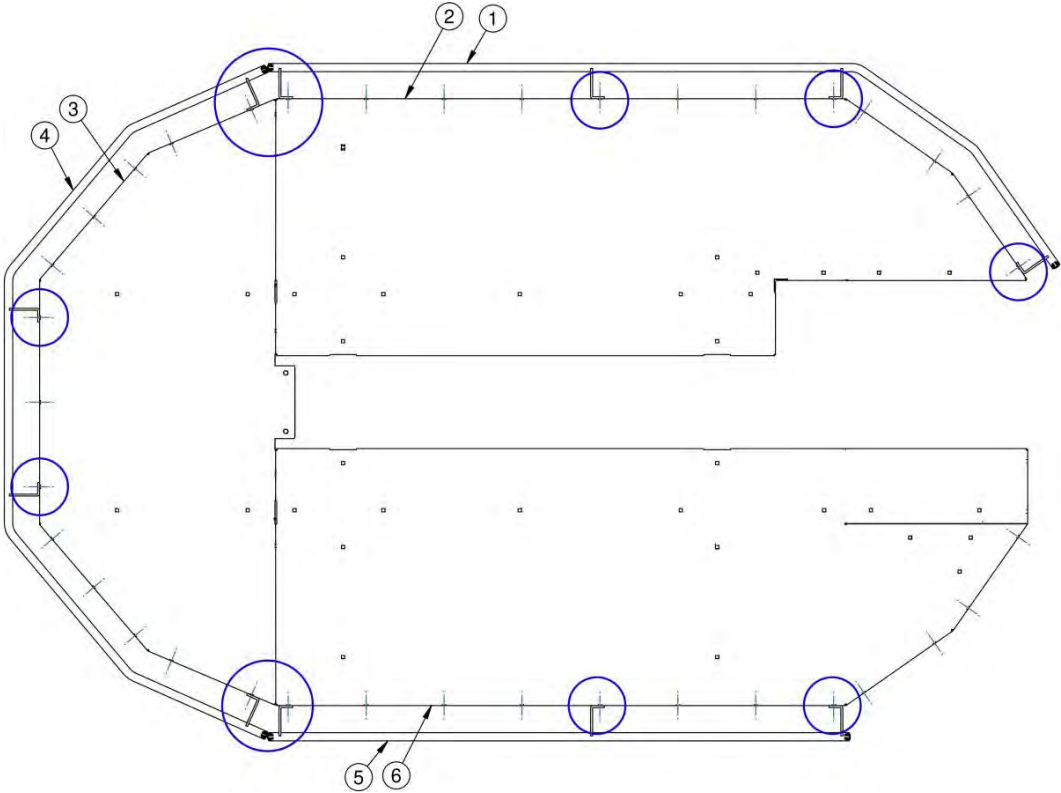

Figure 38 Metal Guard assembly for BDR 210

Pos.	PART NO	Description	Qty.
1	DM30510	Left Protection Guard	1
2	DM30511	Left cover	1
3	DM30506	Rear cover	1
4	DM30507	Rear Protection Guard	1
5	DM30502	Right Protection Guard	1
6	DM30503	Right cover	1

Attention! In the case of bolted joints fixing protective apron to metal cover, tighten the bolted joints according to Table 3.

8) STEP IX

- Disconnect the milled connector from the scythe-connector (For models with hydraulic cylinder) (Fig. 37 item 2),
- Unscrew the mounting bolts fixing the scythe-connector to the main frame (Fig. 37, item 1) and the scythe-connector remove tie rod-knife from the machine.

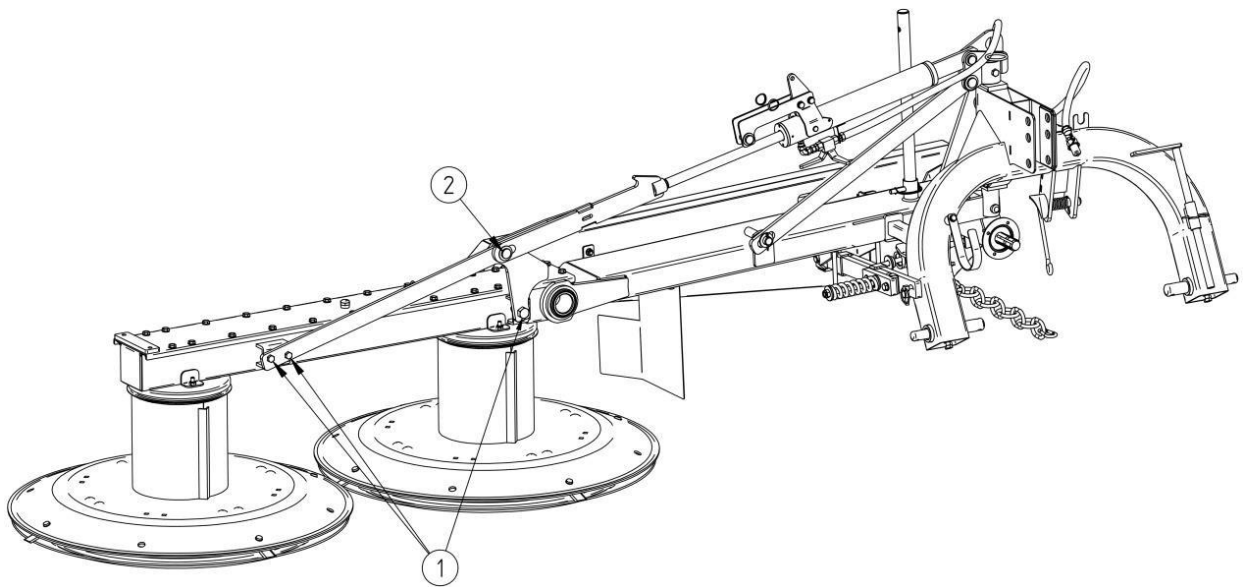

Figure 37 Cover assembly – STEP IX

9) STEP X

Unscrew the bolts indicated in the following figure (Fig. 39) - cover mounting location:

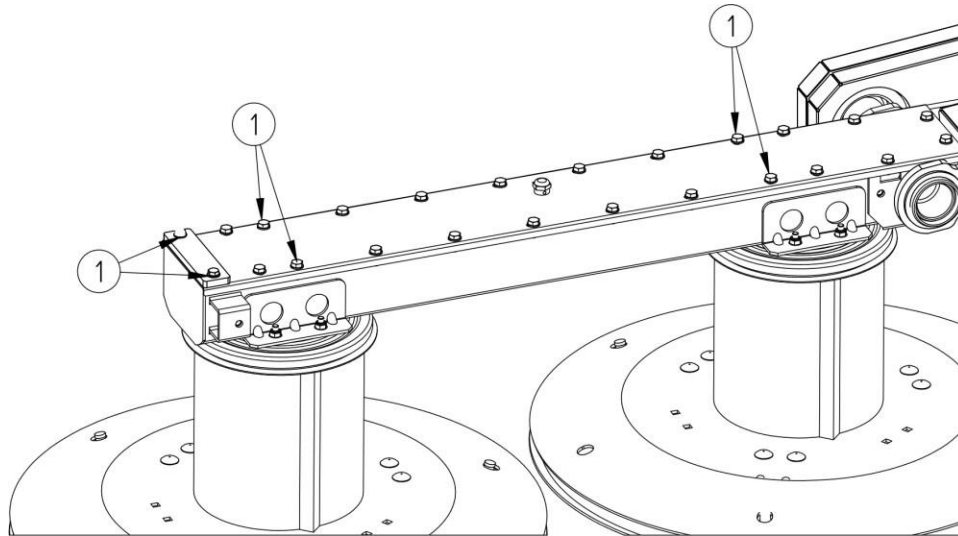
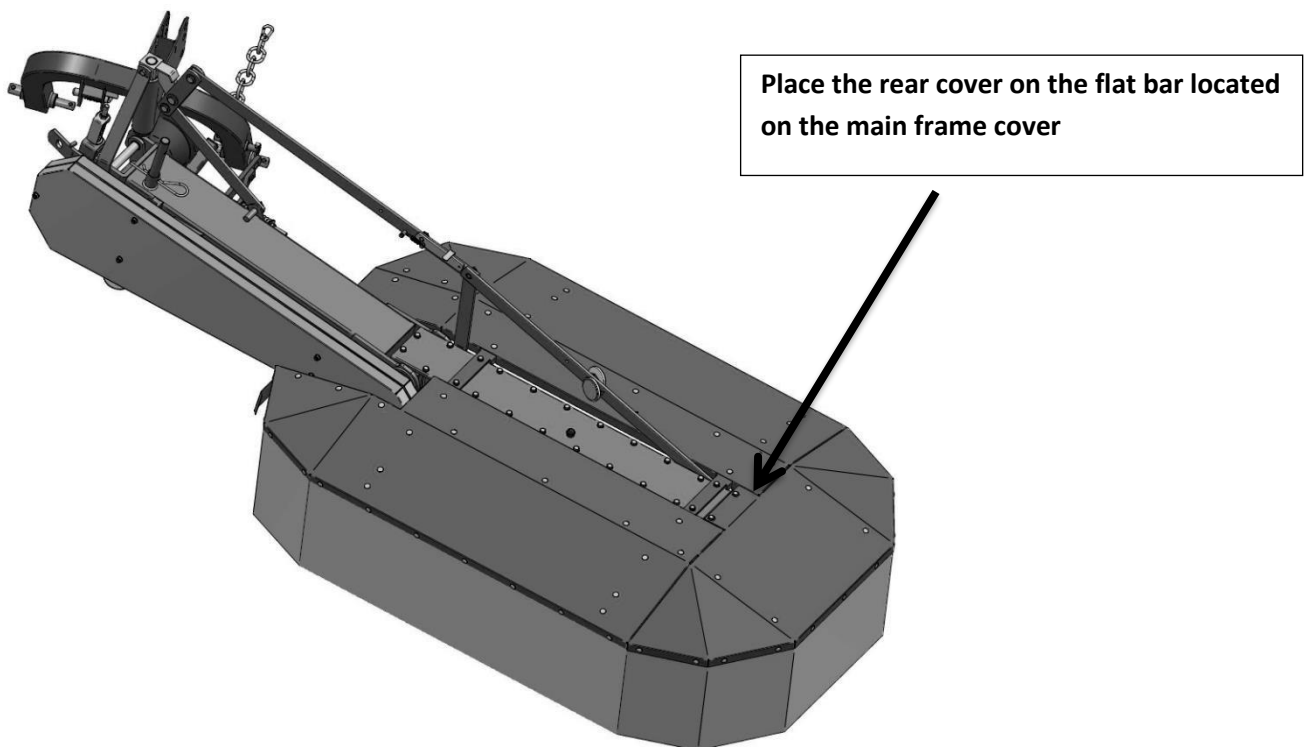

Figure 39 Metal covers assembly – STEP X

10) STEP XI

Adjust the cover to the "free holes" from STEP X and fix it with the bolt elements used in STEP X



11)STEP XII

Connect the scythe-connector with hydraulic cylinder, in reverse order from STEP IX

12)STEP XIII

Fix the front cover to the main frame (Fig. 38).

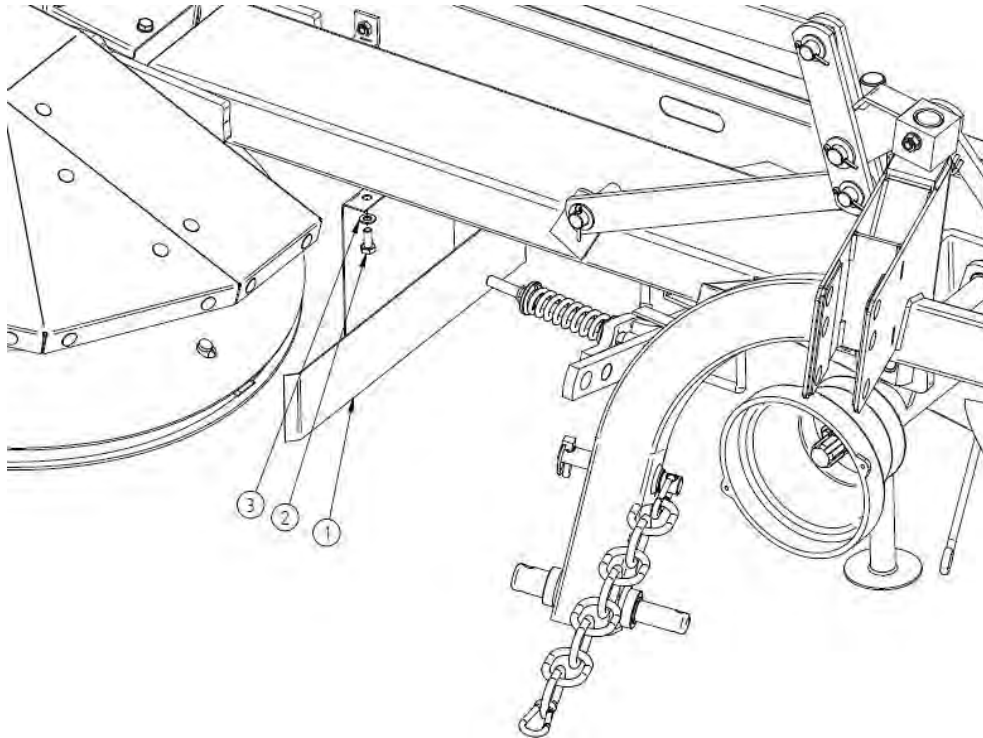

Item No.	Part No.	Name	Index
1	DM31201	Front Cover	
2	BM061025	Bolt- M6 x 1.0 x 25 GALV 8.8	
3	FW06	Flat Washer M10 galv.	

*GAVL – galvanized coating

Figure 38 Front cover assembly

No.	PART NO.	Name	Type	BDR210
				QUANTITY
1	CBM0812525	Carriage Bolt- M8 x 1.25	M8x25	71
	CBM0812520		M8x20	2
2	BM0812516	Bolt- M8 x 1.25	M8x16	6
	BM0812520		M8x20	2
3	LNMO8125	Self-locking Nut- M8 x 1.25 GALV	M8	81
4	FW08	Flat Washer- M8 GALV	M8	54
5	LFW10	Large Flat Washer- M10 GALV	M10	39

*GALV – galvanized coating

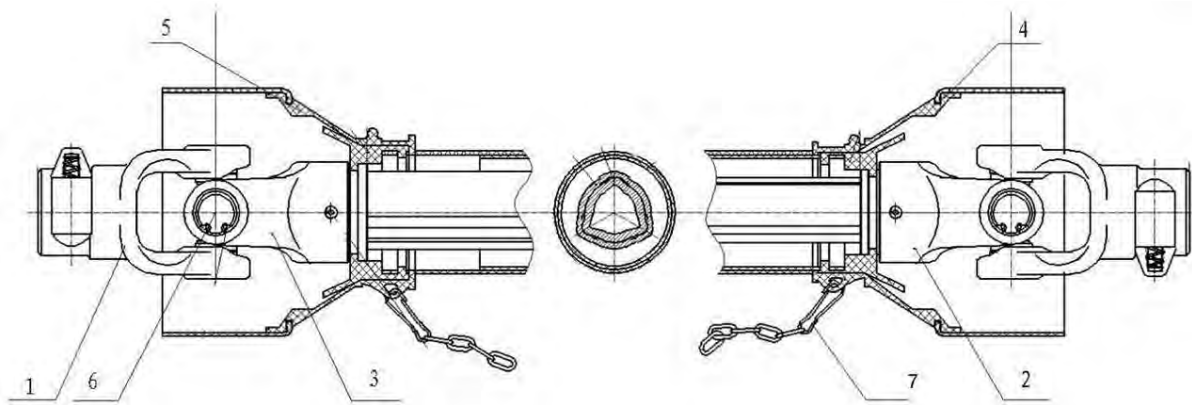

Position	Part Number	Description	Qty.
1		Yoke	2
2		Inner Yoke Complete	1
3		Outer Yoke Complete	1
4		Inner PTO Guard Complete	1
5		Outer PTO Guard Complete	1
6		Cross & Bearing	2
7		Safety Chain	2
8	DM30242	PTO Shaft Complete	1

WARRANTY

WARRANTY CARD

Factory no.	Model
Year of construction	KJ

Under warranty, the distributor undertakes to repair free of charge any physical defects revealed during the warranty period, which lasts for 12 months from the date of sale.

The manufacturer is exempt from any liability under the warranty in the case of:

- Mechanical damage of the machine, which occurred after it was delivered to the user.
- Improper use, maintenance, storage of the machine, in particular if not compliant with the User Manual.
- Execution of any repairs by unauthorized persons and without the consent of the distributor.
- Implementation of any design modifications without the consent of the manufacturer.

Warranty card is valid if it has the signature of the seller, and the date of sale confirmed by the official stamp of the dealer. It must not contain any deletions or corrections made by unauthorized persons. A duplicate of the warranty card may be issued upon written request of the user, who should present the valid proof of purchase.

In the case of ineligible call for the warranty service, any incurred costs shall be borne by the user. The user must report any complaints immediately after the damage, directly to the dealer or to the distributor.

The distributor provides warranty service within 14 days from the date, when the complaint has been received. The warranty period becomes extended for the time it took to repair the machine, calculated from the date of filing the complaint until the date of service repair, providing that the defect prevented the actual use of the machine.

The warranty does not cover any normal wear of parts such as: bearings, tarpaulins, fasteners, etc.

Date of sale: _____
(Day, month, year)

_____ *(Signature and stamp of a dealer)*

Records of warranty repairs

To be filled by the distributor

Date of complaint claim: _____

The scope of repair and parts used: _____

Date of complaint resolution: _____

Warranty period extended until: _____

(Dealer's signature and stamp)

Date of complaint claim: _____

The scope of repair and parts used: _____

Date of complaint resolution: _____

Warranty period extended until: _____

(Dealer's signature and stamp)

Date of complaint claim: _____

The scope of repair and parts used: _____

Date of complaint resolution: _____

Warranty period extended until: _____

(Dealer's signature and stamp)

Date of complaint claim: _____

The scope of repair and parts used: _____

Date of complaint resolution: _____

Warranty period extended until: _____

(Dealer's signature and stamp)

Warranty form



WARRANTY FORM NO.

Full name:

Address:

Post code:

City:

Telephone No:

Email address:

Reason for claim:

Persons Name:

Name of the dealer:

Proof of purchase- Invoice no.Date:20.....

Description of damages:

.....
.....
.....
.....
.....
.....
.....
.....
.....
.....
.....

The date of complaint resolution:

Means and time of the complaint resolution:

.....
.....

Date the fault occurred or was discovered:20.....

.....
Date, Full name

Assembly Instructions BDM 210



Note: This supplement is only an addition to the User Manual that the operator is required to read before using the machine!

Step 1. Prepare the necessary tools: drill/driver, PH2 drill bit, hammer, pliers, Philips screwdriver, chisel, combination wrenches:

- M13 – 2 pcs.
- M17- 2 pcs.
- M19- 2 pcs.
- M24- 1 pc.
- M30- 1 pc.



Step 2. Remove the 20 screws on the top with the PH2 bit



Step 3. After removing the boards, remove the top cover, PTO shaft, guard rails, hydraulic kit, support foot and the suspension frame from the box





Step 4. Remove the flat drawbar from the hydraulic set, to do this, take out the cotter and pivot pin



Step 5. Install the flat drawbar to the mower according to the diagram beside and secure it with a linchpin on both sides. To do this, it is necessary to lift the mower frame. Remember to put a flat bar with an adjustment hole in the place marked "A"

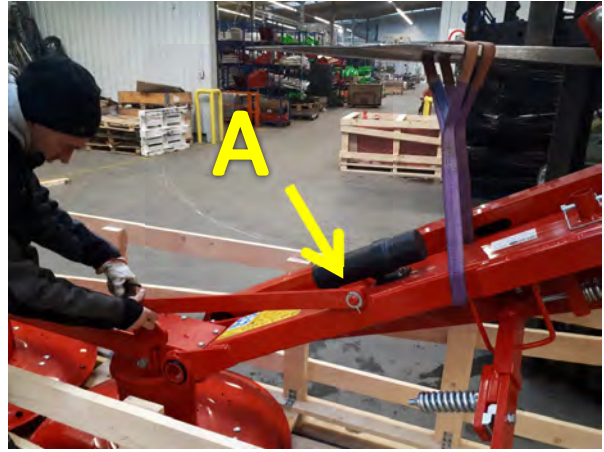

Step 6. Raise the mower with a device/machine with a lifting capacity greater than the mower weight, which is indicated on the data sticker on the mower. For this purpose, use transport belts, slings, ropes or chains, bearing in mind the machine's center of gravity



Step 7. Install the support foot, then raise the mower frame again, unlock the previously mounted flat bar and lower the machine



Step 8. Unscrew the screw "B" and loosen the nut "C"

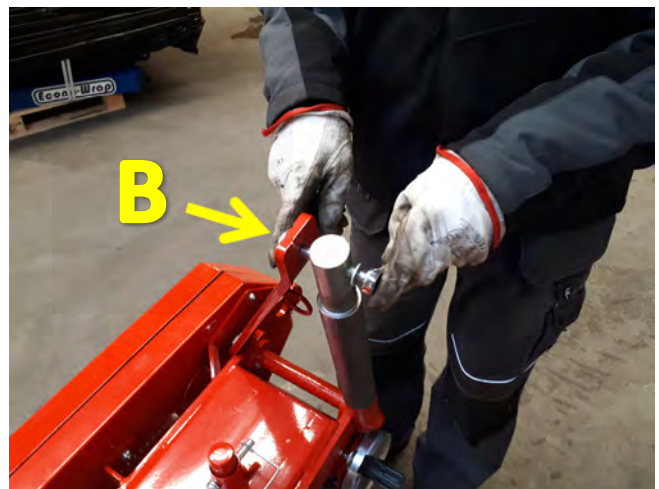



Step 9. Fold back the "D" bar and put on the 3 point hitch



Step 10. Put the head from the hydraulic kit on the pivot axle and tighten the bar, axle and head firmly with a bolt, as shown beside



Step 11. Tighten the nut "C" and secure it with the metal plate using a hammer and chisel

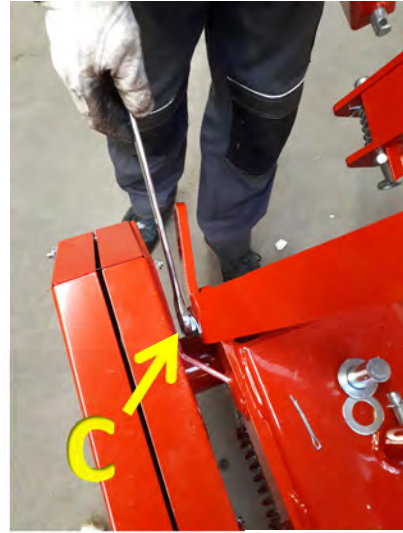

Step 12. On the hydraulic cylinder, put a pivot pin through the hole at the headstock, secure with a washer and cotter pin. Do the same on both ends of the cylinder





Step 13. Place the break-back unit on the pin in the frame and secure with a cotter pin



Step 14. Using stands, spread out the cover on a secured surface



Step 15. Unpack the bag with bolts, unfold the bent reinforcements and bolt them on to the cover. Make sure that the marked "E" holes are in the correct direction, ie outside in both reinforcements. Then bolt on the rear cover and the pipe barriers. In addition, detailed instructions for assembling the cover are included in the User Manual that comes with each mower

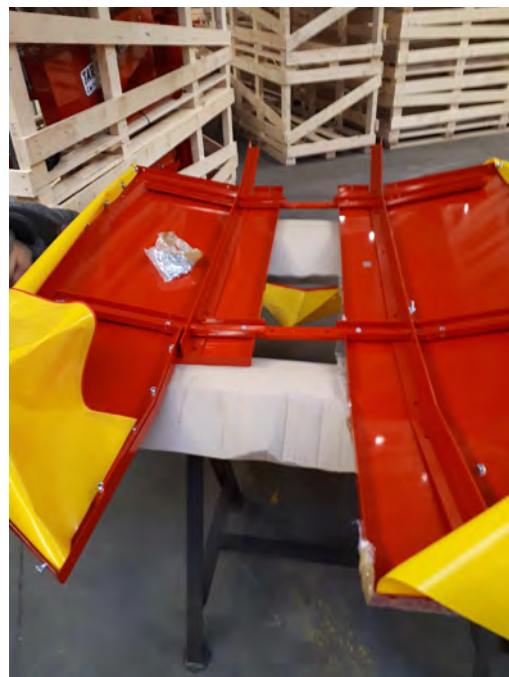
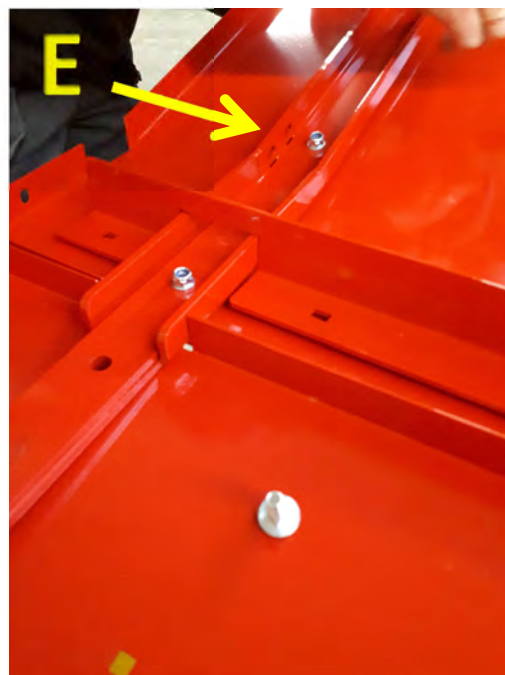



Step 16. Remove the bolts "F" and lift the tie rod "G" up



Step 17. Remove the 6 bolts from the mower frame to bolt on the cover



Step 18. Place the cover on the machine, fit it to the empty bolt holes from step 17, and tighten with the same bolts. Then tighten the previously unscrewed flat bar from step 16



Step 19. Assemble the bottom cover, attach the PTO shaft to the machine, put on the rubber cover and secure with a plastic clamp band



Step 20. Guide the lock pin string as shown in the diagram



Step 21. Guide the cylinder string as shown in the diagram



Step 22. To tighten the v-belts, loosen the "H" nut and tighten the "I" nut. Control the tension of the belts through the inspection hole located inside the internal cover of the belts, tighten the nut "I" if necessary. After obtaining the appropriate tension, secure the "I" nut and counter the "H" nut tightly against it

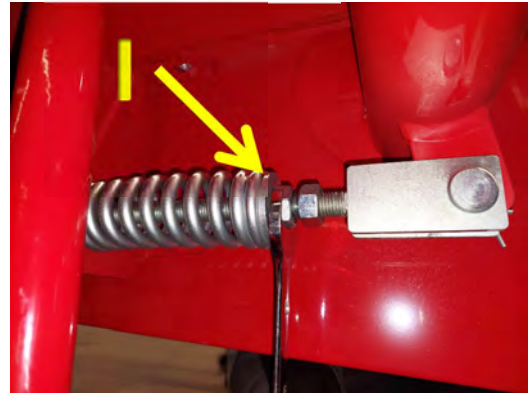
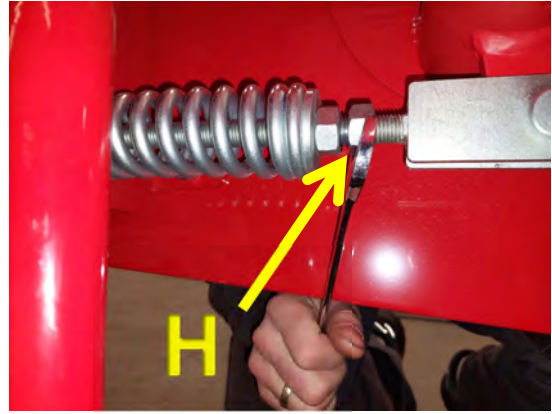



401 Jeffreys Road
Rocky Mount, NC 27804
www.tarrivermfg.com

Tel: 252-822-7140
Fax: 252-787-5855
Sales@tarrivermfg.com